

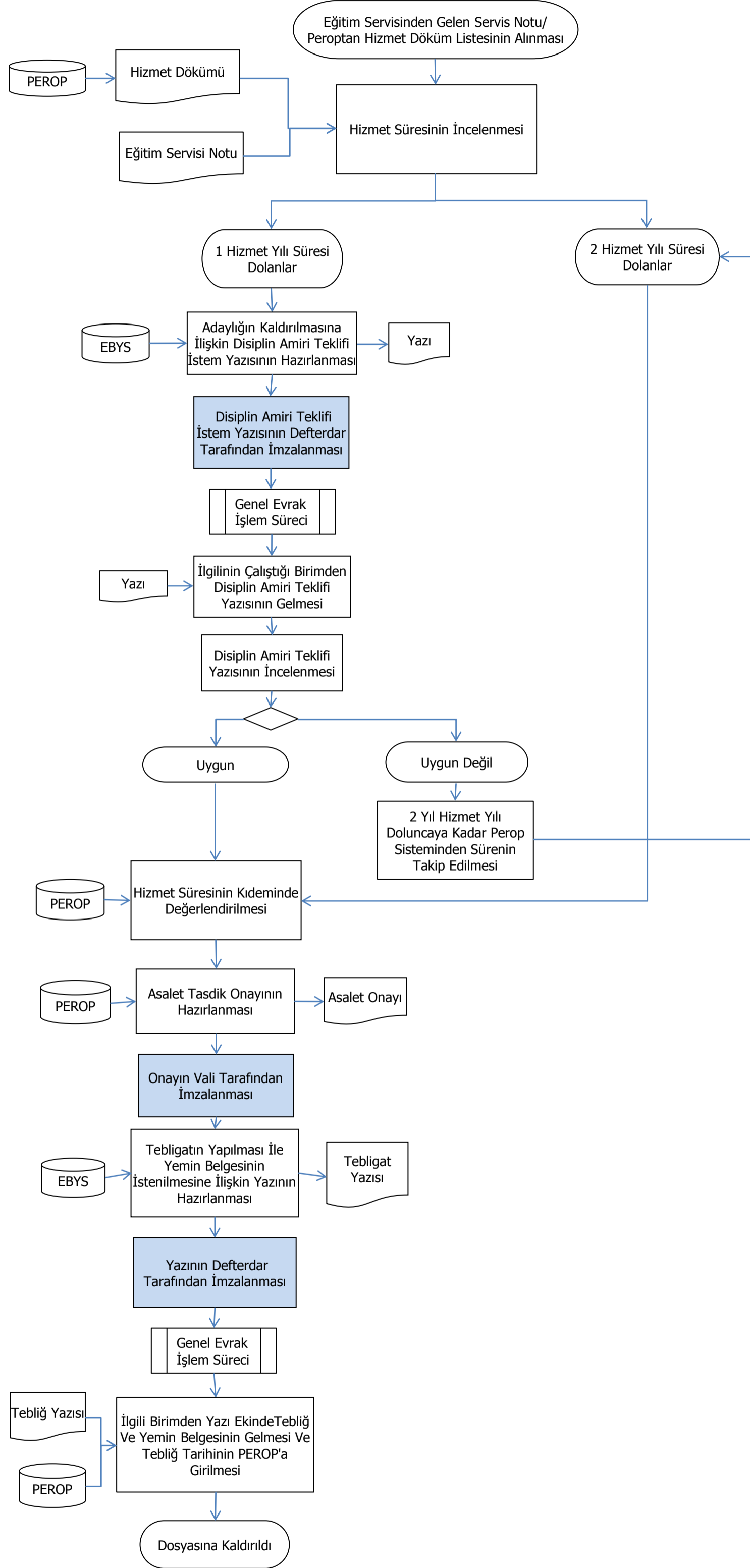

BURDUR Defterdarlığı Personel Müdürlüğü

Adaylığın Kaldırılması İşlem Süreci



Hazırlayan:	Onaylayan:



BURDUR Defterdarlığı Personel Müdürlüğü

Açıktan Atama İşlem Süreci

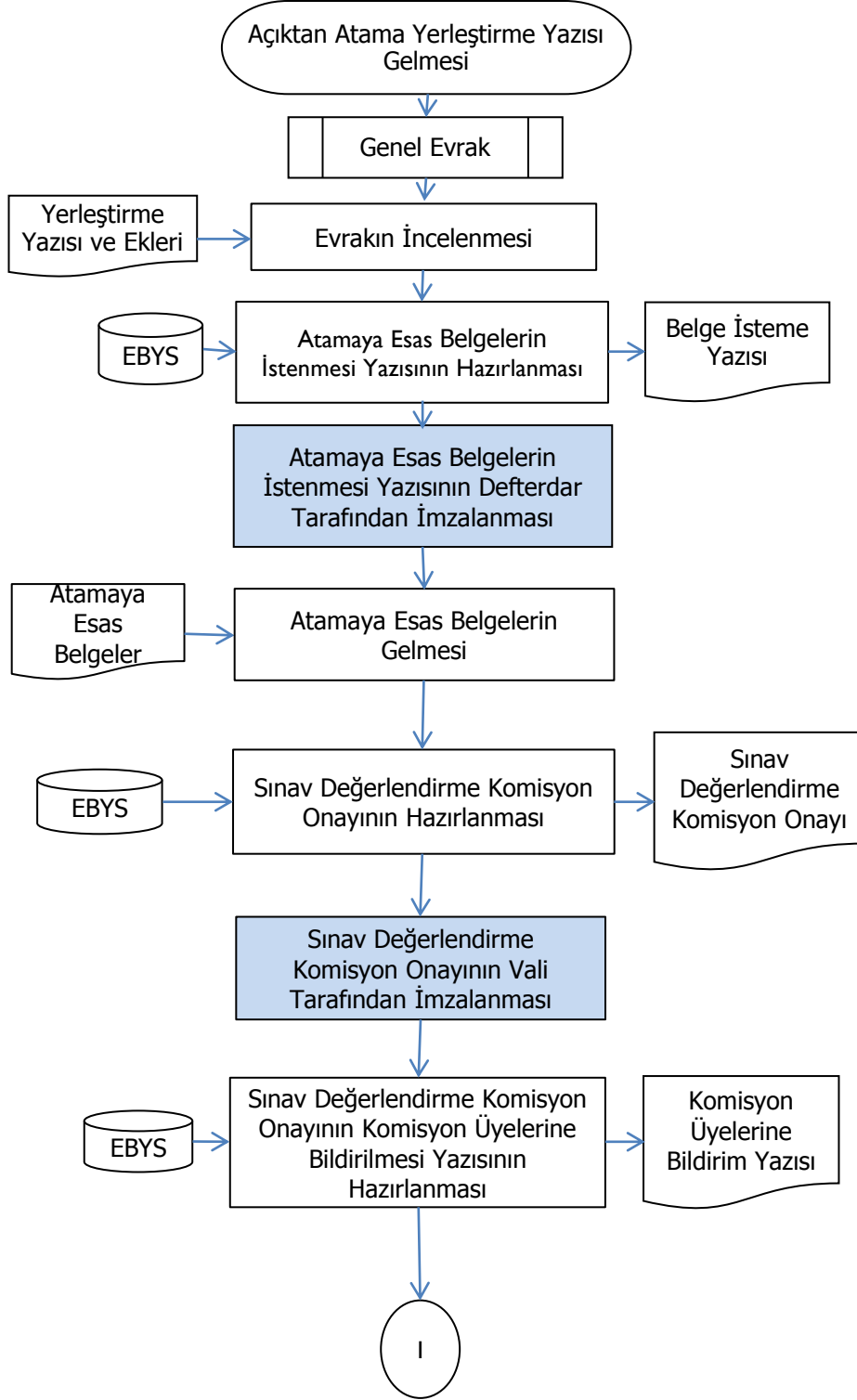

Hazırlayan:	Onaylayan:

Açıktan Atama İşlem Süreci

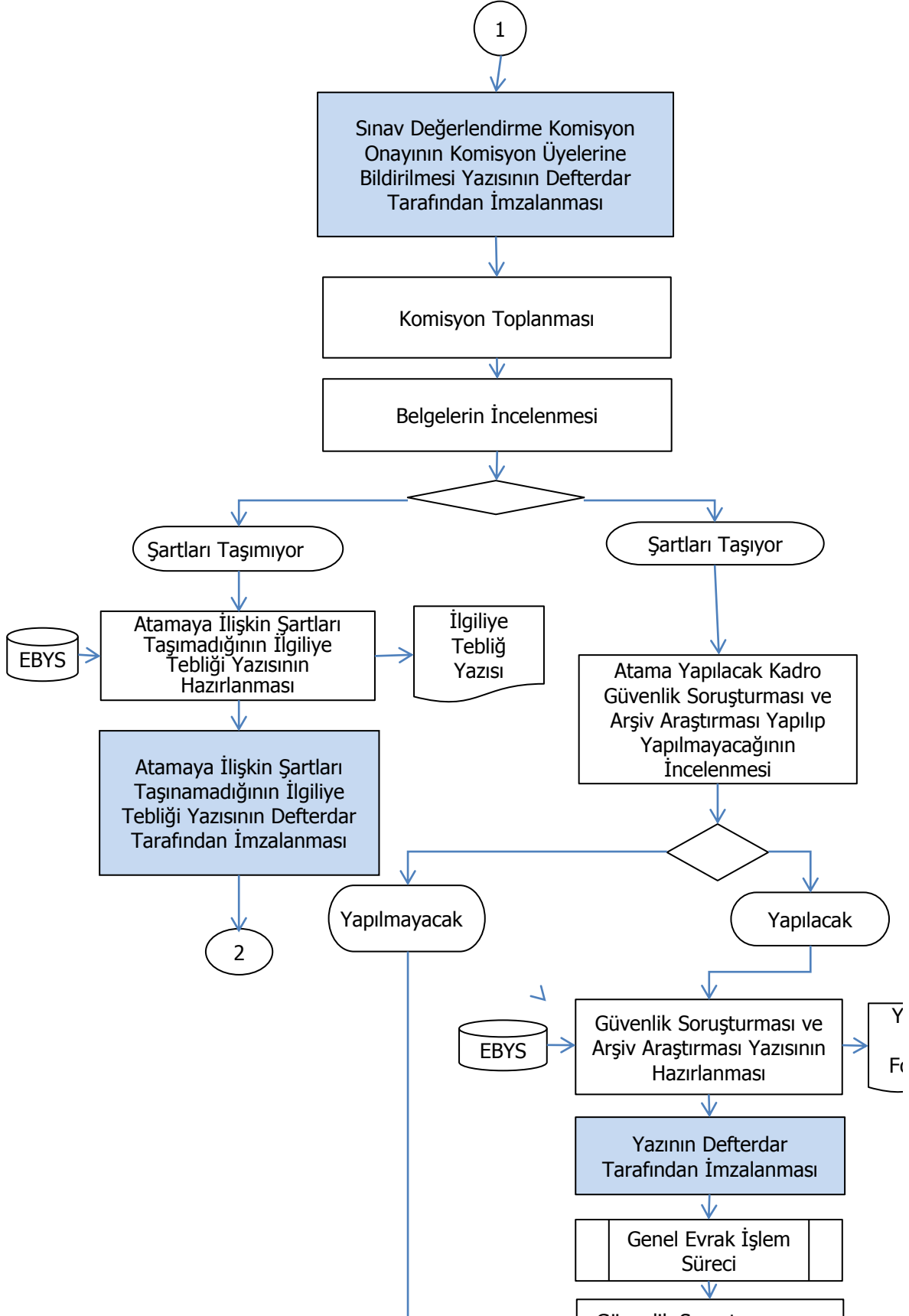

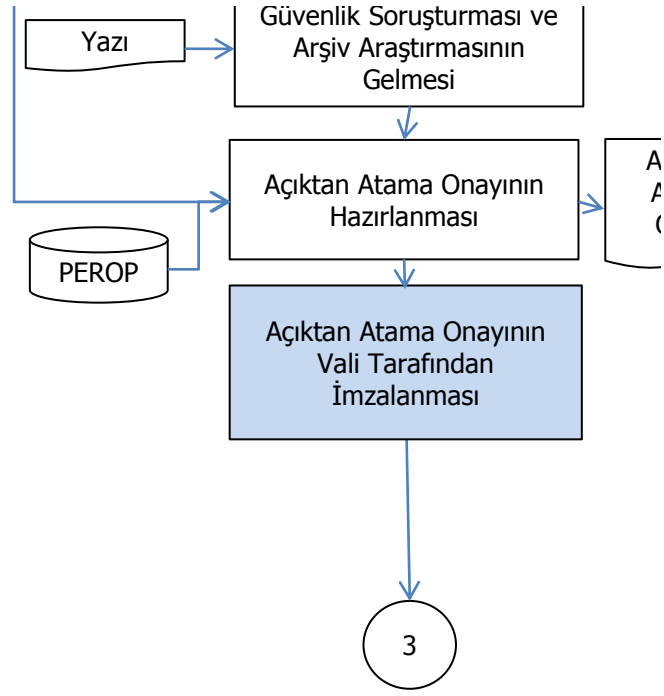

Hazırlayan:	Onaylayan:

'azı ve
Eki
ormlar

çıktan
Atama
Onayı

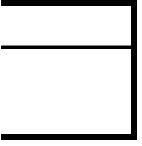



BURDUR Defterdarlığı Personel Müdürlüğü

Açıktan Atama İşlem Süreci

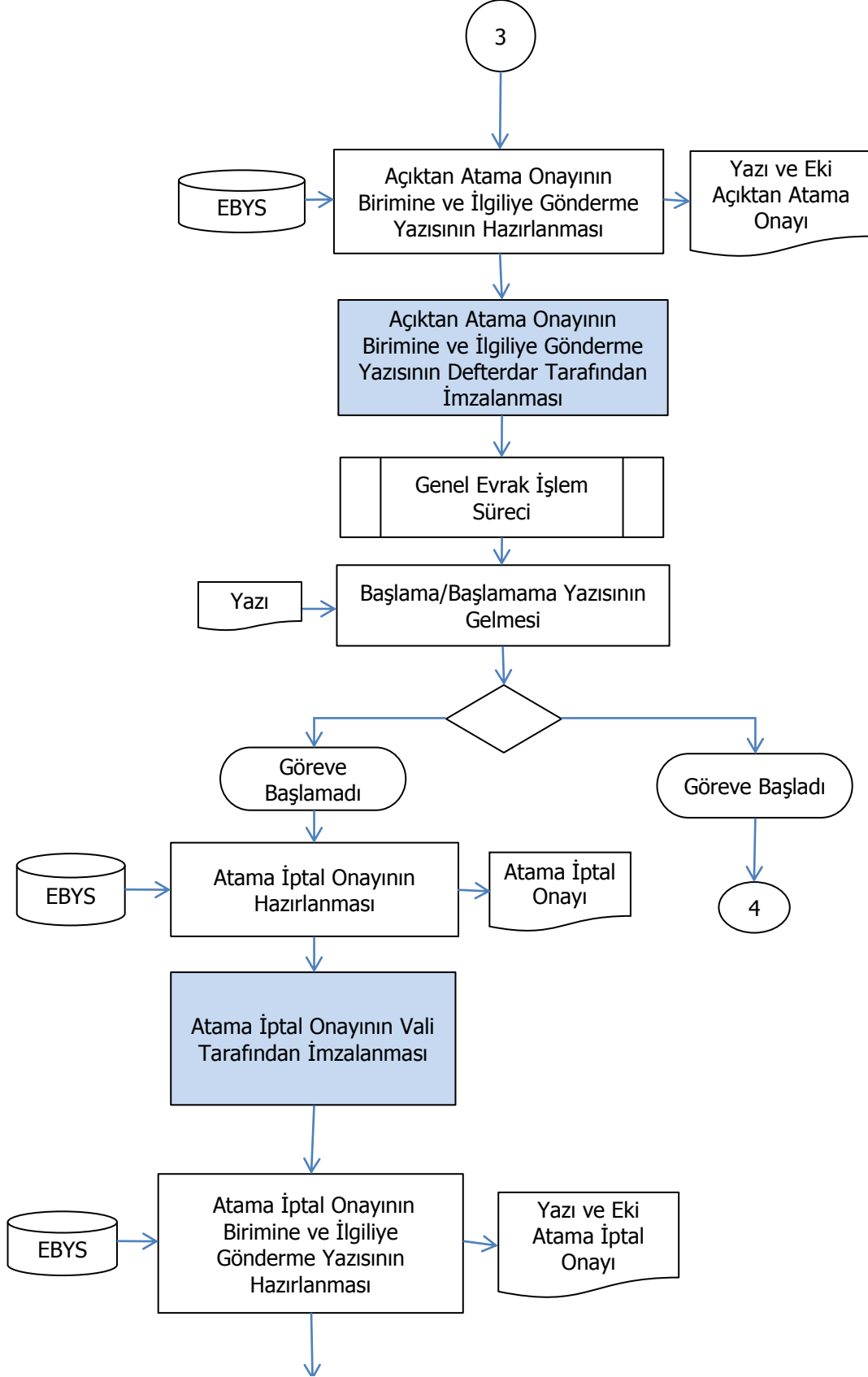

Atama İptal Onayının
Birimine ve İlgiliye
Gönderme Yazısının
Defterdar Tarafından
İmzalanması

5

Hazırlayan:	Onaylayan:

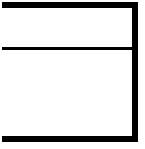

BURDUR Defterdarlığı Personel Müdürlüğü Açıktan Atama İşlem Süreci

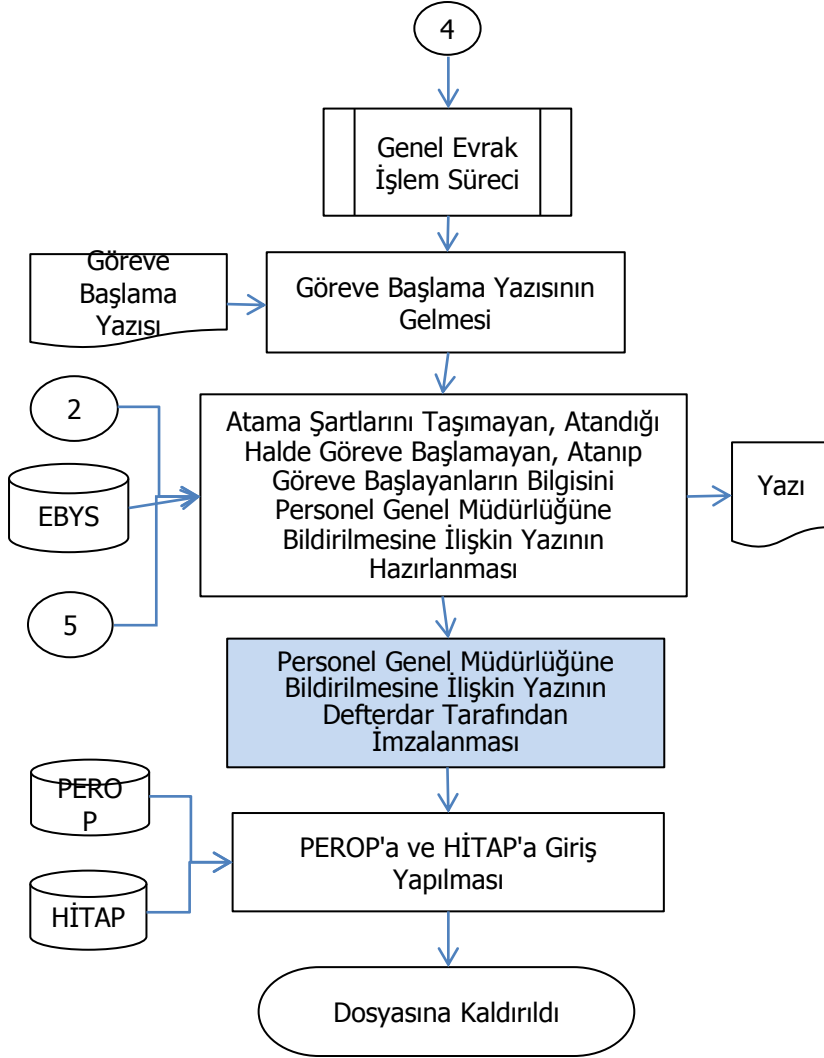

--	--

BURDUR Defterdarlığı Personel Müdürlüğü

2828, 3713 ve 4046 Sayılı Kanunlar Kapsamında Yapılan Atama İşlem Süreci

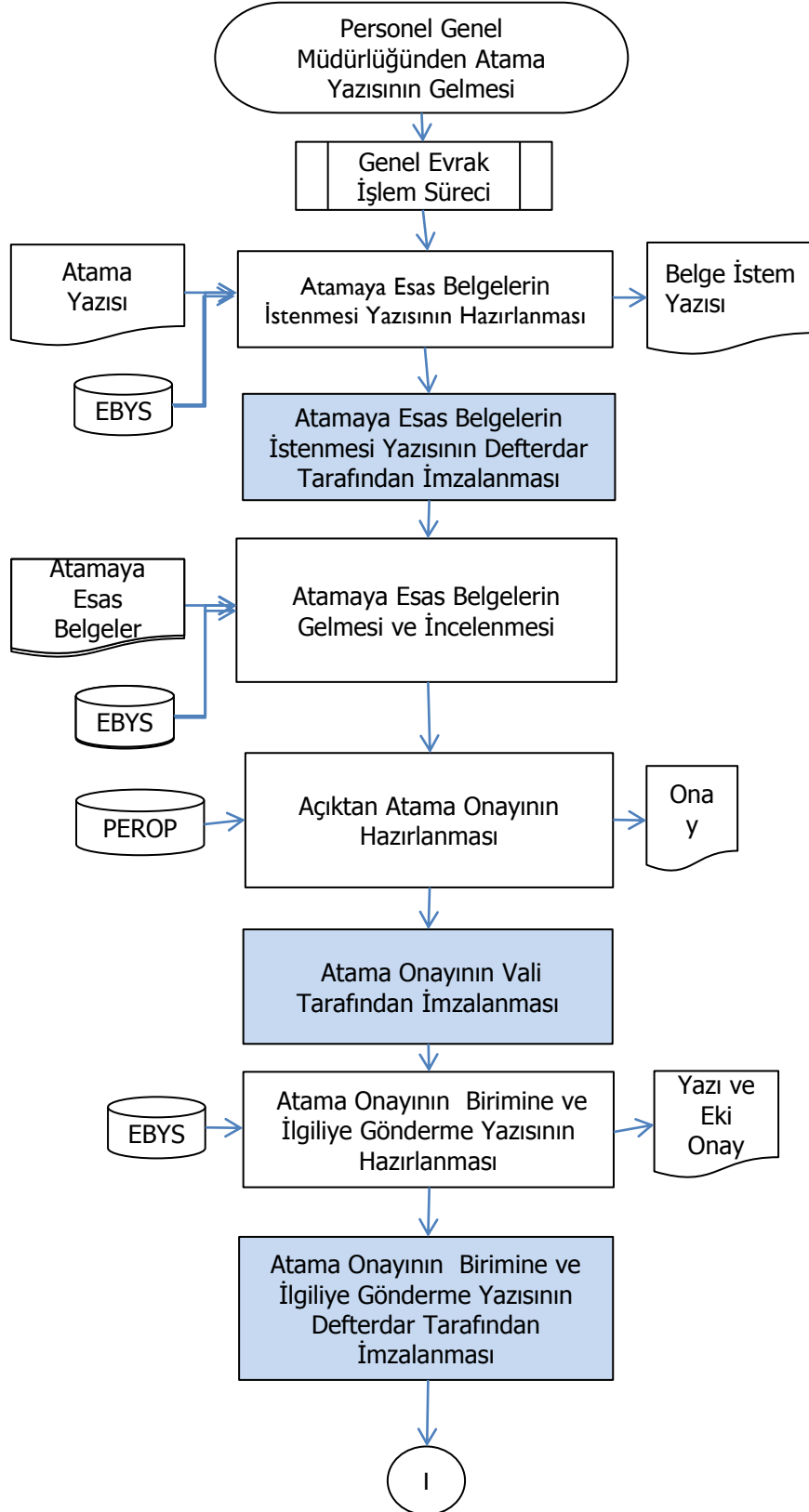

Hazırlayan:

Onaylayan:

--

--



BURDUR Defterdarlığı

Personel Müdürlüğü

2828, 3713 ve 4046 Sayılı Kanunlar Kapsamında Yapılan Atama İşlem Süreci

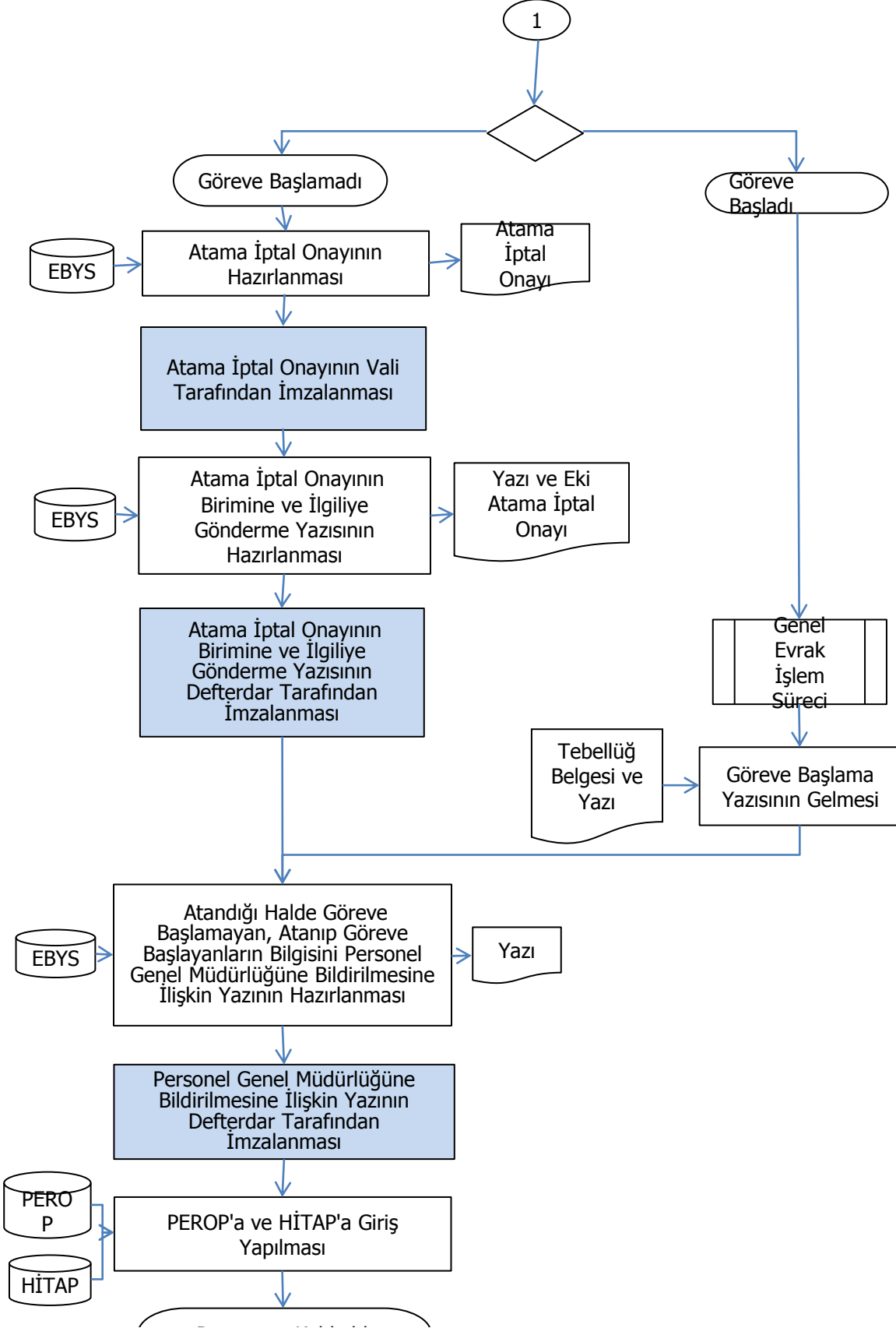

Dosyasına Kaldırıldı

Hazırlayan:	Onaylayan:

|



BURDUR Defterdarlığı Personel Müdürlüğü

Aylıksız İzin İşlemleri İşlem Süreci

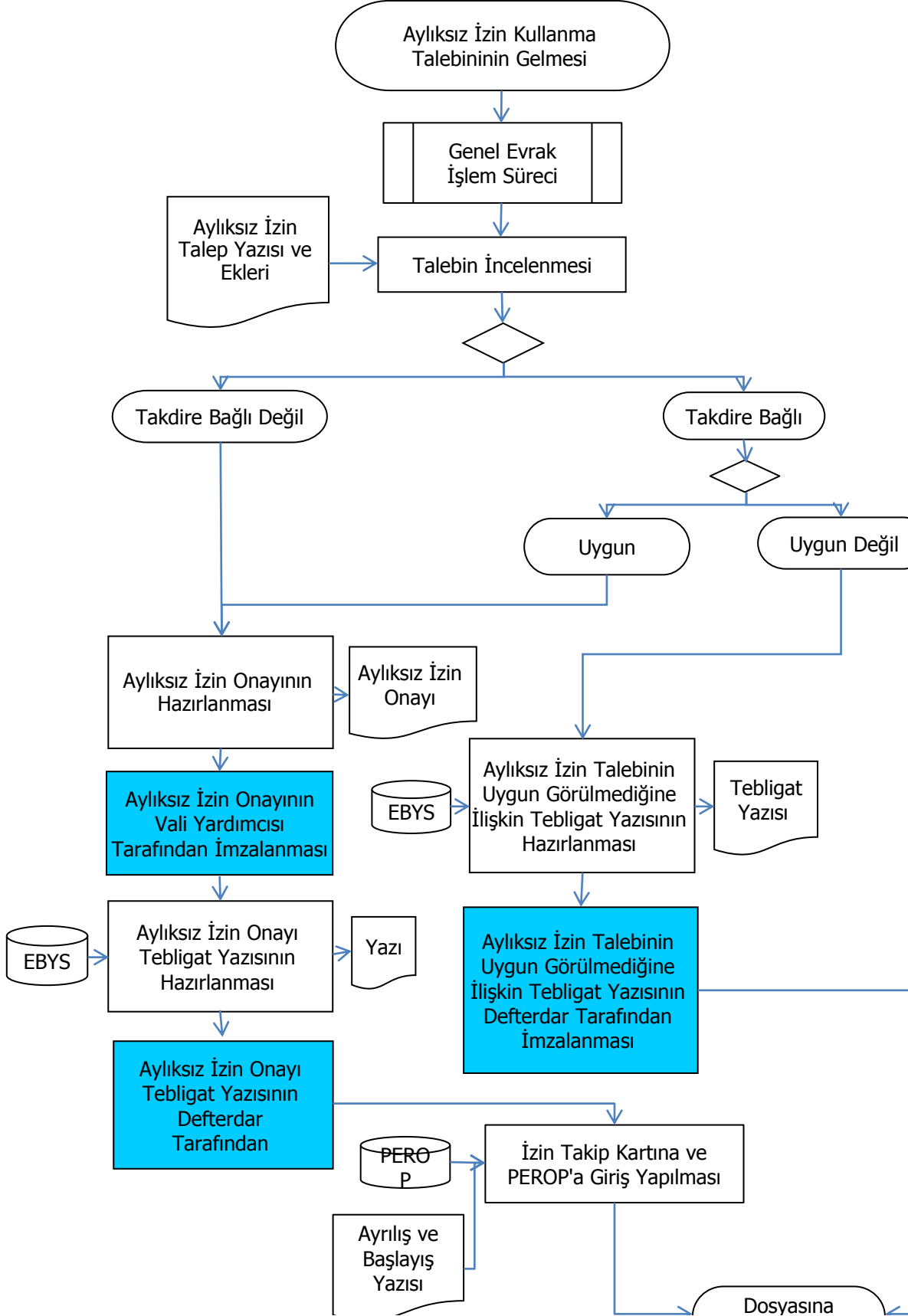

—

→ Kaldırıldı ←

Hazırlayan:	Onaylayan:

)

]

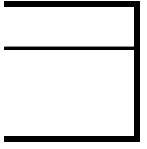

BURDUR Defterdarlığı Personel Müdürlüğü

Görevde Yükselme Ve Unvan Değişikliği İşlem Süreci

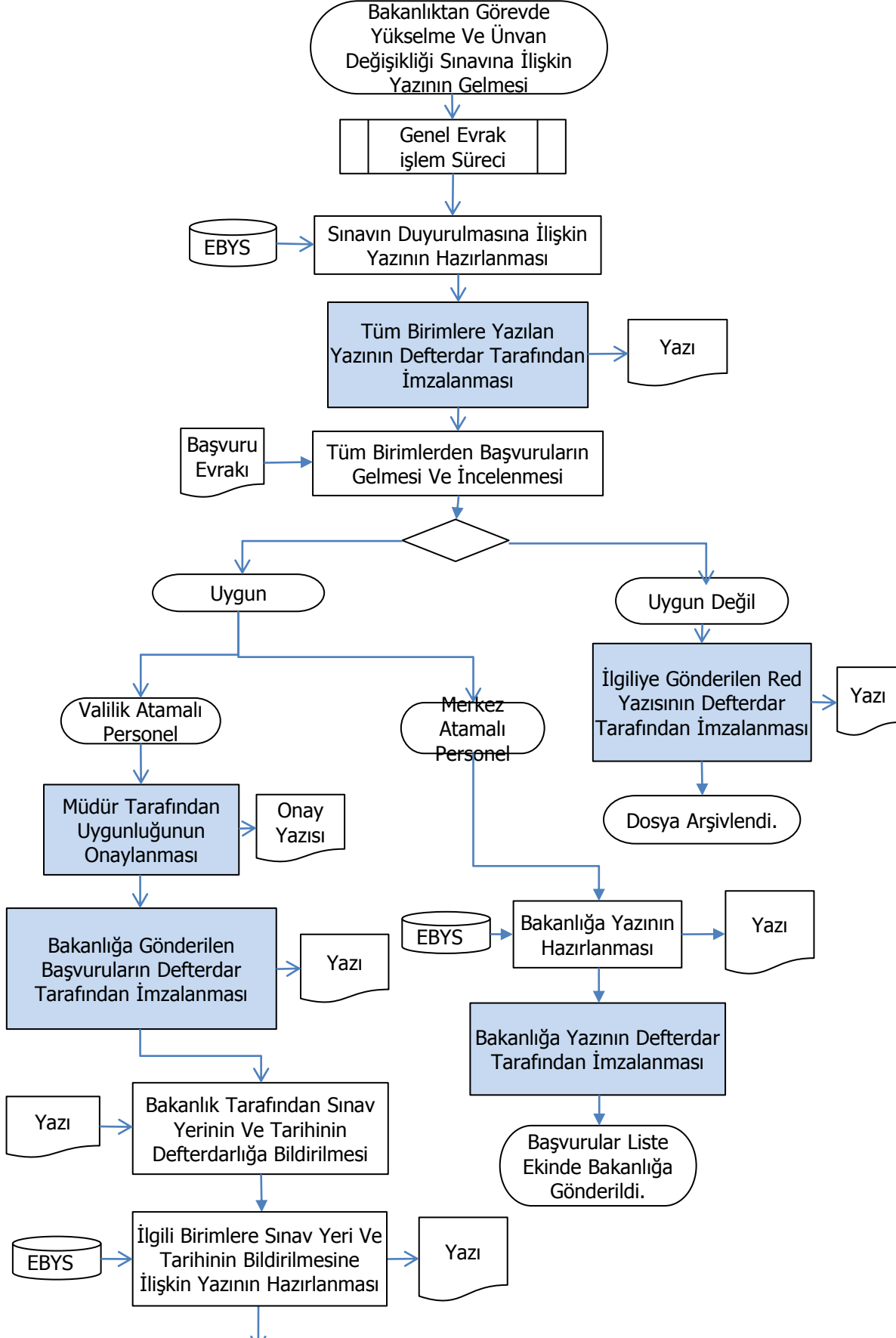

1

Hazırlayan:	Onaylayan:



BURDUR Defterdarlığı Personel Müdürlüğü

Görevde Yükselme Ve Unvan Değişikliği İşlem Süreci

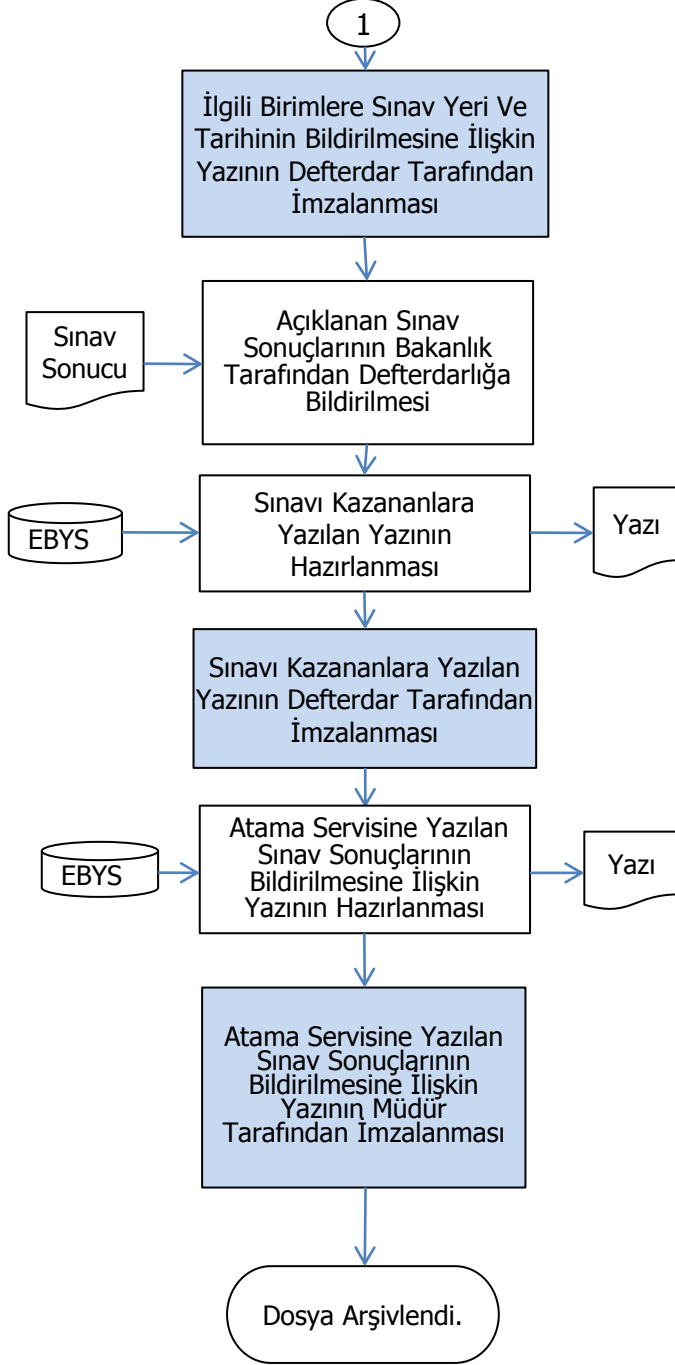

Hazırlayan:	Onaylayan:

Hizmet Değerlendirme İşlem Süreci

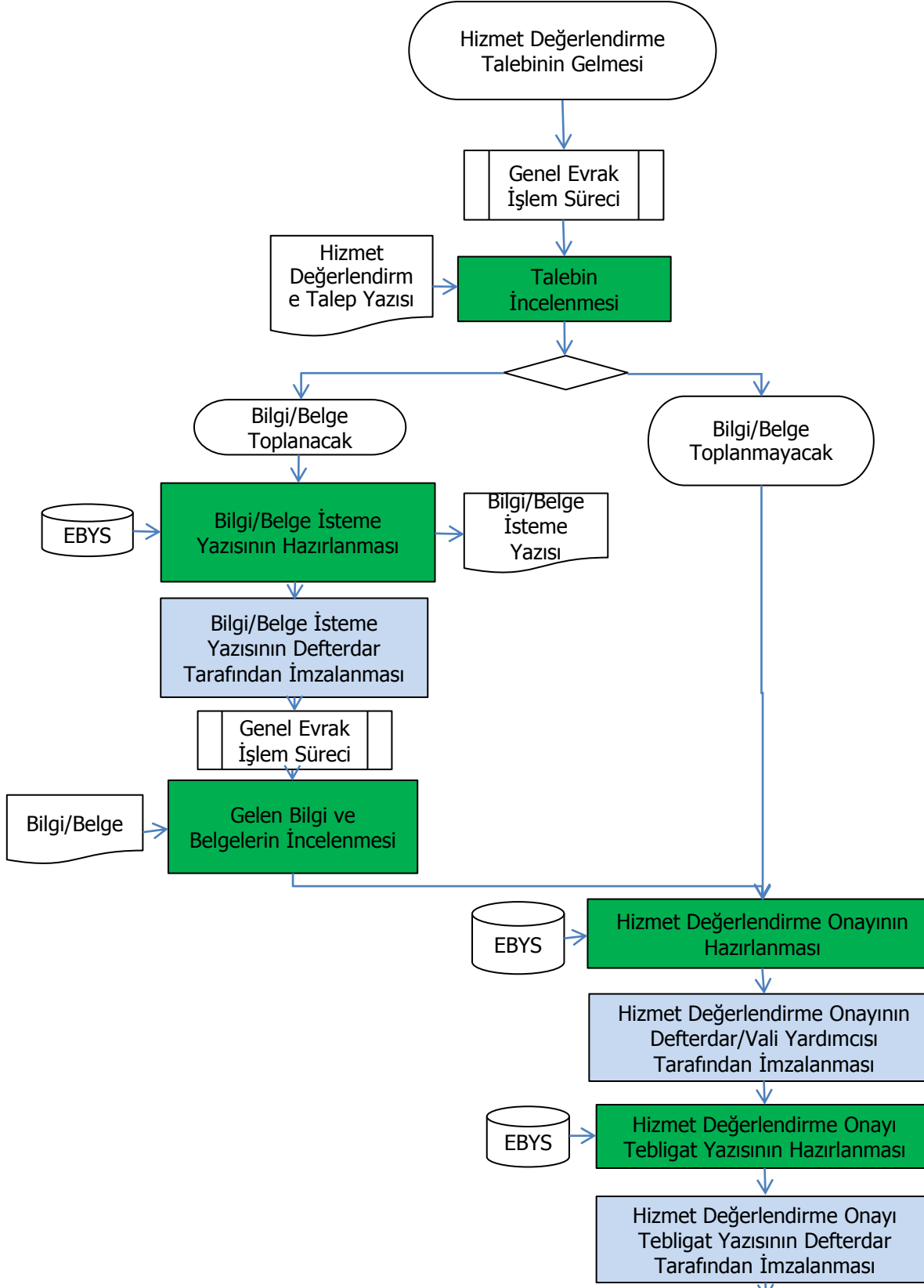

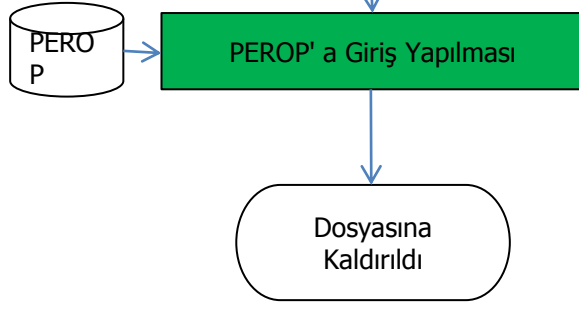

Hazırlayan:	Onaylayan:



I

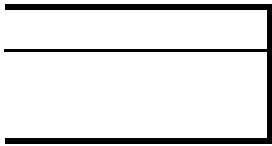



Naklen Atama İşlem Süreci

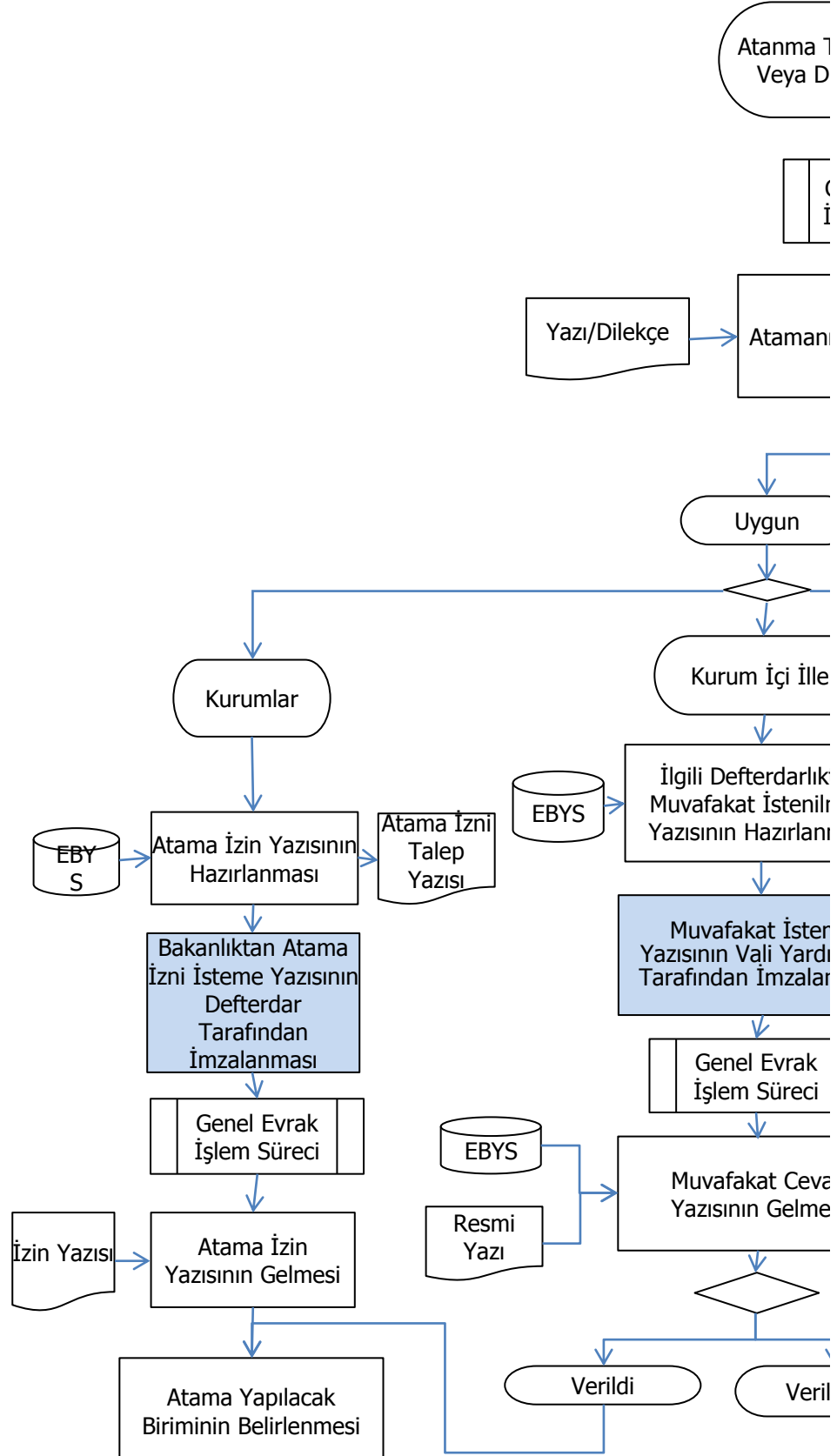

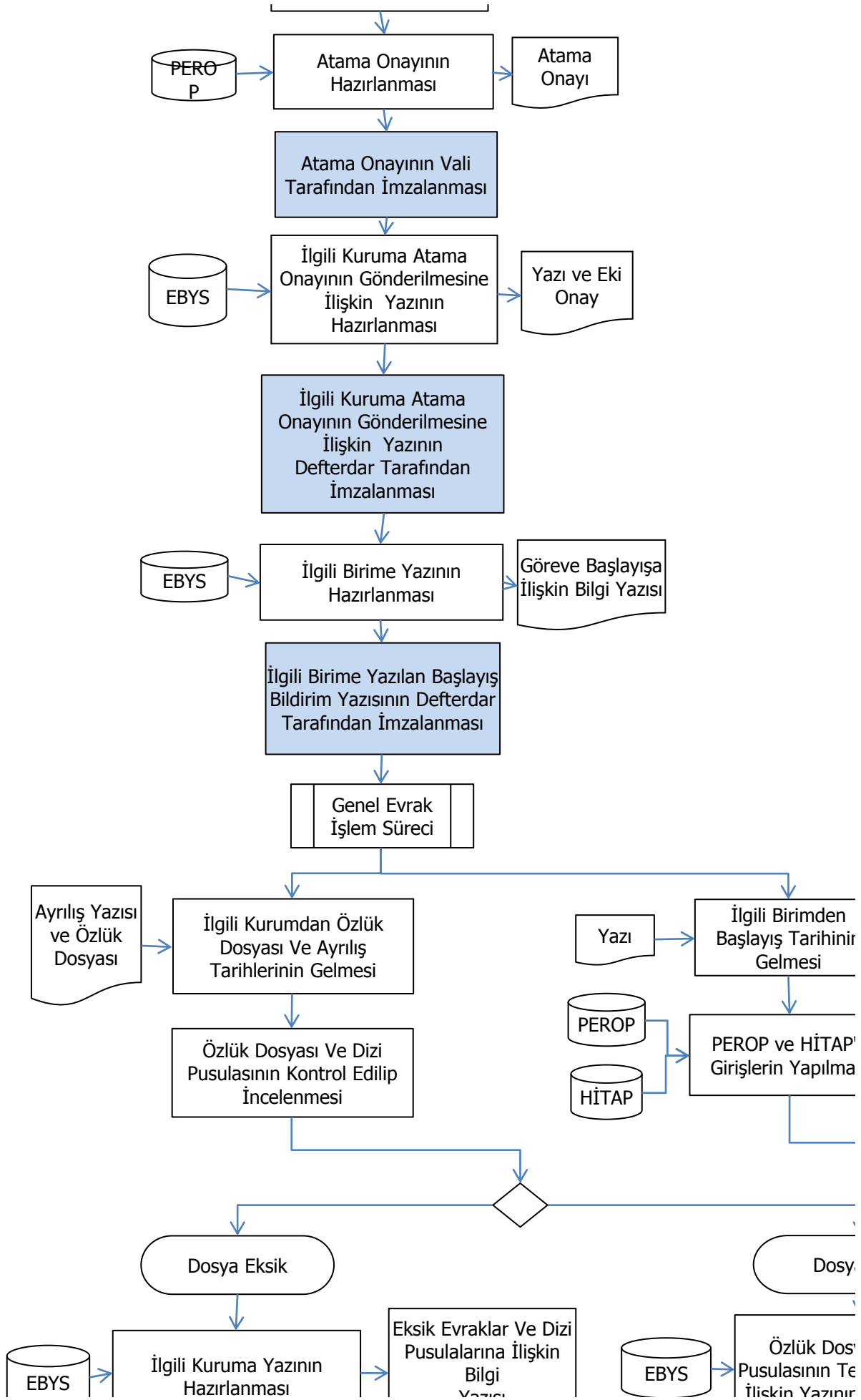

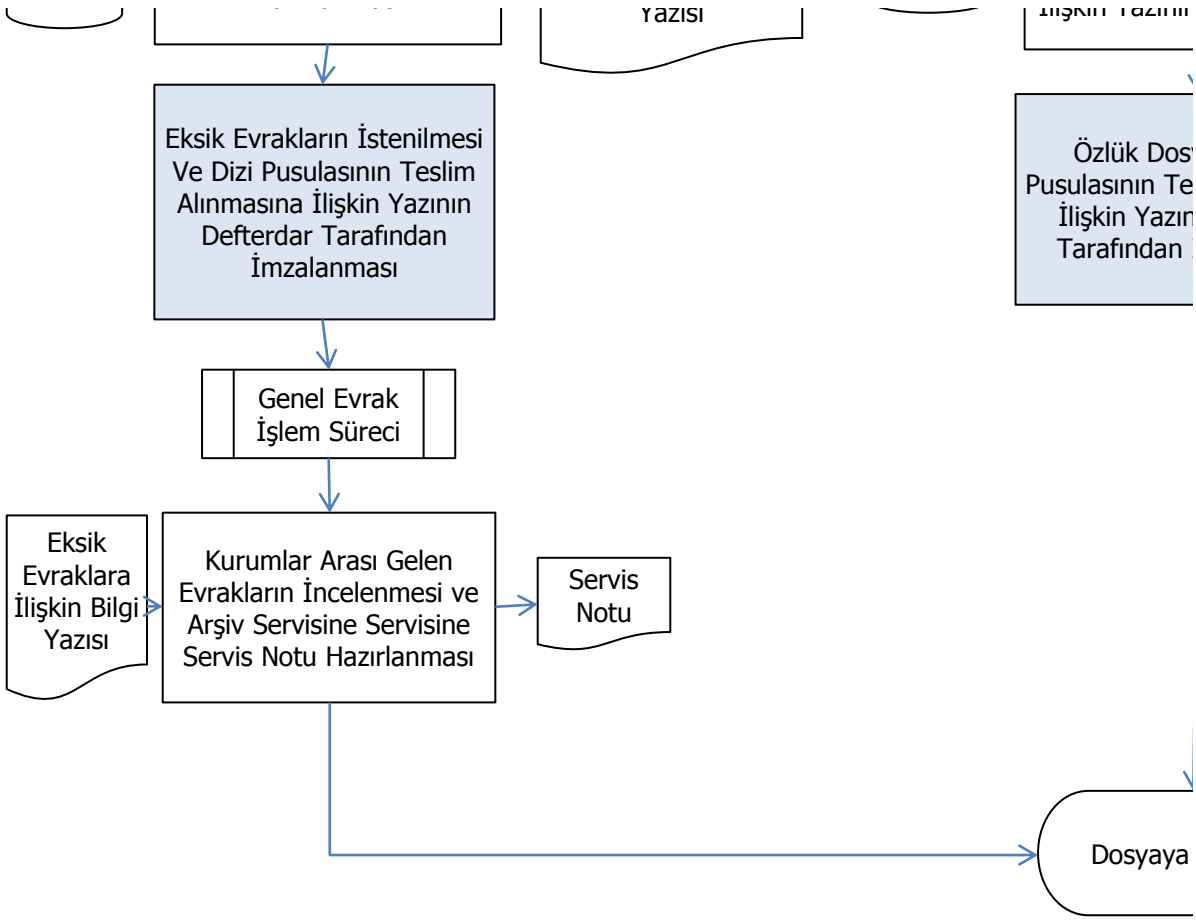

Hazırlayan:

BURDUR Defterdarlığı

Personel Müdürlüğü

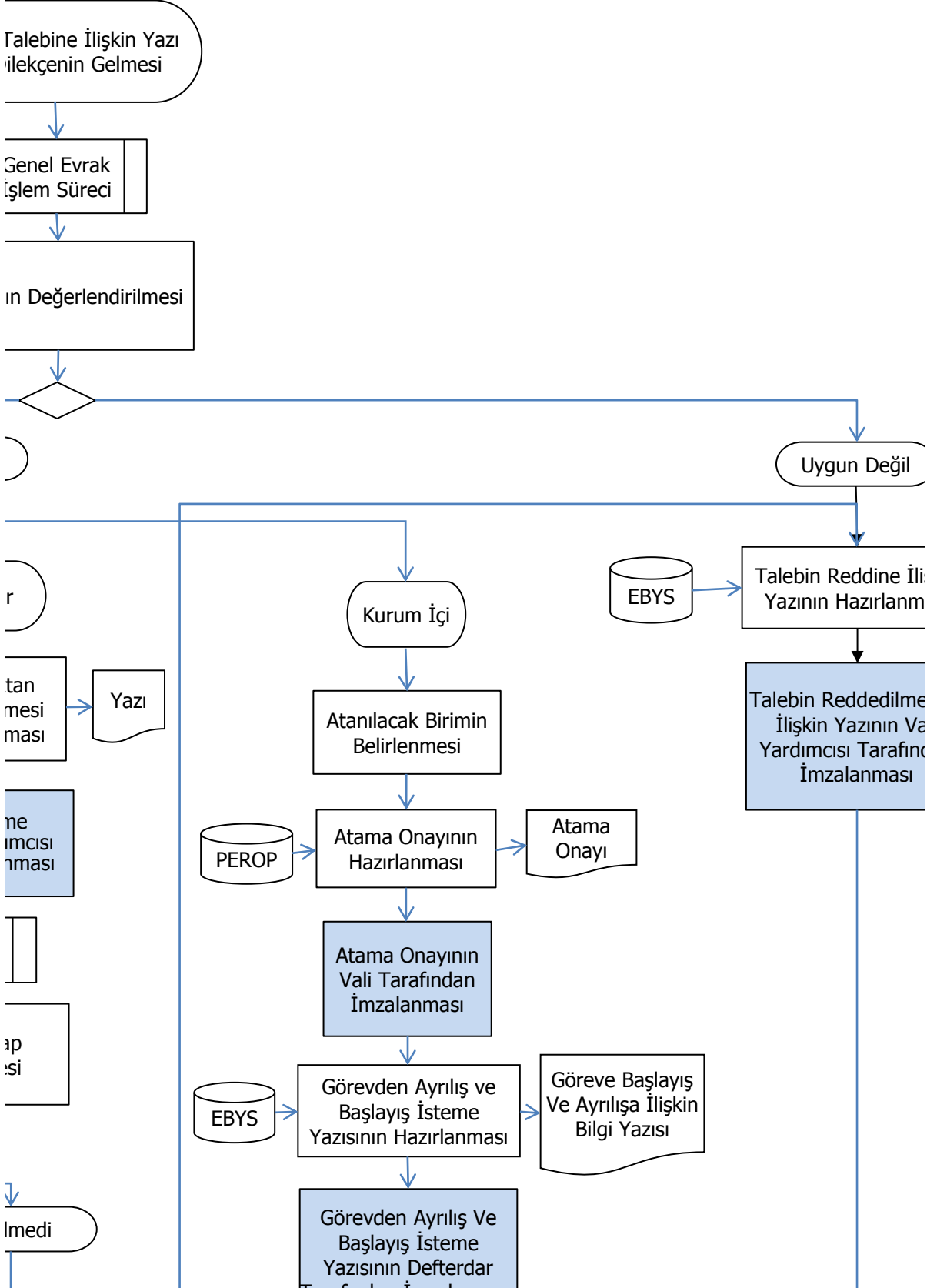

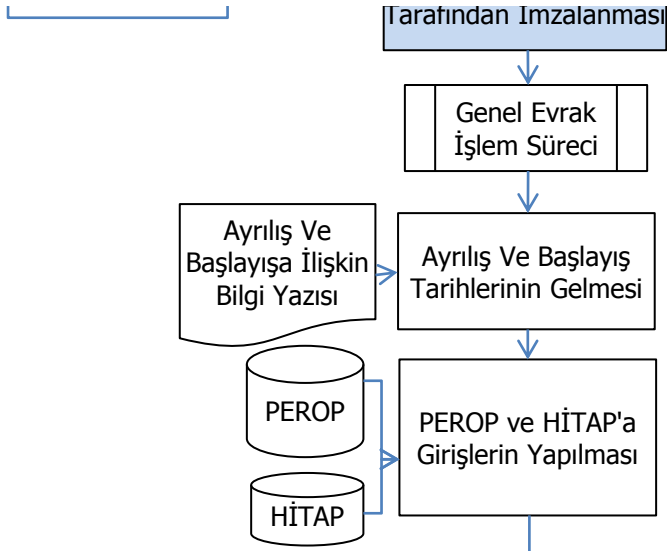

n

'a
İSİ

↓
a Tam

↓
yayı ve Dizi
teslim Alındığına
Hazırlanması

Özlük Dosyası ve Dizi
Pusulmasının Teslim
Alındığına İlişkin Yazı

İmzalanması

Yasası ve Dizi
İslim Alındığına
nın Defterdar
İmzalanması

Kaldırıldı

Onaylayan:

)

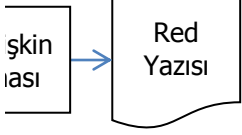

esine
ali
dan

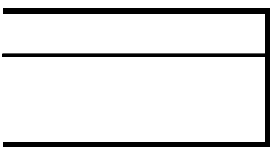



BURDUR Defterdarlığı Personel Müdürlüğü

Mazeret İzni İşlemleri Süreci

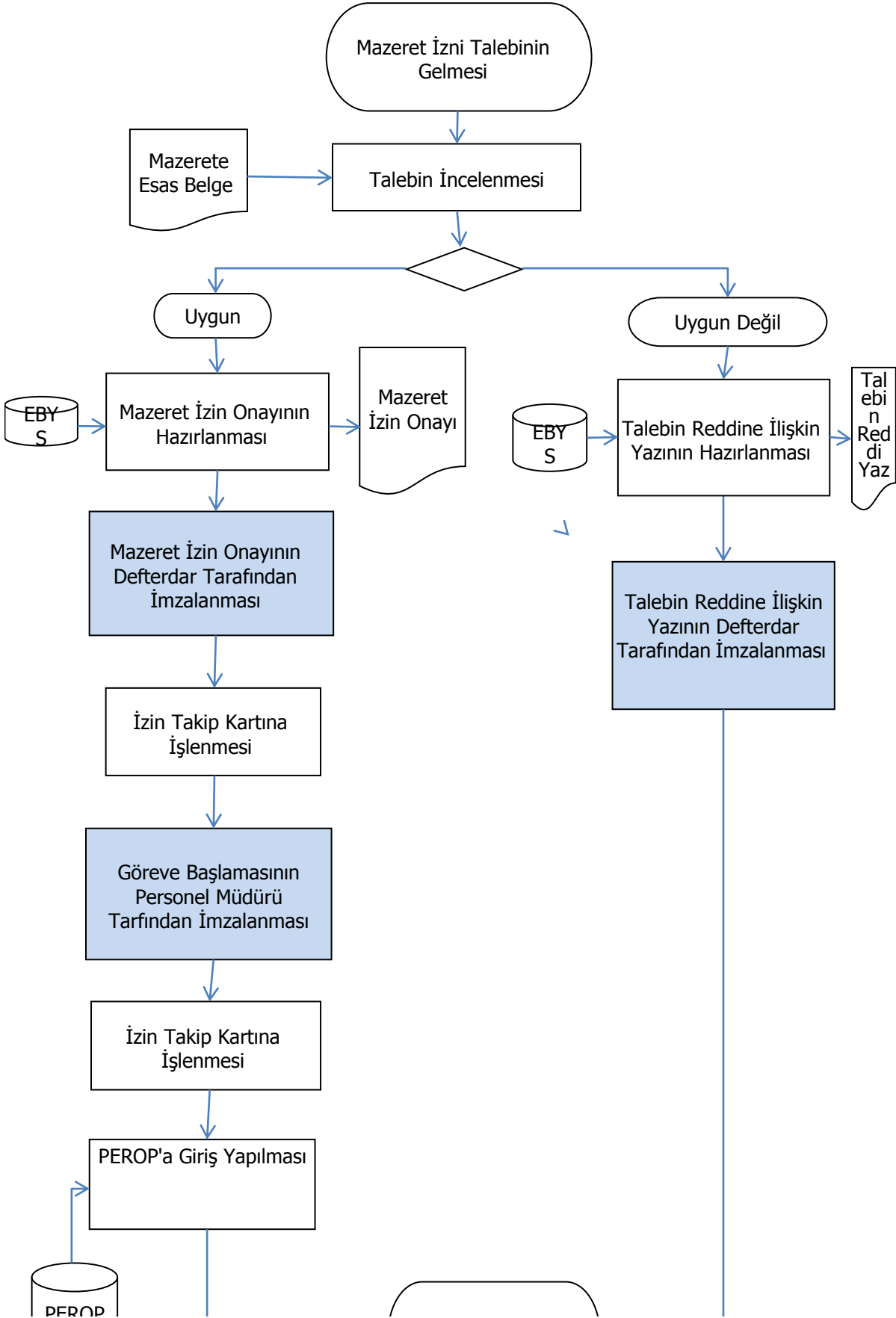

FLRUP

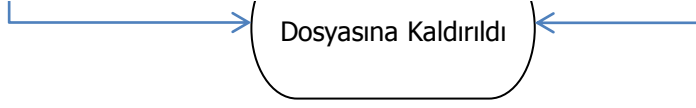

Hazırlayan:	Onaylayan:



BURDUR Defterdarlığı Personel Müdürlüğü

Bakanlık Atamalı Personelin Emeklilik,Çekilme Ve Aylıksız İzin Taleplerine İlişkin İşlem Süreci

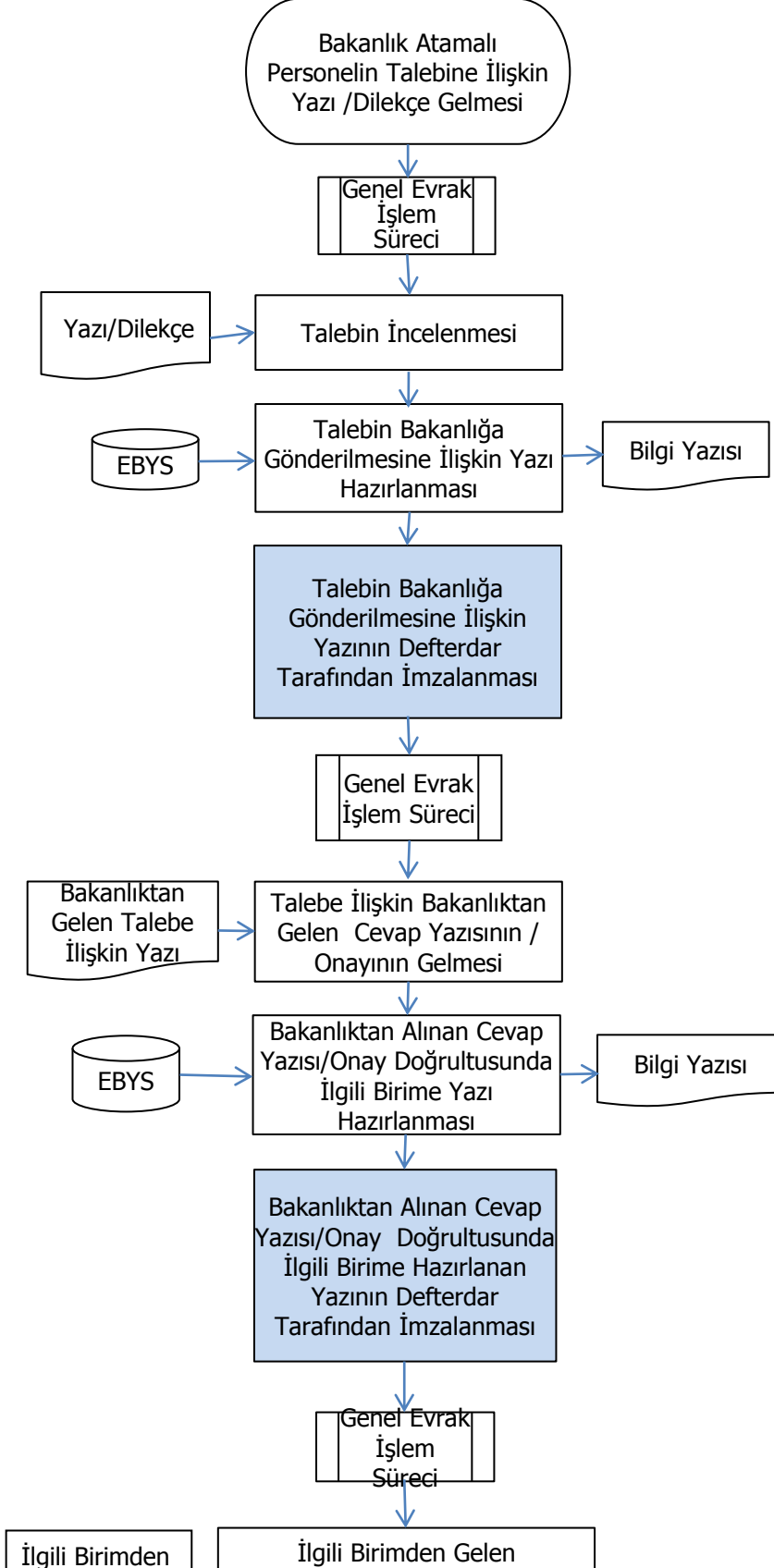

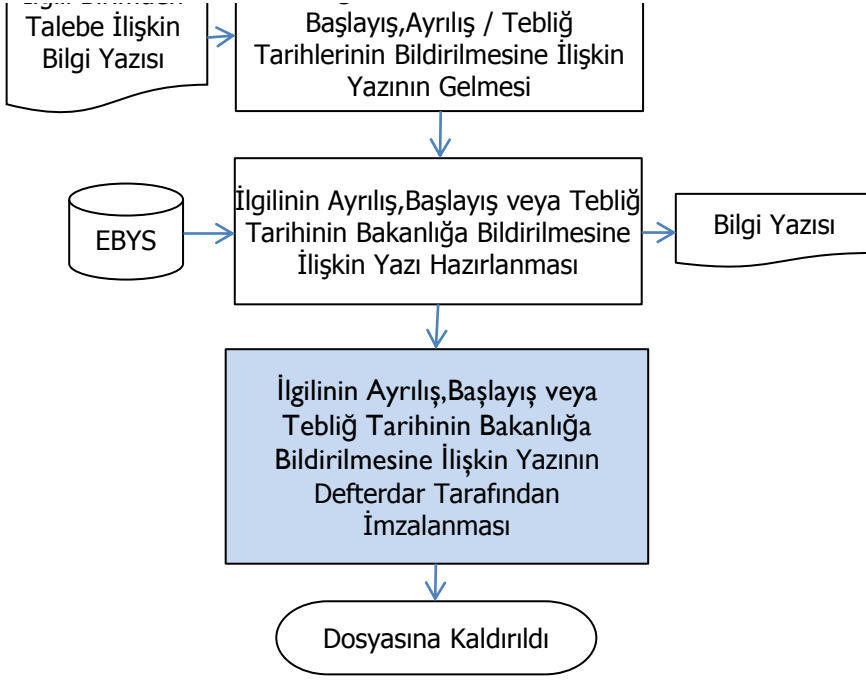

Hazırlayan:	Onaylayan:



BURDUR Defterdarlığı Personel Müdürlüğü

Bakanlık Atamalı Personelin Görevden Ayrılış İşlem Süreci

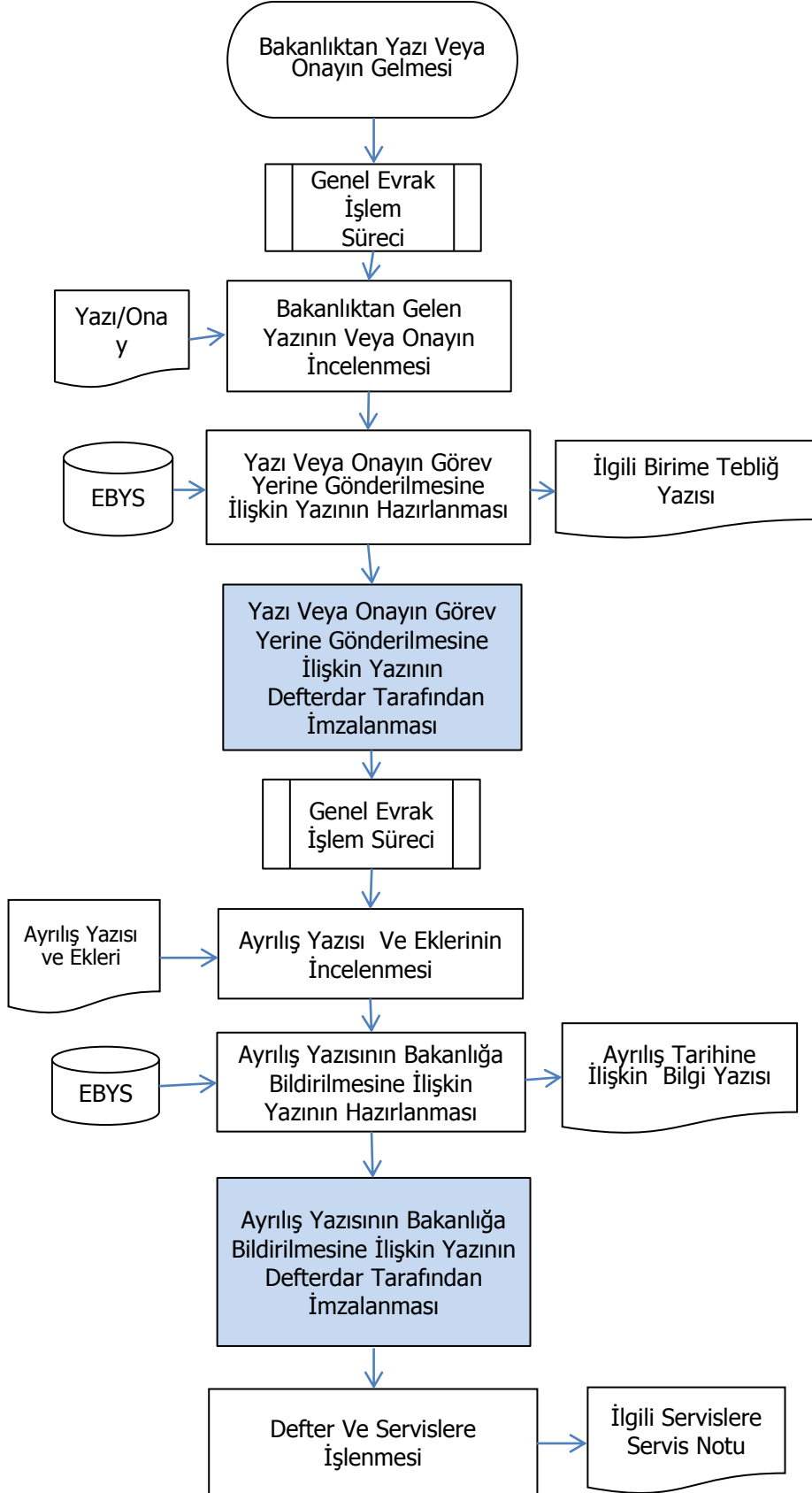

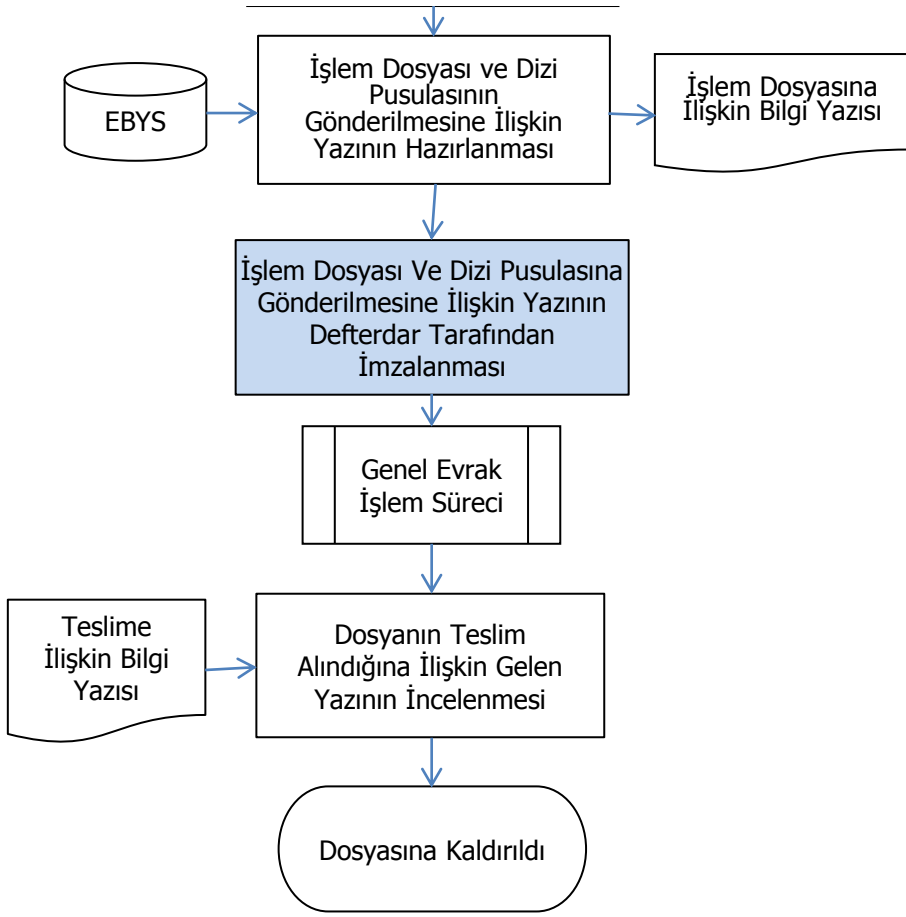

Hazırlayan:	Onaylayan:

ci

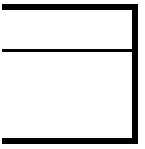



BURDUR Defter Personel Müc

Bakanlık Atamalı Personelin Göreve Başlayış İşlem Süreci

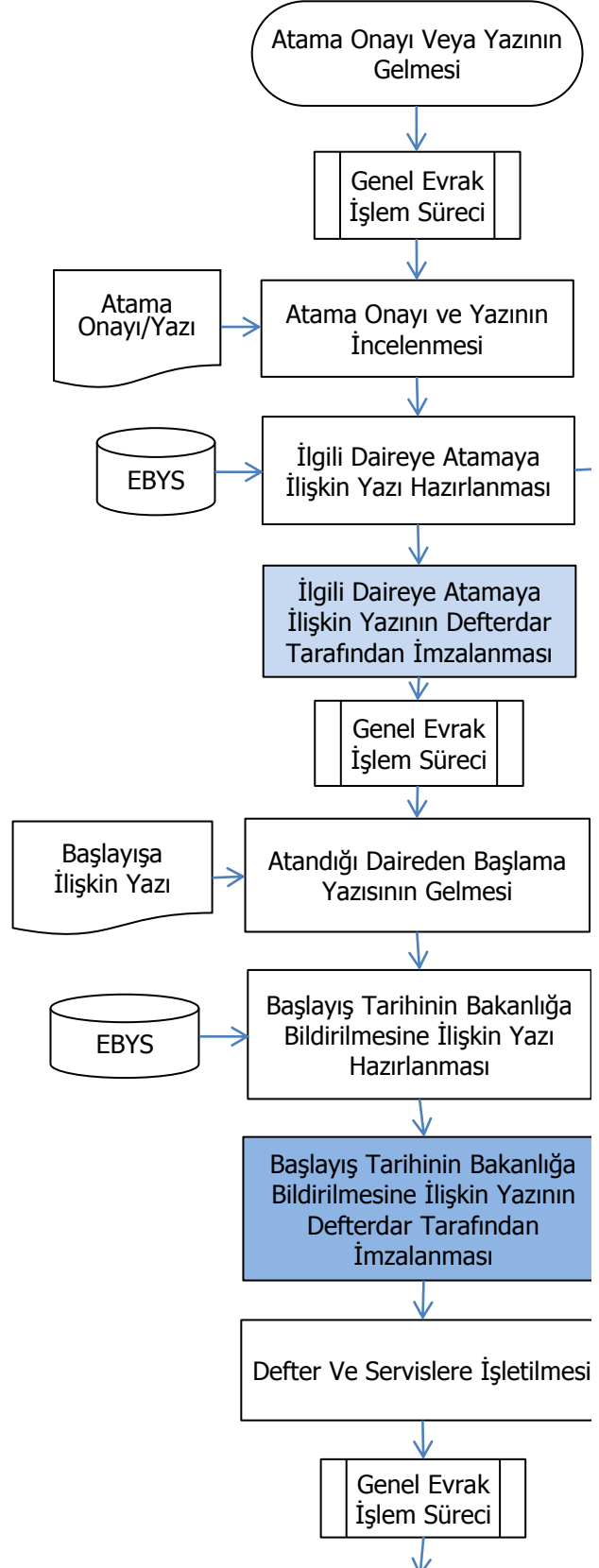

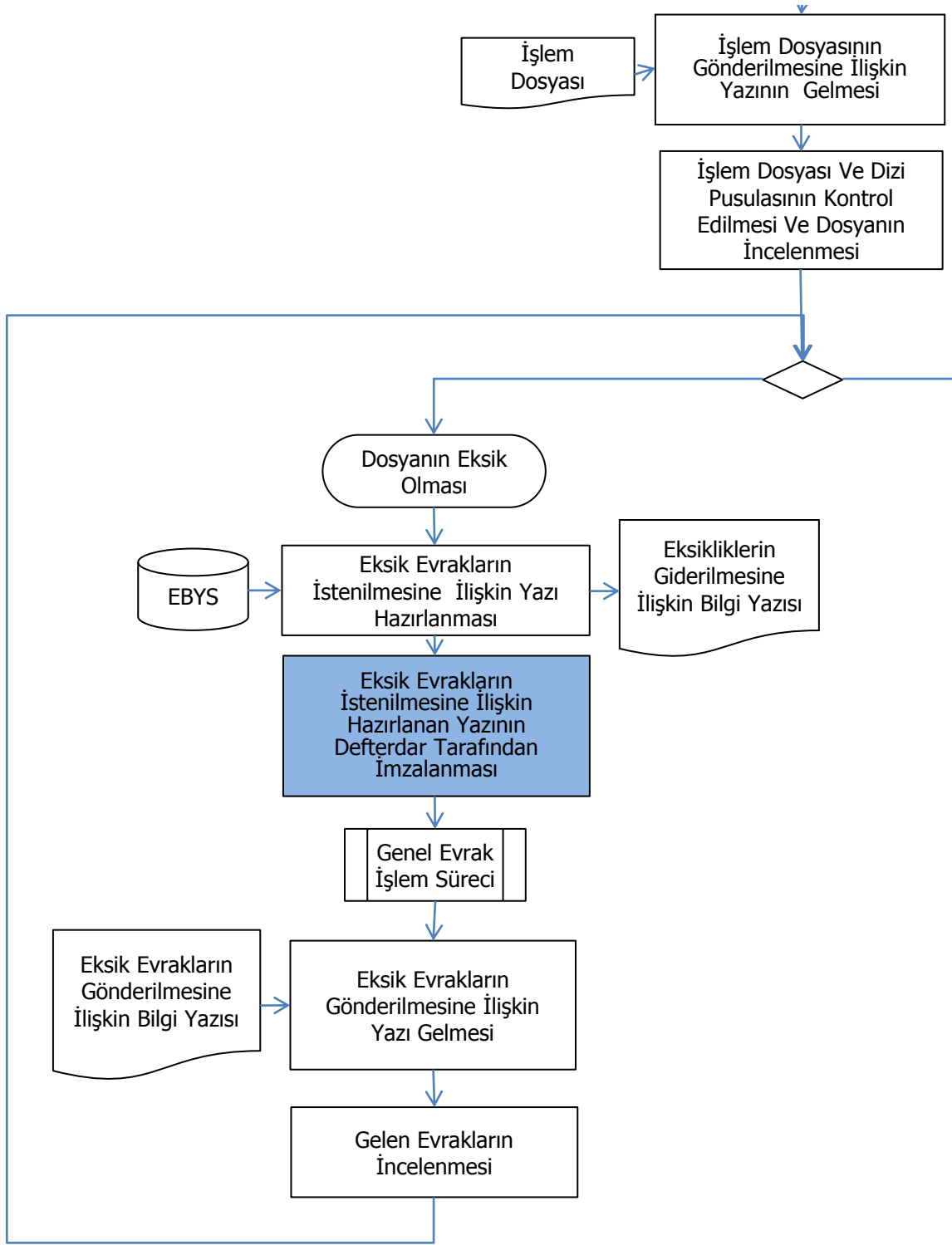

Hazırlayan:



erdarlığı dürlüğü

i

→ Yazı ve
eki Onay

→ Başlayışın
Bildirilmesine İlişkin
Yazı

İlgili
Servislere
Servis Notu

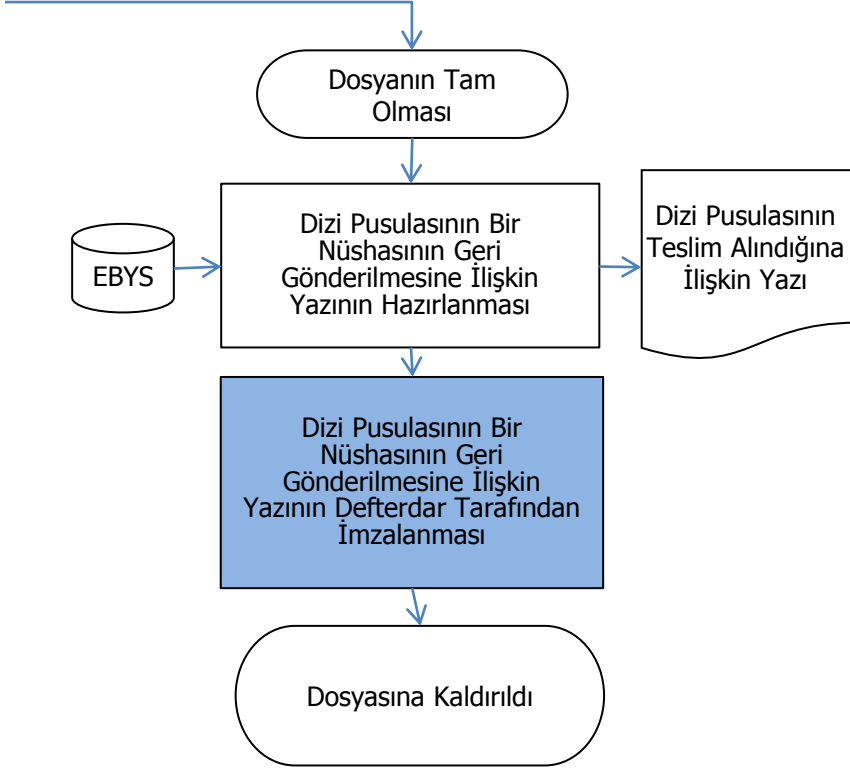

Onaylayan:





BURDUR Defterdarlığı Personel Müdürlüğü

Bakanlık Atamalı Personelin Refakat İzin Belgelerinin Gönderilmesi İşlem Süreci

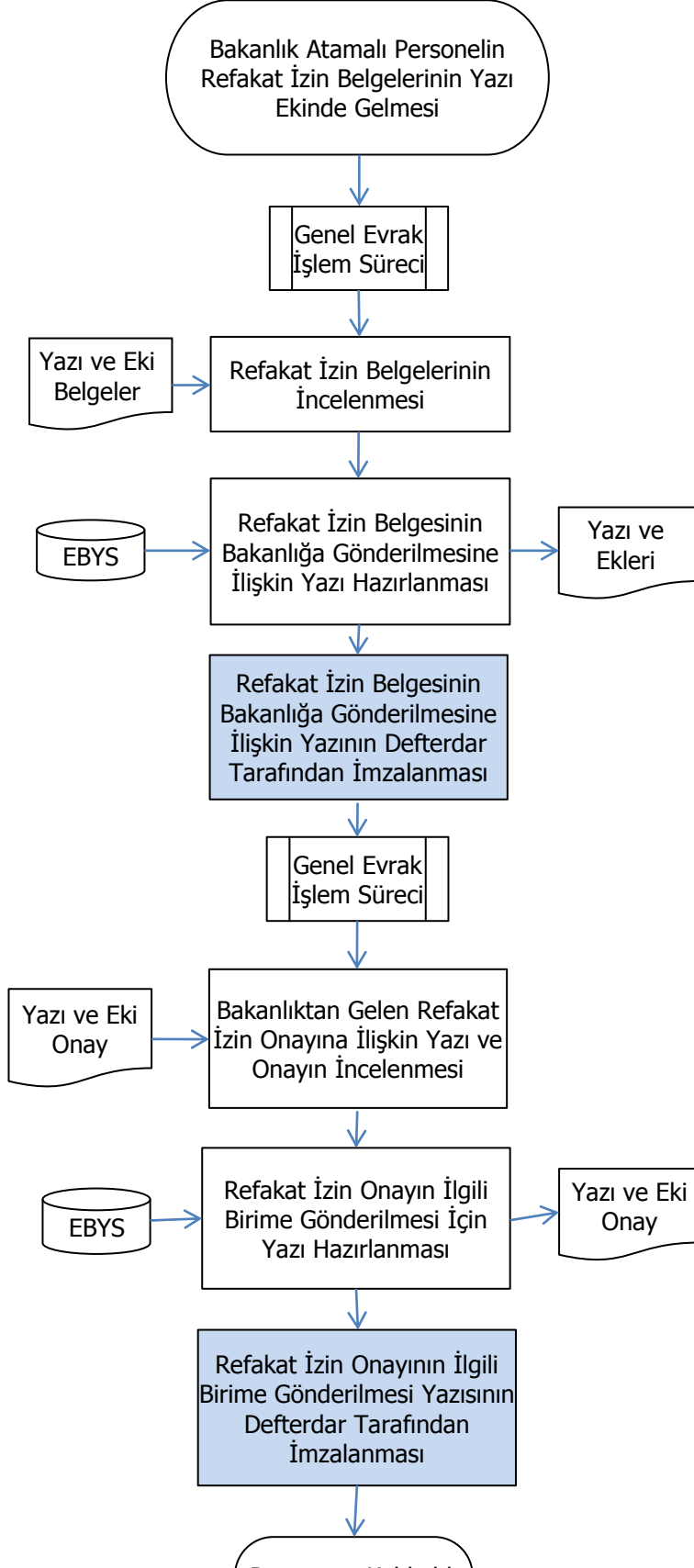

(Dosyasına Kaldırıldı)

Hazırlayan:	Onaylayan:



BURDURDefterdarlığı Personel Müdürlüğü

Dul ve Yetim Aylığı Bağlanmasına İlişkin İşlem Süreci

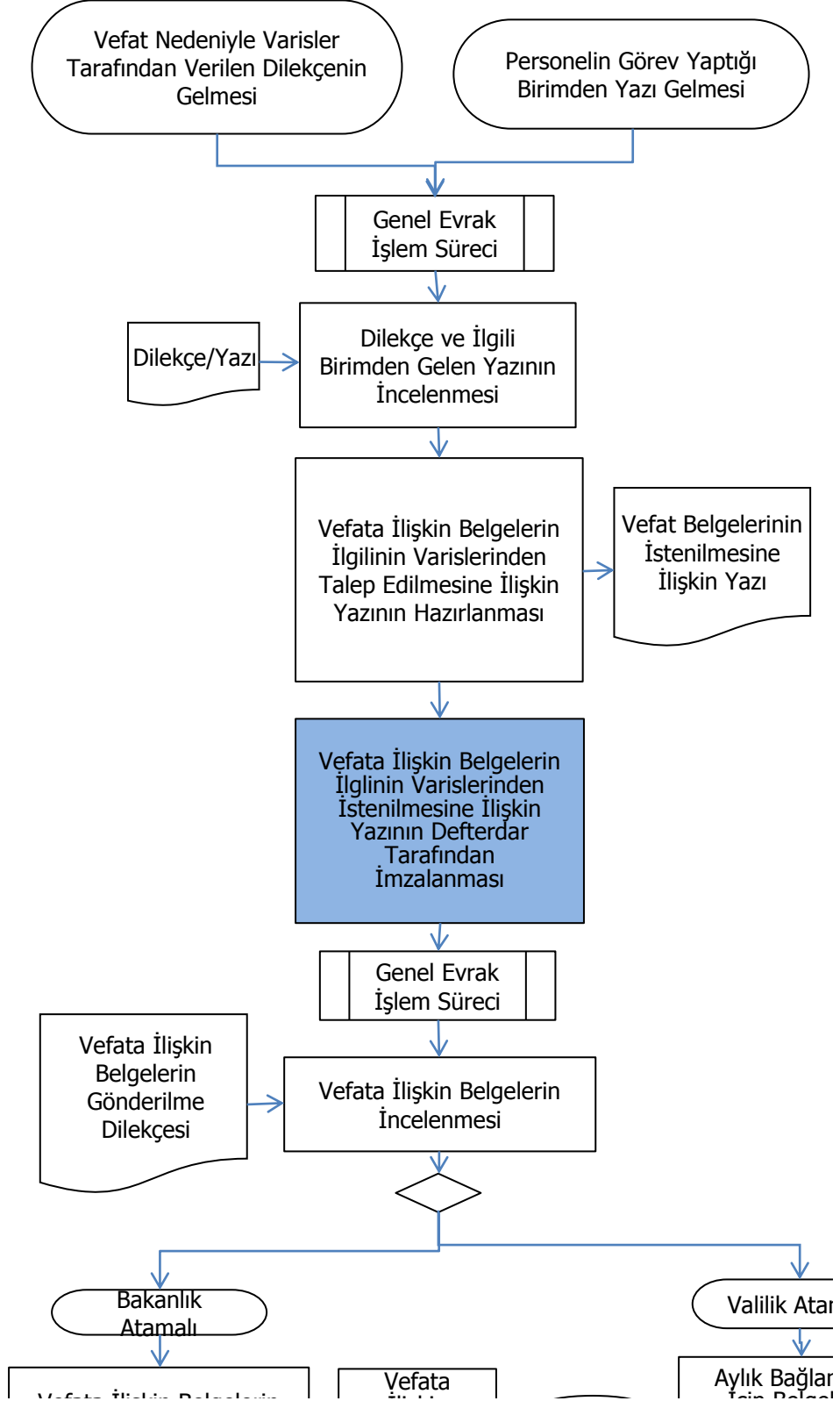

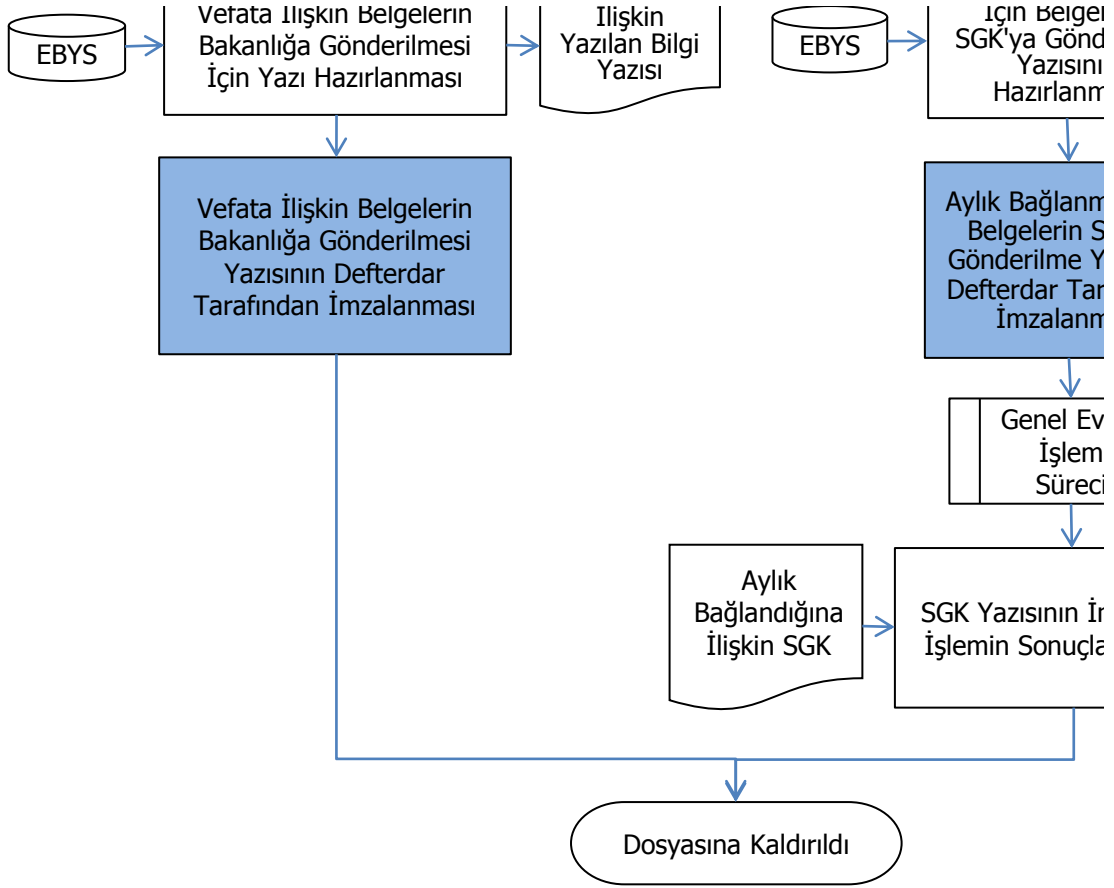

Hazırlayan:	Onaylayan:

mali

hması
Lecie

SGK'ya
Yazılan
Bilgi

lerin
lerilme
n
nası



Bılgı
Yazısı ve
Ekleri

nası İçin
SGK'ya
fazısının
rafından
nası

rak

i

ncelenerek
andırılması



BURDUR Defterdarlığı Personel Müdürlüğü Hastalık İzni İşlem Süreci

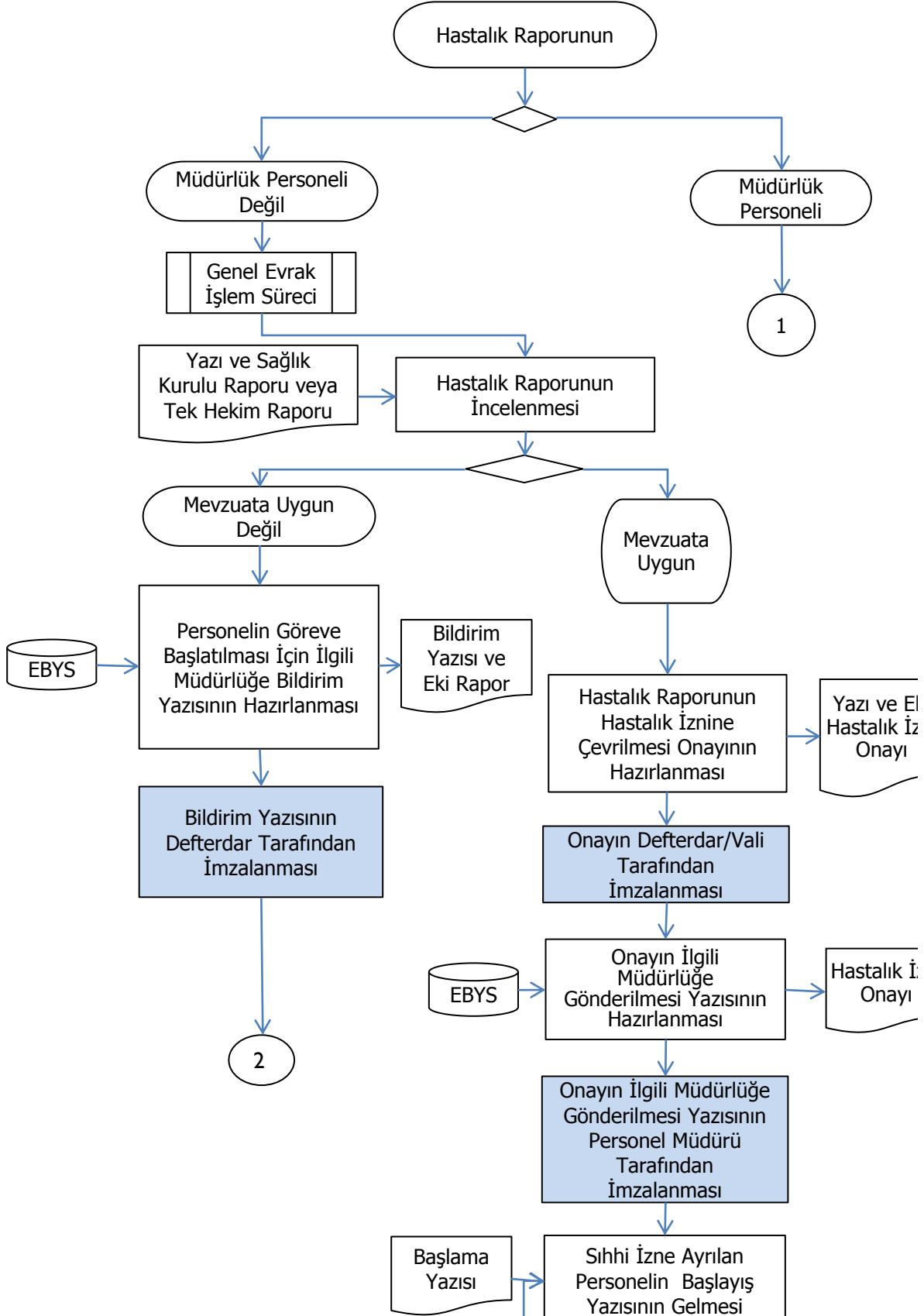

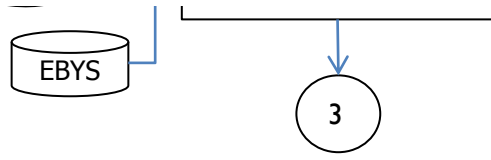

Hazırlayan:	Onaylayan:

ki
zin

zin

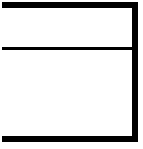



BURDUR Defterdarlığı Personel Müdürlüğü

Hastalık İzni İşlem Süreci

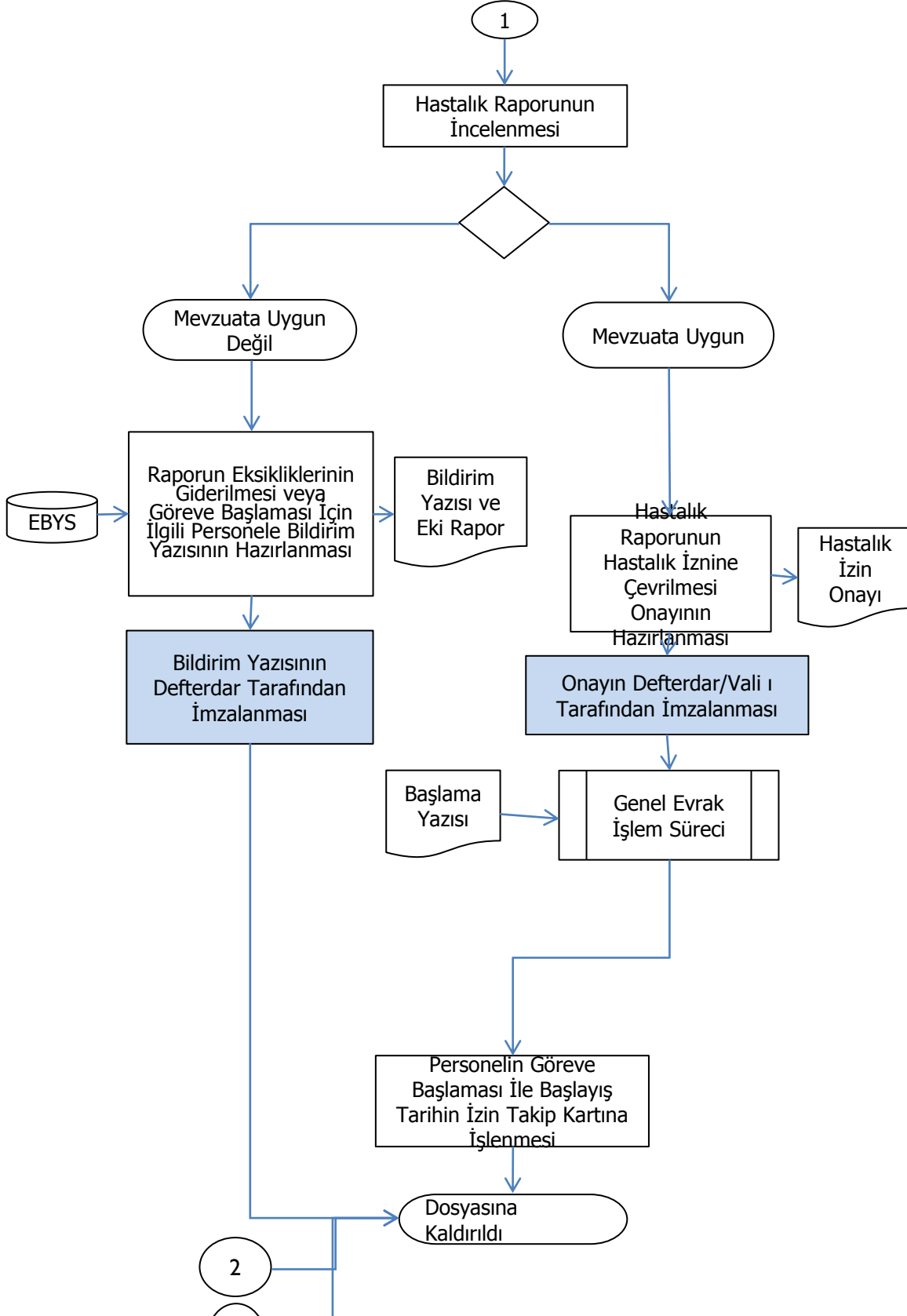

(3)

Hazırlayan:	Onaylayan:

|



BURDUR Defterdarlığı Personel Müdürlüğü

İstek ve Yaş Haddinden Emeklilik İşlemleri Süreci

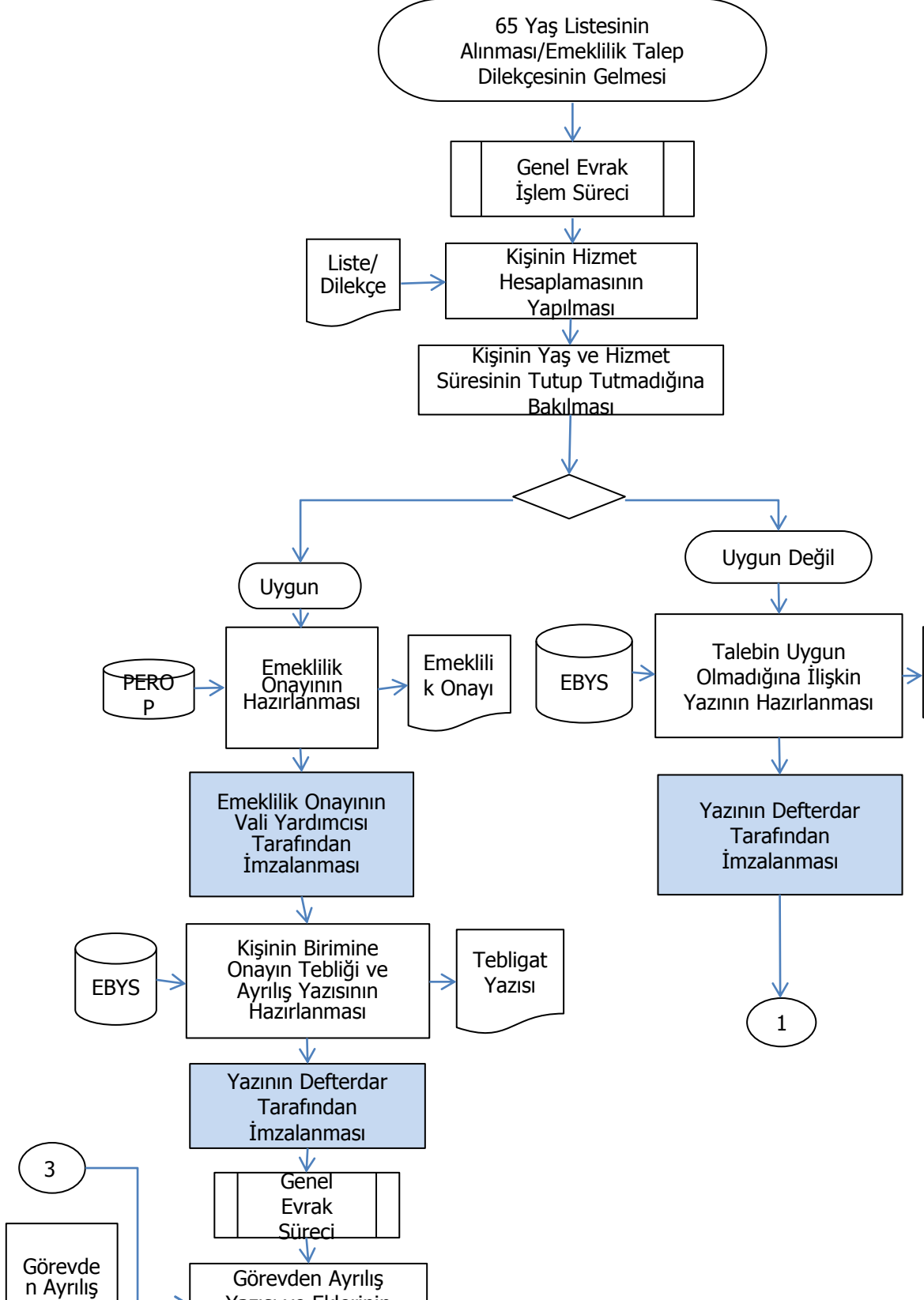

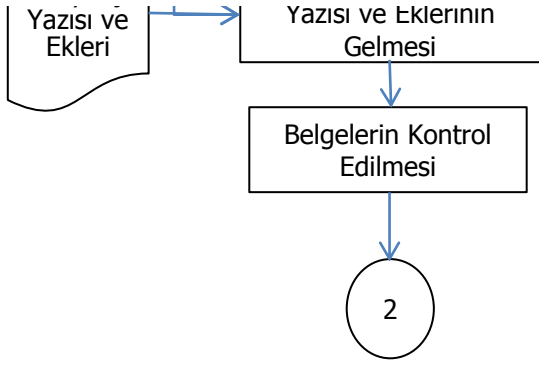

Hazırlayan:	Onaylayan:



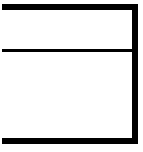

BURDUR Defterdarlığı Personel Müdürlüğü İstek ve Yaş Haddinden Emeklilik İşlemleri Süreci

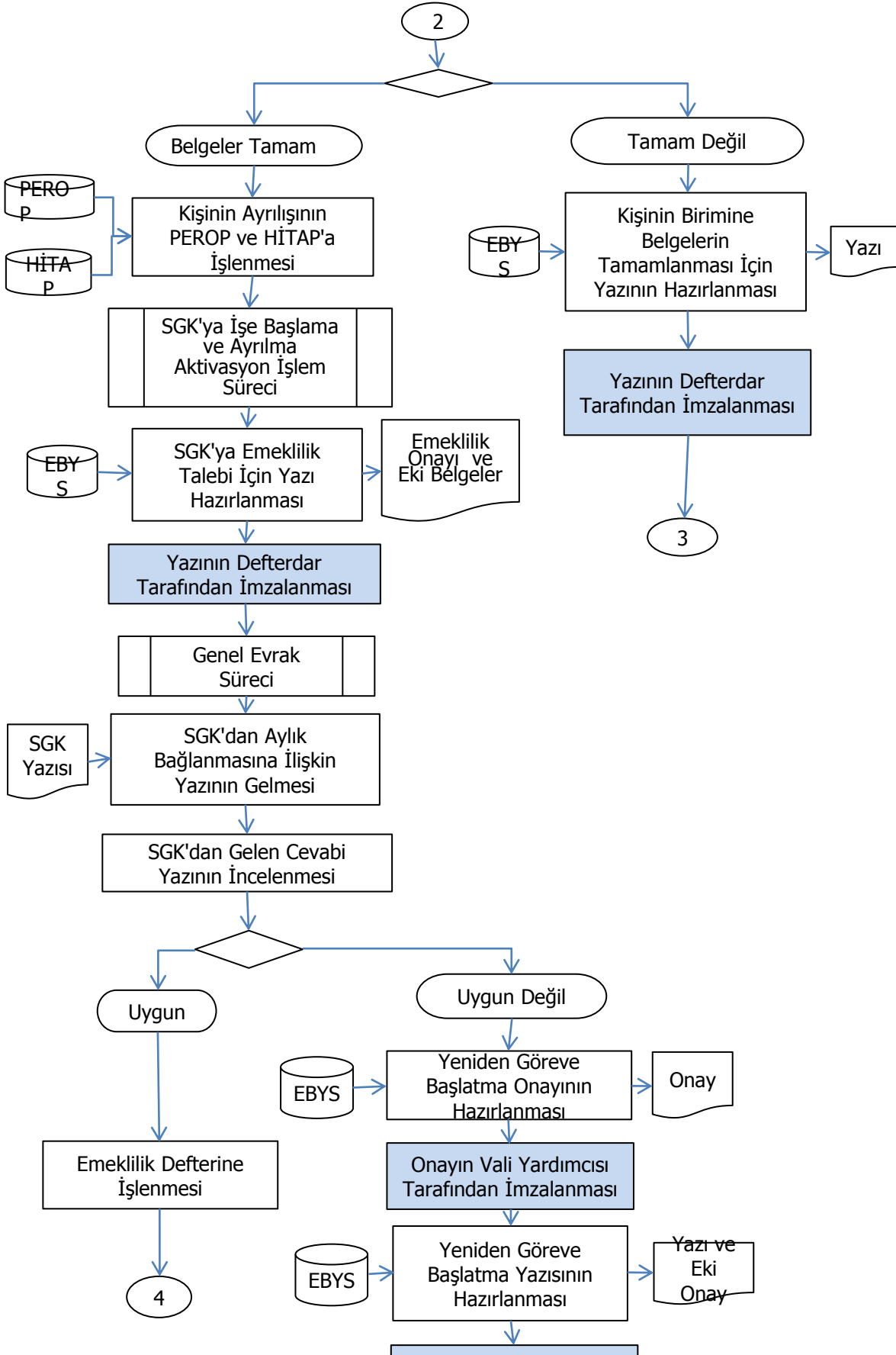

Yazının Defterdar
Tarafından İmzalanması

5

Hazırlayan:	Onaylayan:



BURDUR Defterdarlığı Personel Müdürlüğü İstek ve Yaş Haddinden Emeklilik İşlemleri Süreci

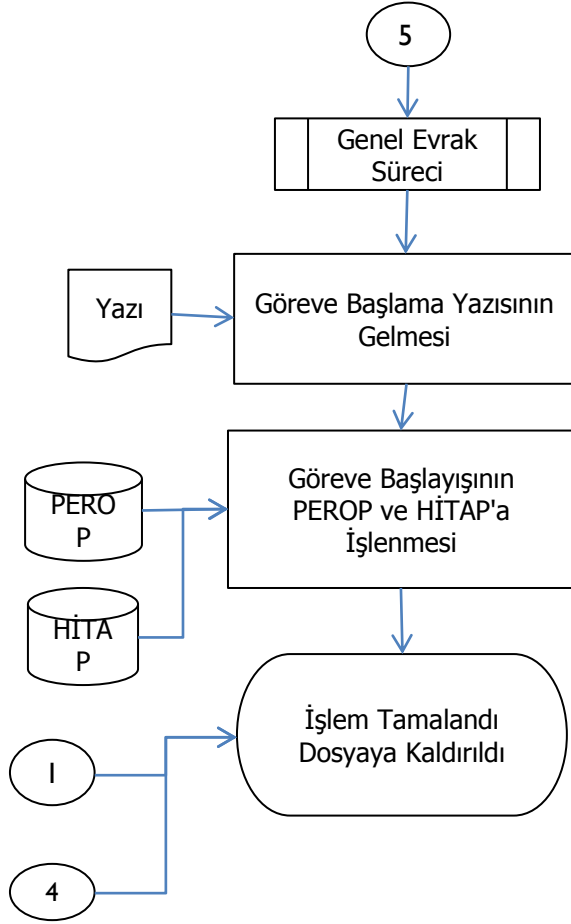

Hazırlayan:

Onaylayan:





BURDUR Defterdarlığı Personel Müdürlüğü

Emeklilik (Malulen, Re'sen) İşlem Süreci

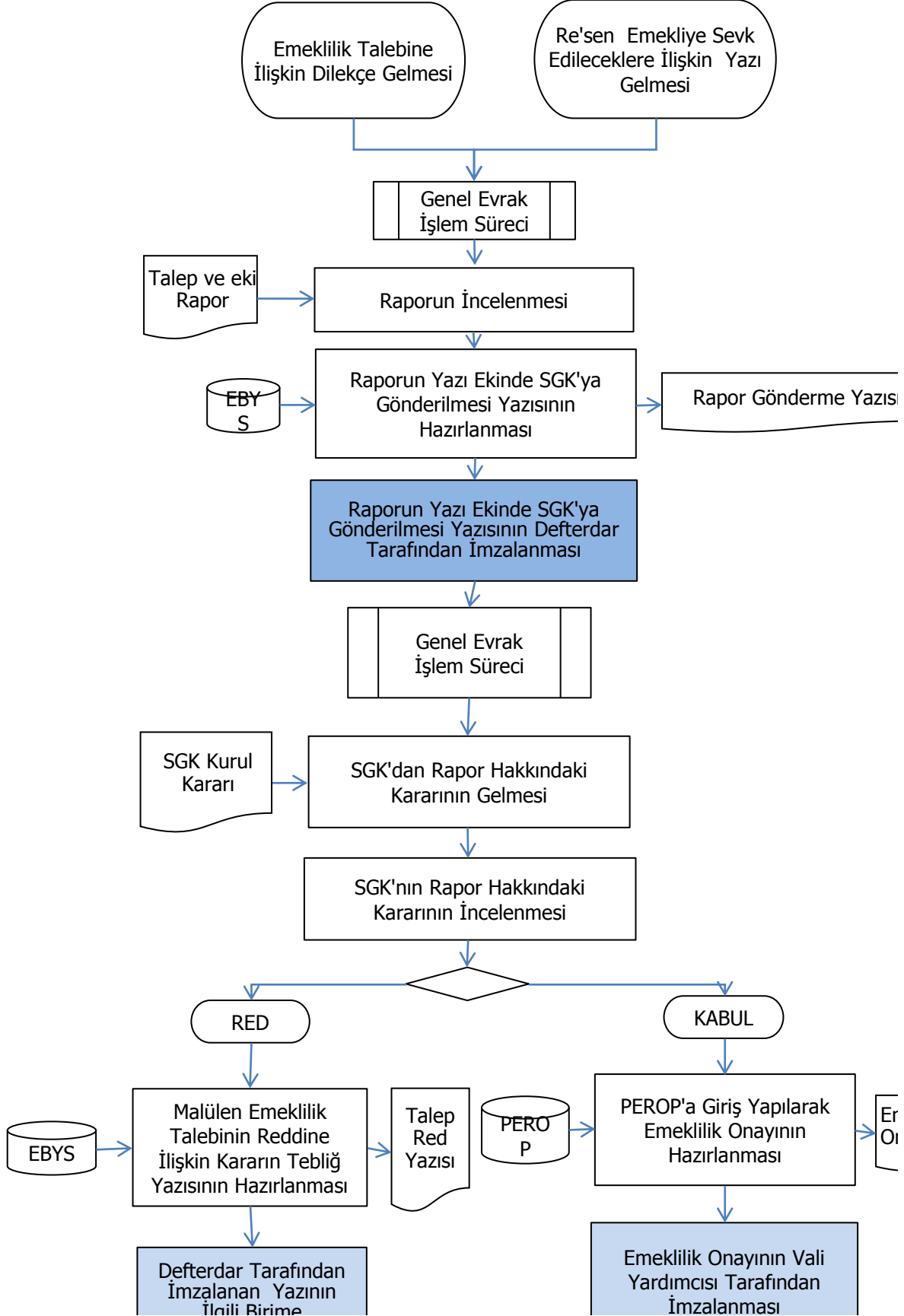

İçin Birim
Gönderilmesi



1



2

Hazırlayan:	Onaylayan:



meklilik
nayı

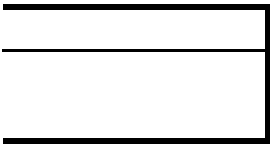

BURDUR Defterdarlığı Personel Müdürlüğü Emeklilik (Malulen, Re'sen) İşlem Süreci

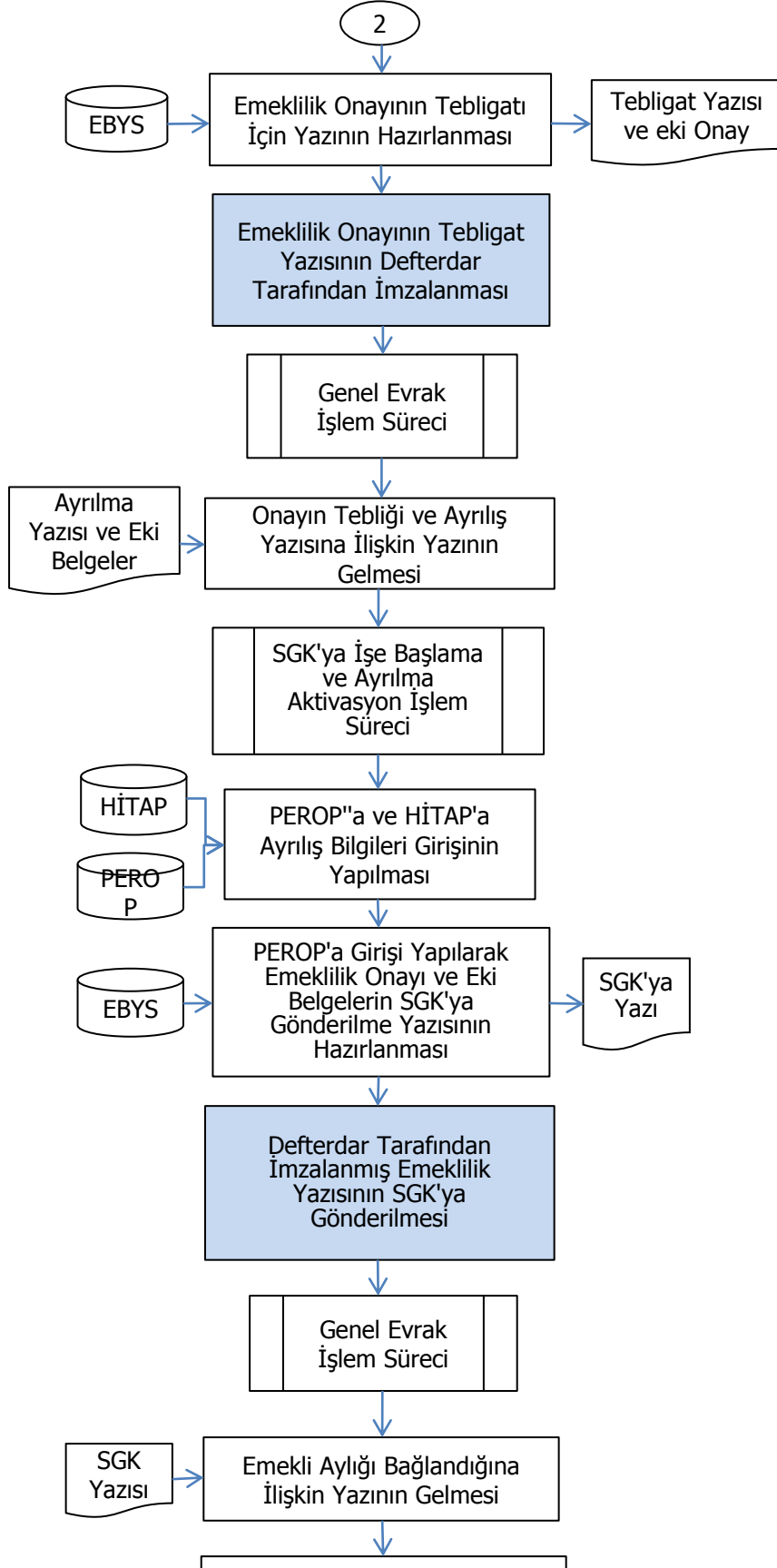

SGK Yazısının İncelenerek
İşlemin Sonuçlandırılması

1

Dosyasına Kaldırıldı

Hazırlayan:

Onaylayan:

--	--



BURDUR Defterdarlığı Personel Müdürlüğü

Muvafakat Verme İşlem Süreci

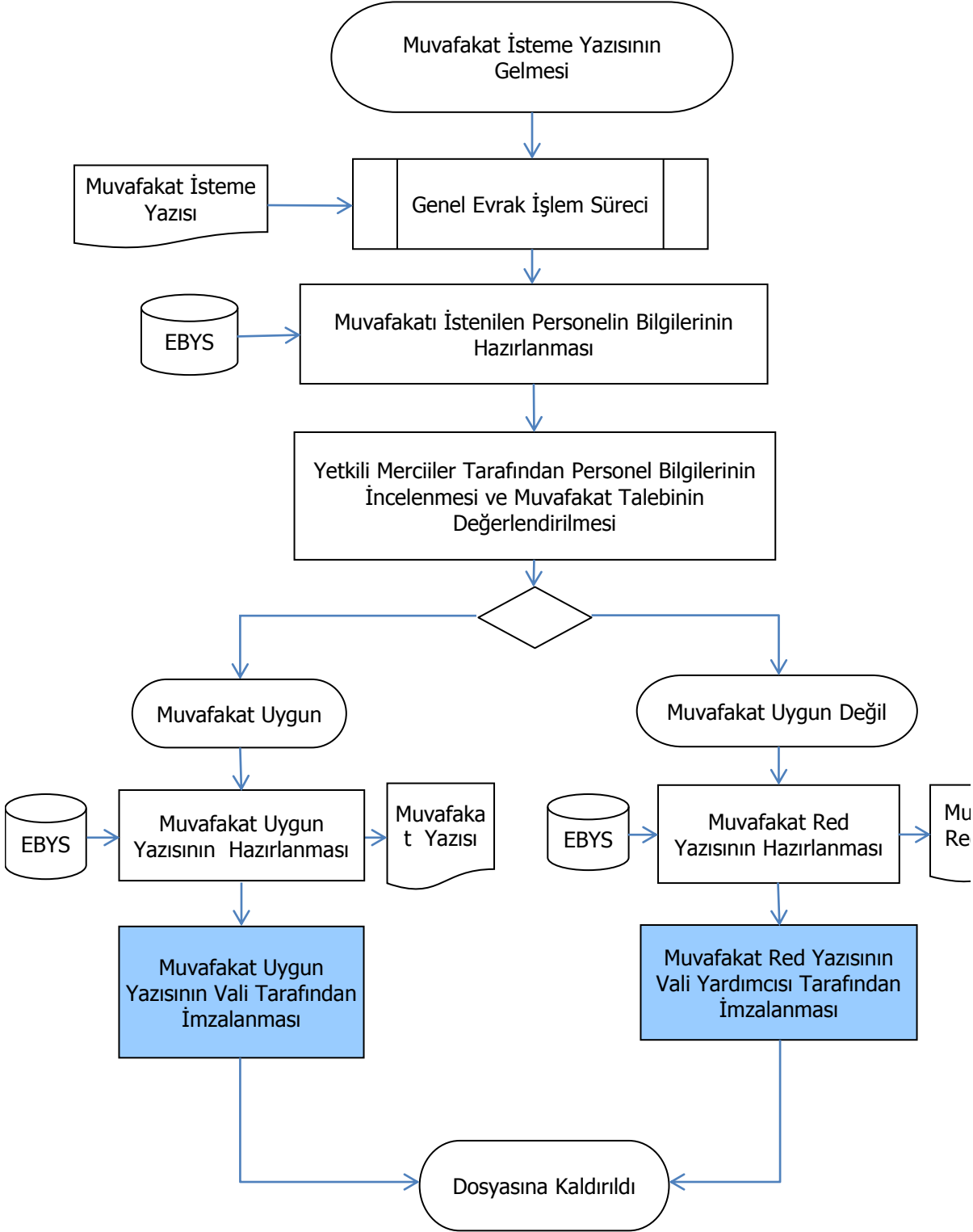

Hazırlayan:	Onaylayan:

ivafakat
d Yazısı

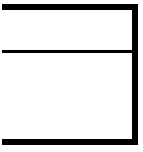



BURDUR Defterdarlığı Personel Müdürlüğü Öğrenim Değişikliği İşlem Süreci

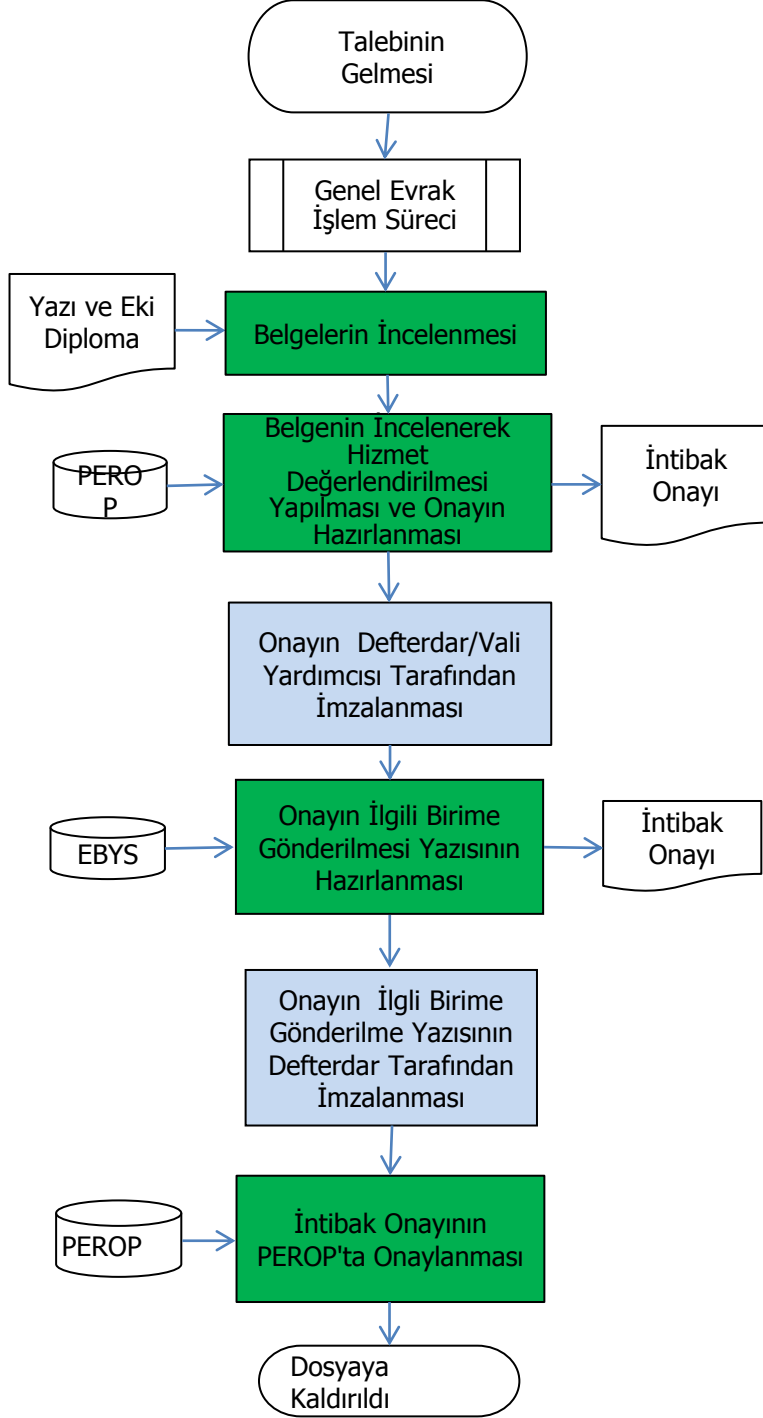

Hazırlayan:	Onaylayan:



BURDUR Defterdarlığı Personel Müdürlüğü SGK'ya İşe Başlama ve Ayrılma Aktivasyon

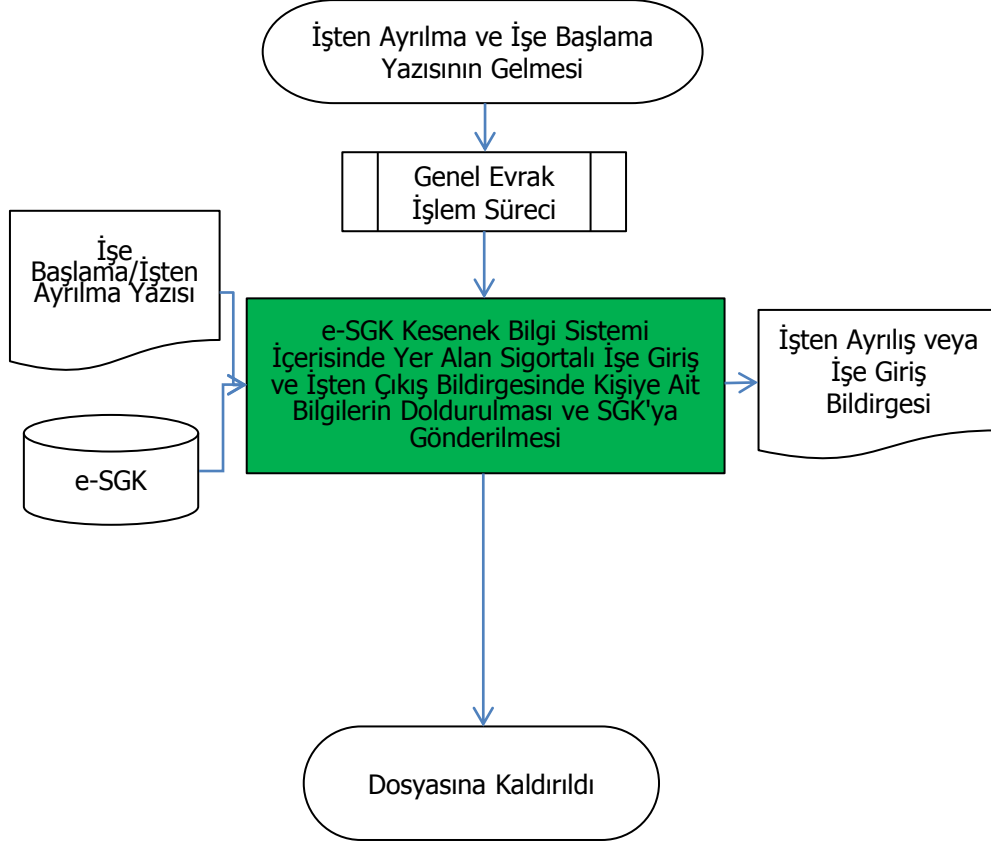

Hazırlayan:	Onaylayan:
	Personel Müdür V.



Hazırlayan:

BURDUR Defterdarlı Personel Müdürlüğü

657 S.K. 64/4 Maddesi İle 68/B Maddesinin
Uygulanacaklara İlişkin Yazı/Dilekçenin
Gelmesi

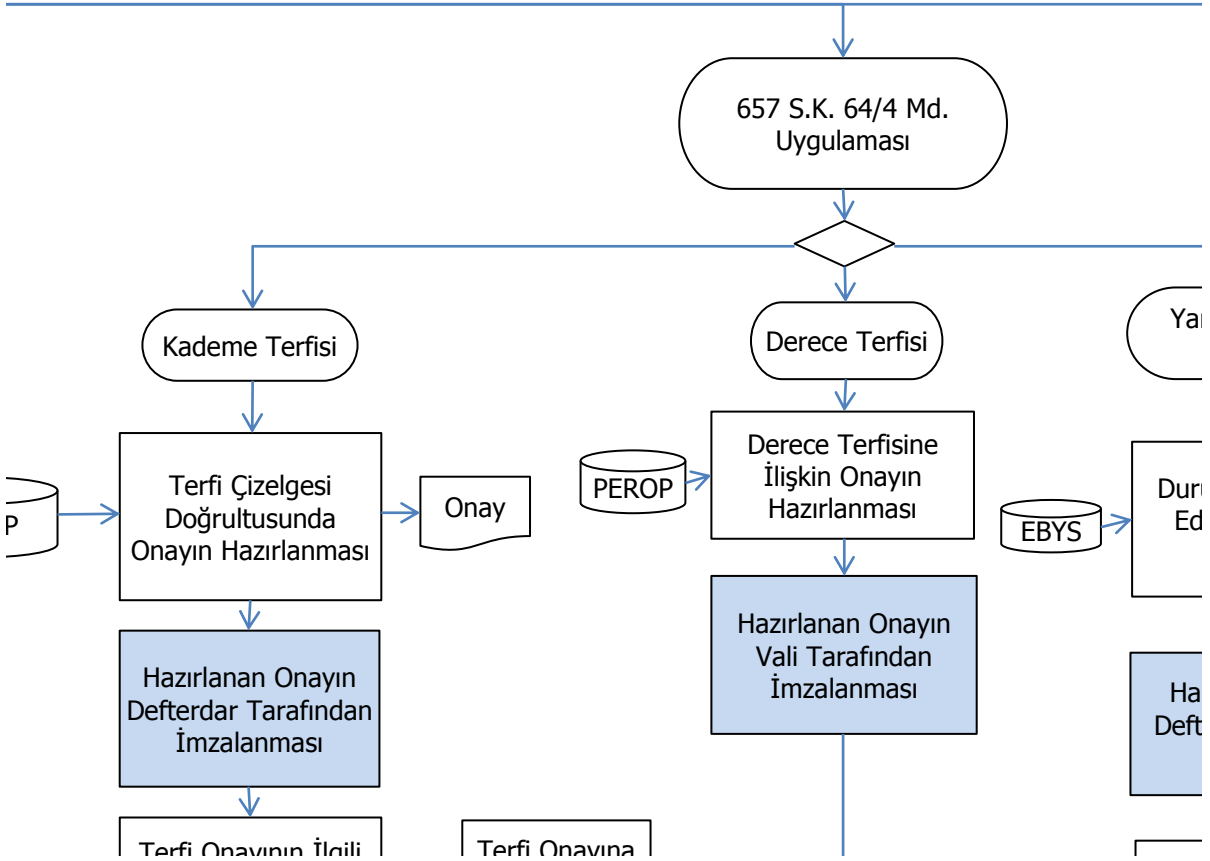

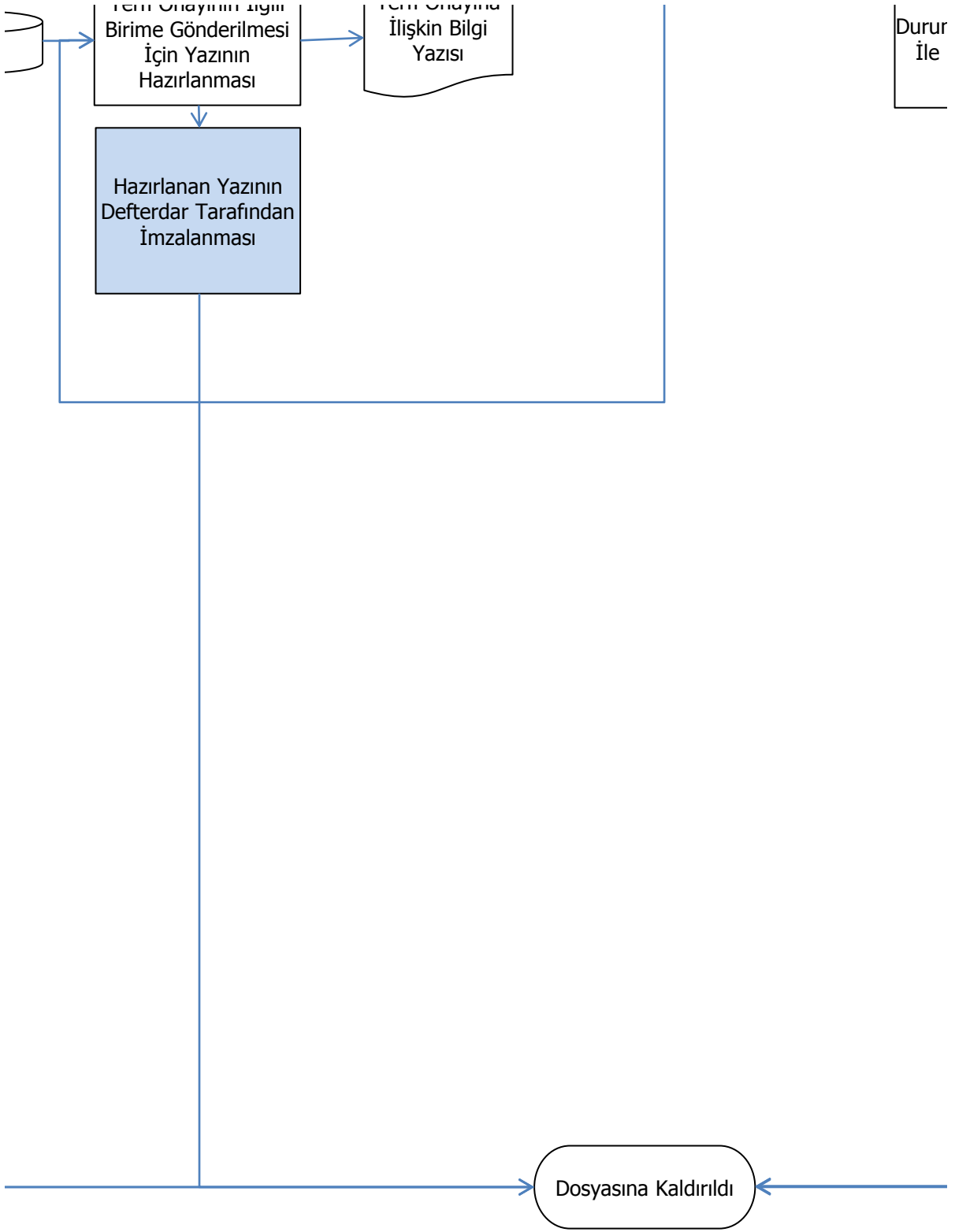

	Onaylayan

İlgili Yazı

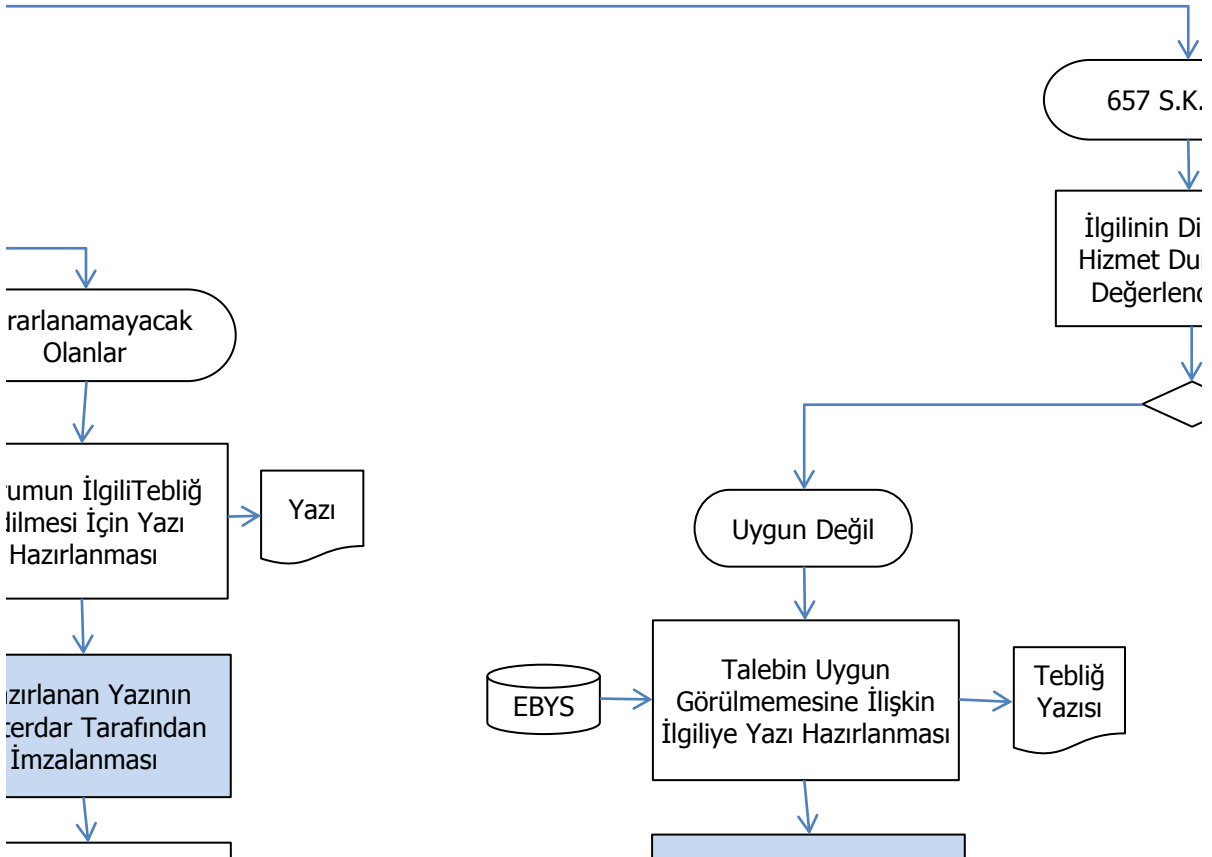

nun Özlük Ve Arşiv
Disiplin Servisine
İşletilmesi



Servis
Notu

Hazırlanan Yazının
Defterdar Tarafından
İmzalanması



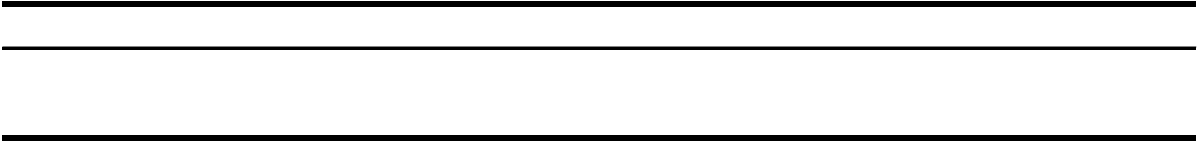

. 68/B

isiplin Ve
rumunun
dirilmesi

Servis Notu



Uygun

Kadro Servisinden
Kadro İstenilmesi

Servis
Notu

Servis Notu

Kadro Servisince Boş

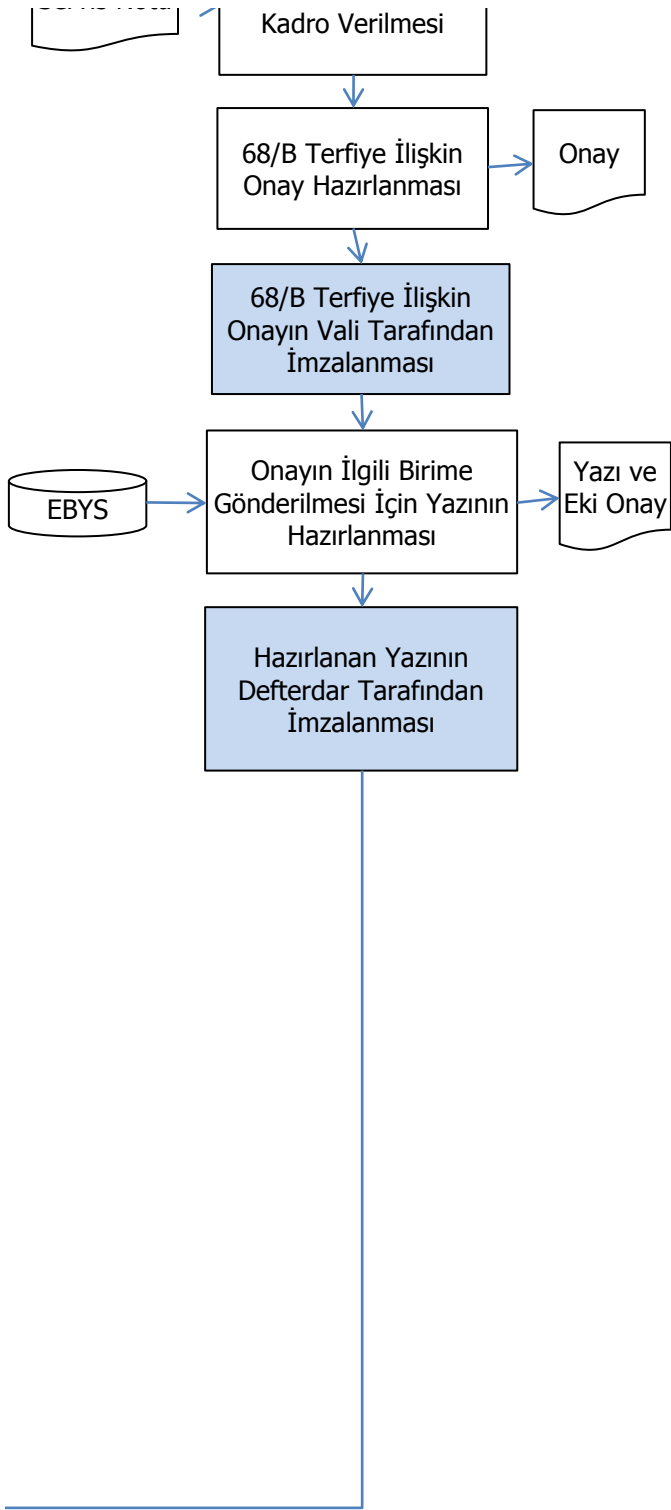



BURDUR Defterdarlığı Personel Müdürlüğü

Valilik Atamalı Personelin Refakat İzin İşlem Süreci

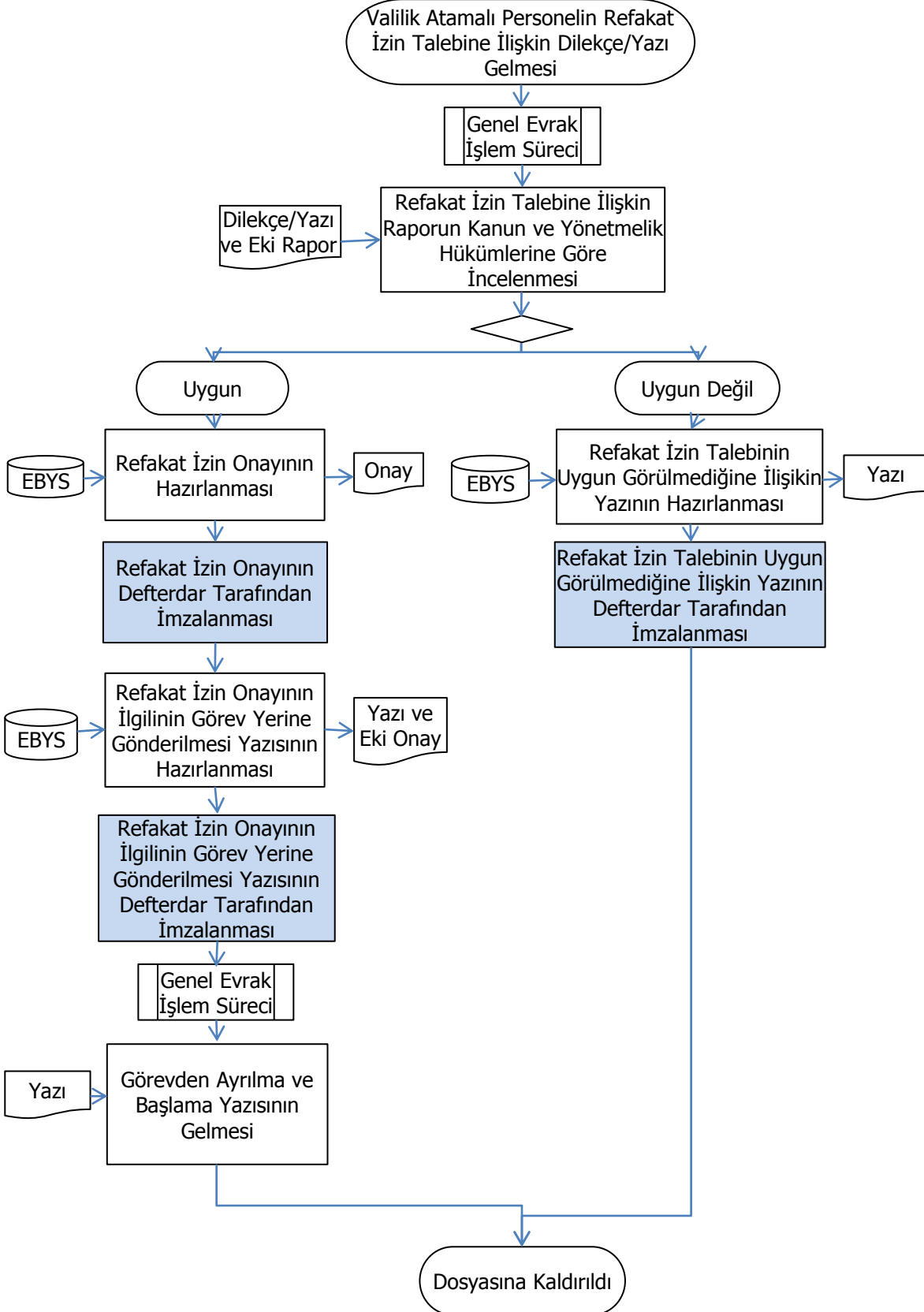

Hazırlayan:

Onaylayan:

--	--



BURDUR Defterdarlığı Personel Müdürlüğü

Vekalet İşlem Süreci

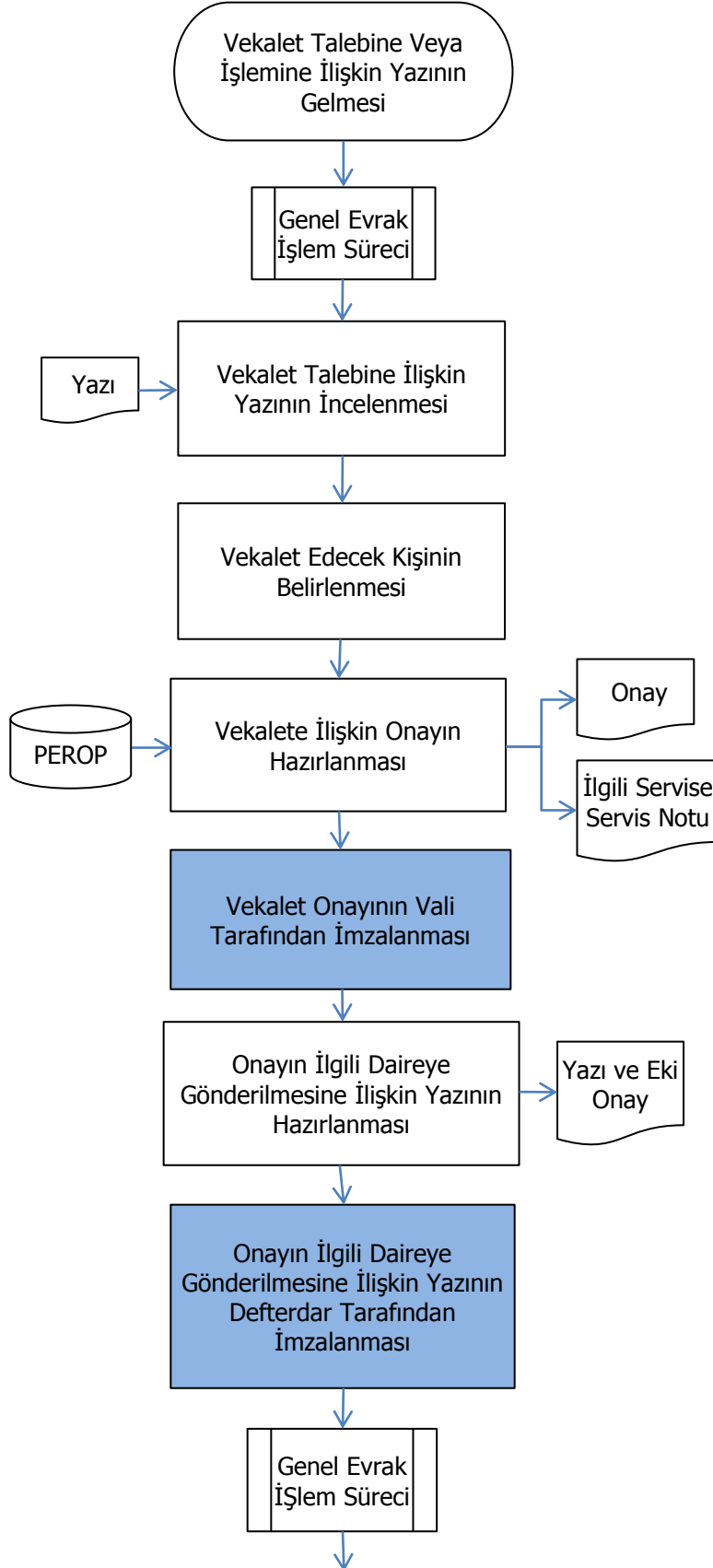

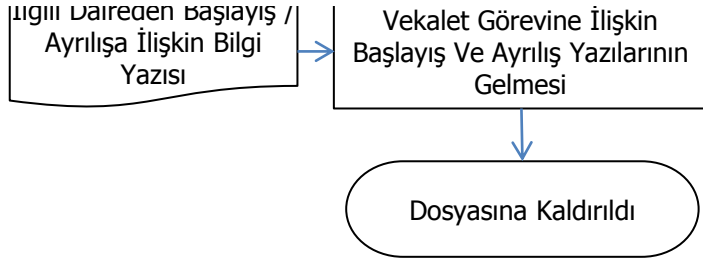

Hazırlayan:	Onaylayan:

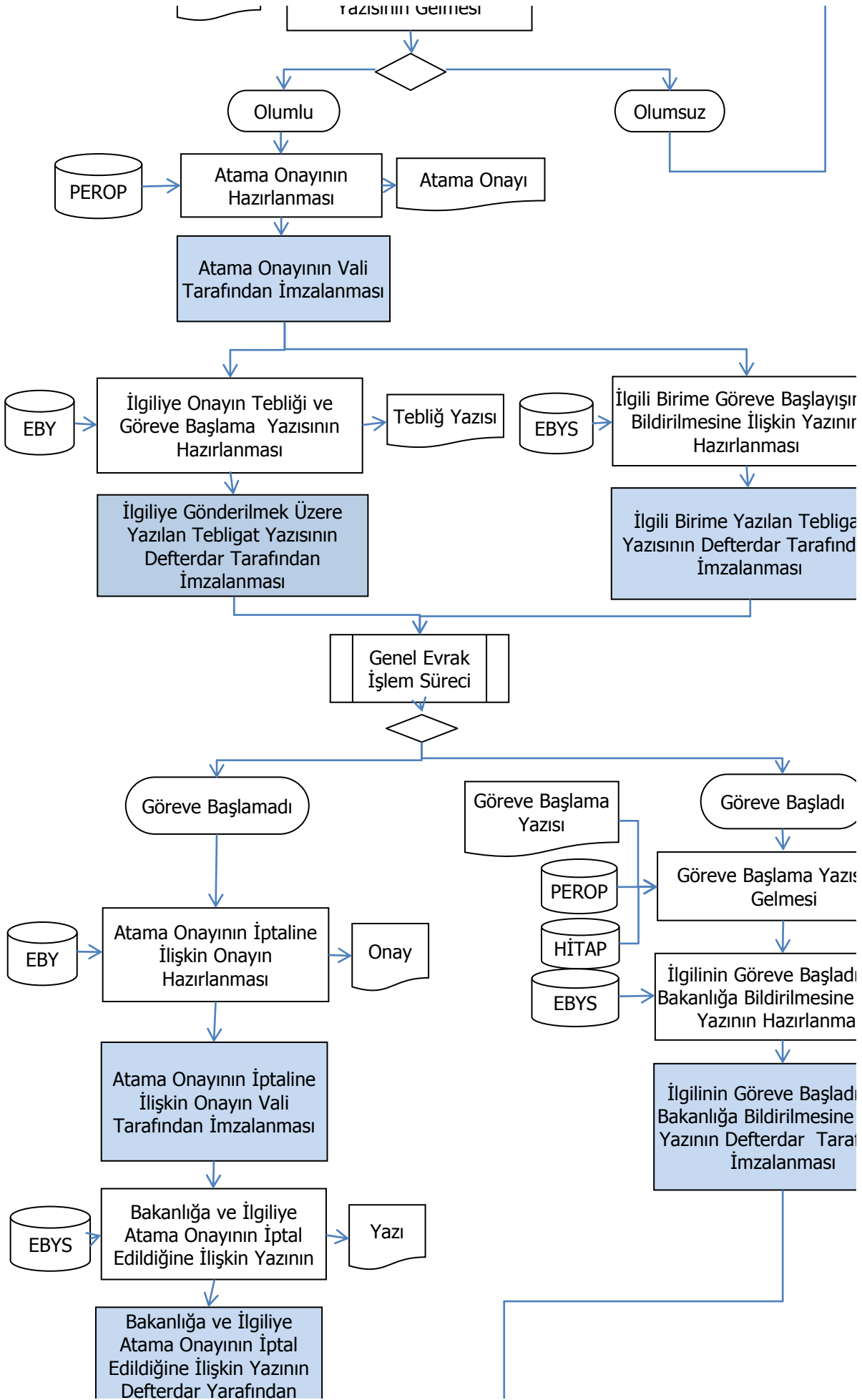

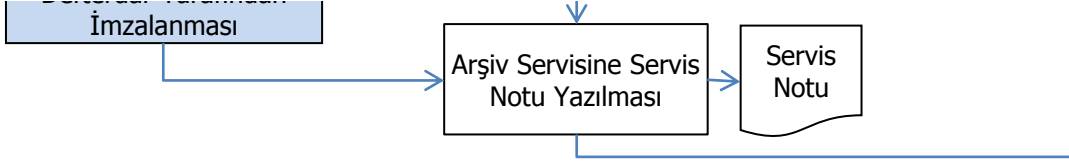

Hazırlayan:	Onaylayan:

İlgili
Yazı

)

]

1
3
→

Yazı

1
3
r

]

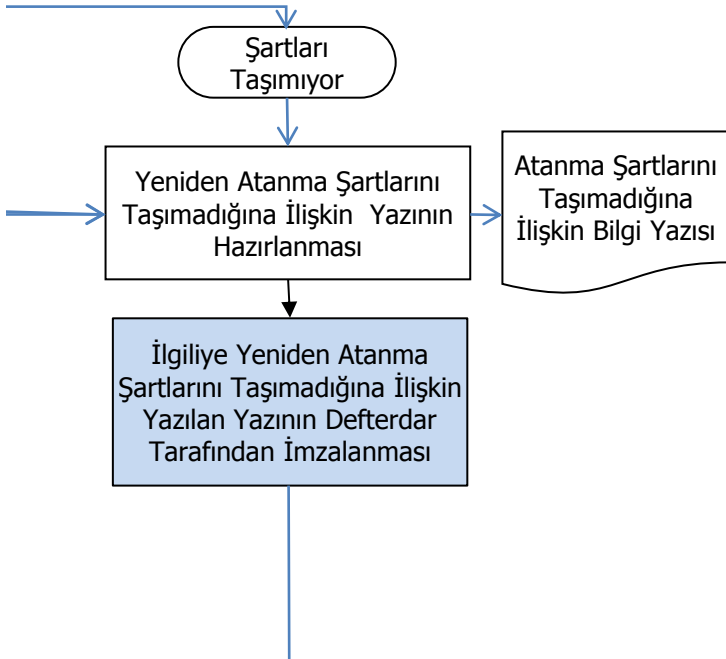

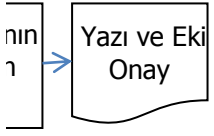

at
lan

)

sının

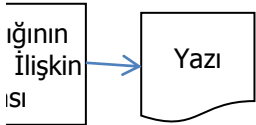

ğının
İlişkin
findan

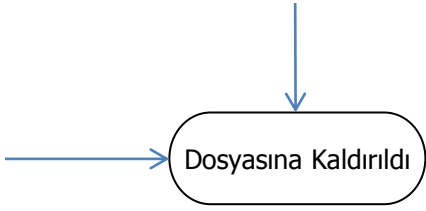



BURDUR Defterdarlığı Personel Müdürlüğü

Yıllık İzin İşlem Süreci

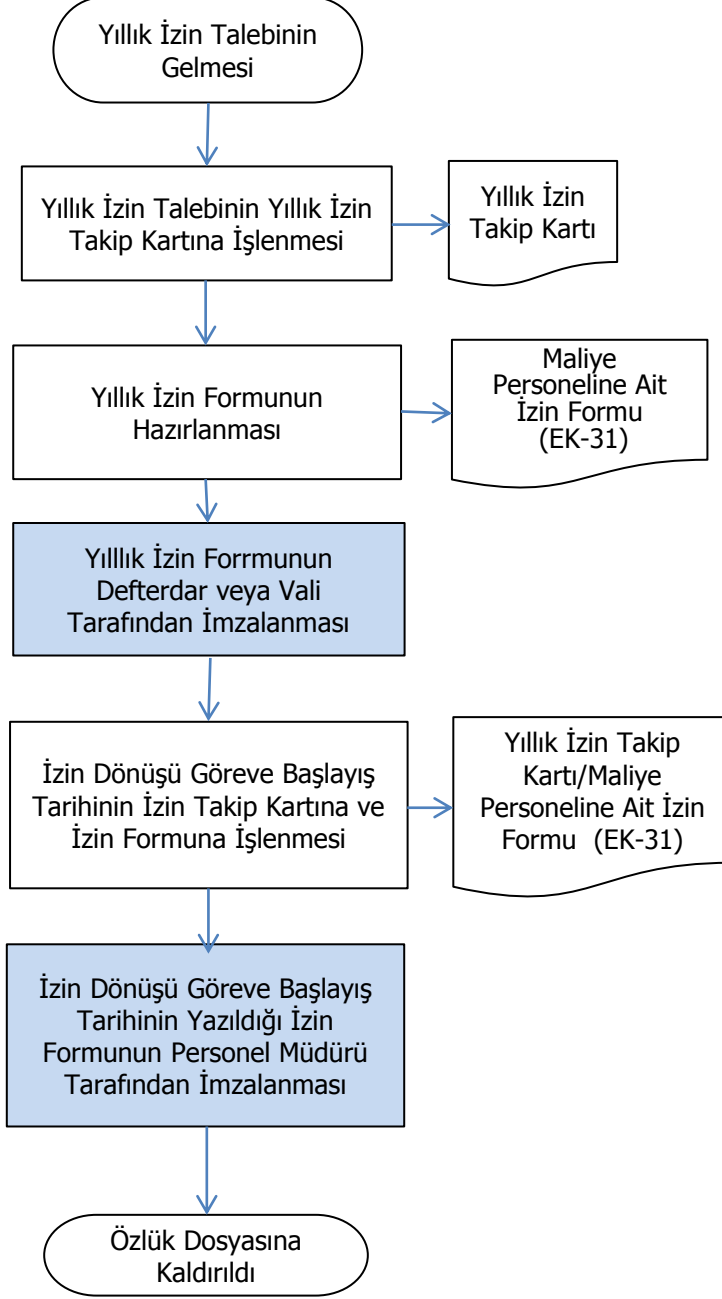

Hazirlayan:	Onaylayan:



BURDUR Defterdarlığı Personel Müdürlüğü

Yıl Sonu İzin İşlemleri Süreci

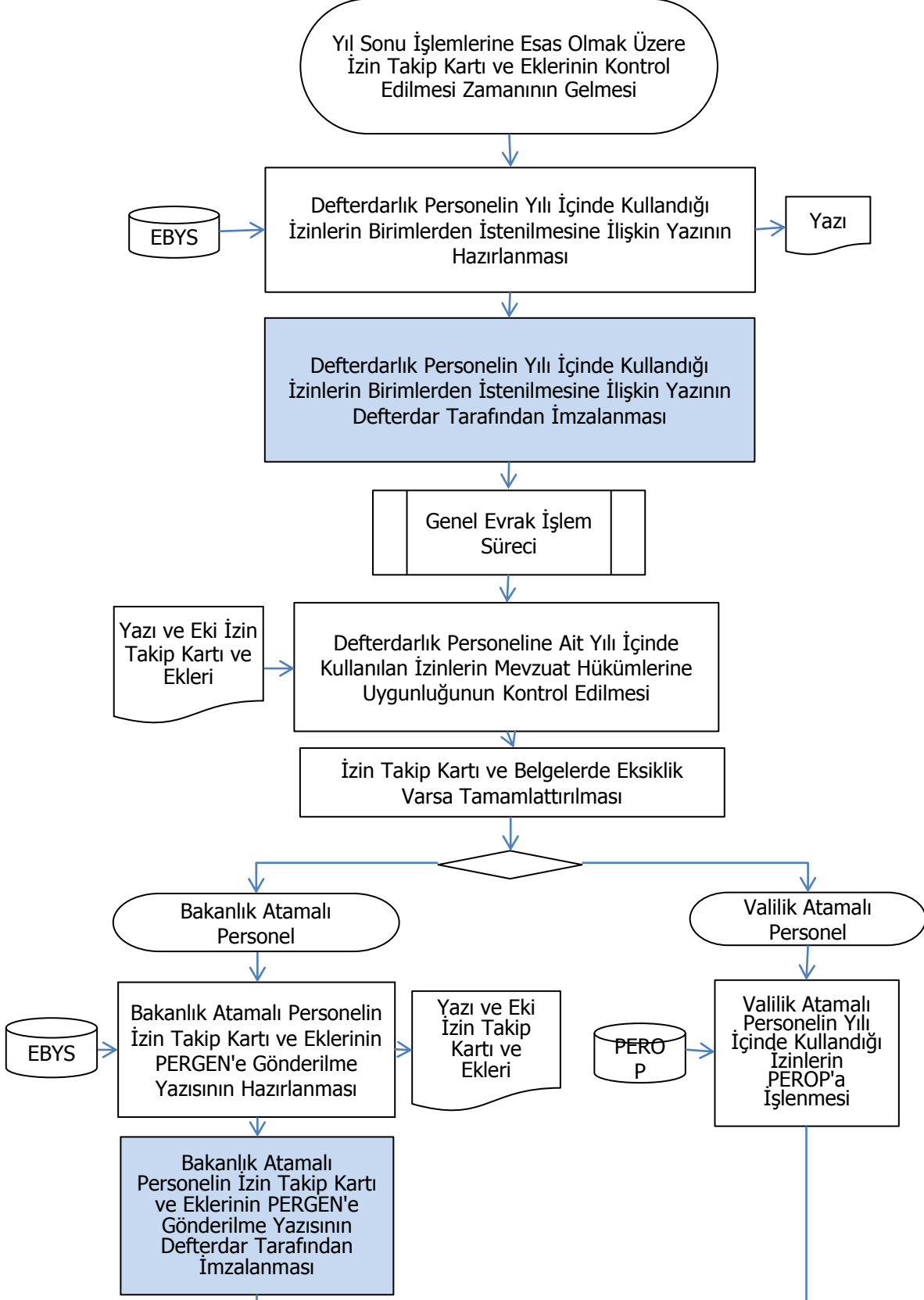

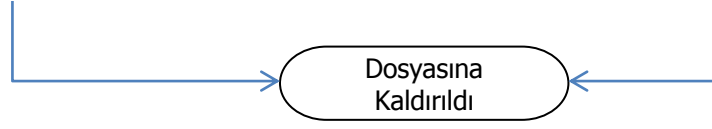

Hazırlayan:	Onaylayan:

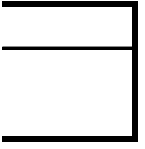



BURDUR Defterdarlığı Personel Müdürlüğü İşçi ve 4-C li Personelin İzin İşlem Süreci

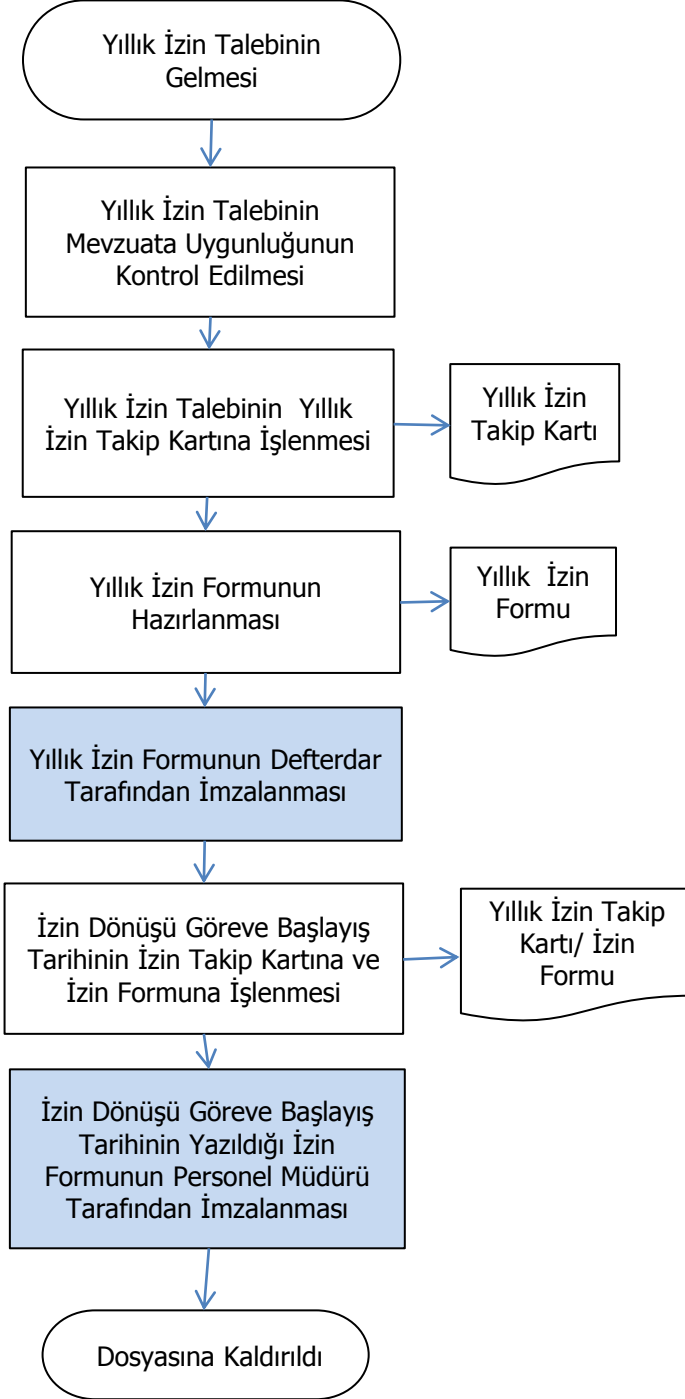

Hazırlayan:	Onaylayan:

Görevden Uzaklaştırma ve Göreve İade İşlemleri Süreci

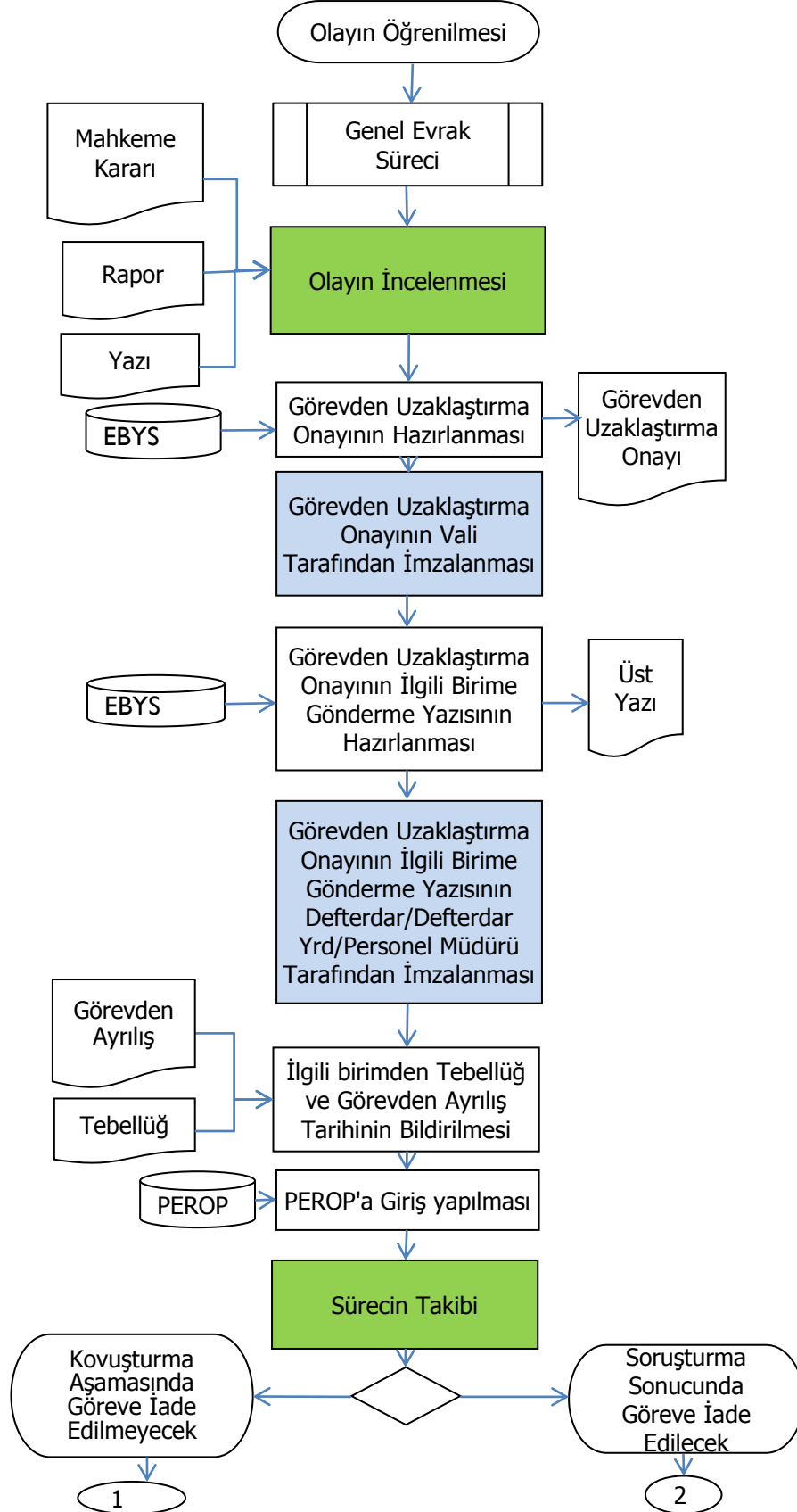

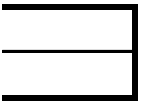

Görevden Uzaklaştırma ve Göreve İade İşlemleri Süreci

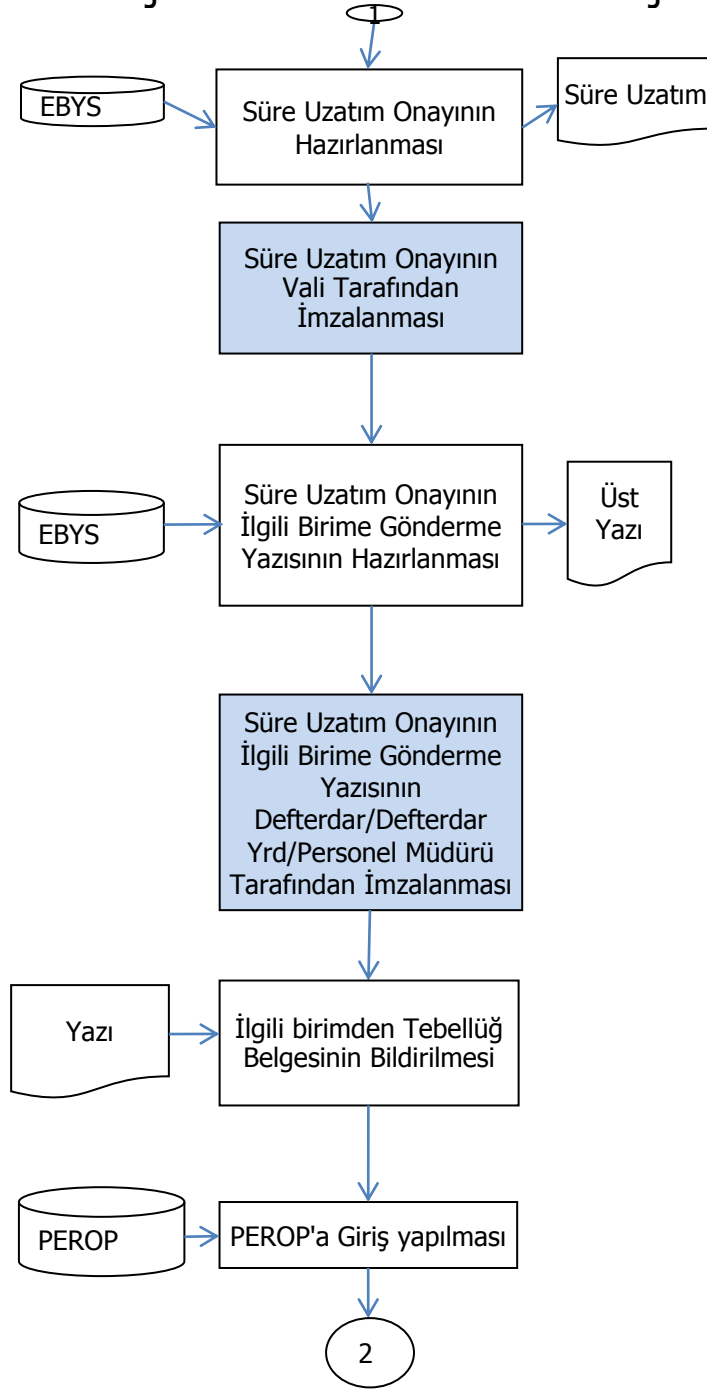

Hazırlayan:

Onaylayan:

eci

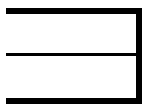

Görevden Uzaklaştırma ve Göreve İade İşlemleri Süreci:

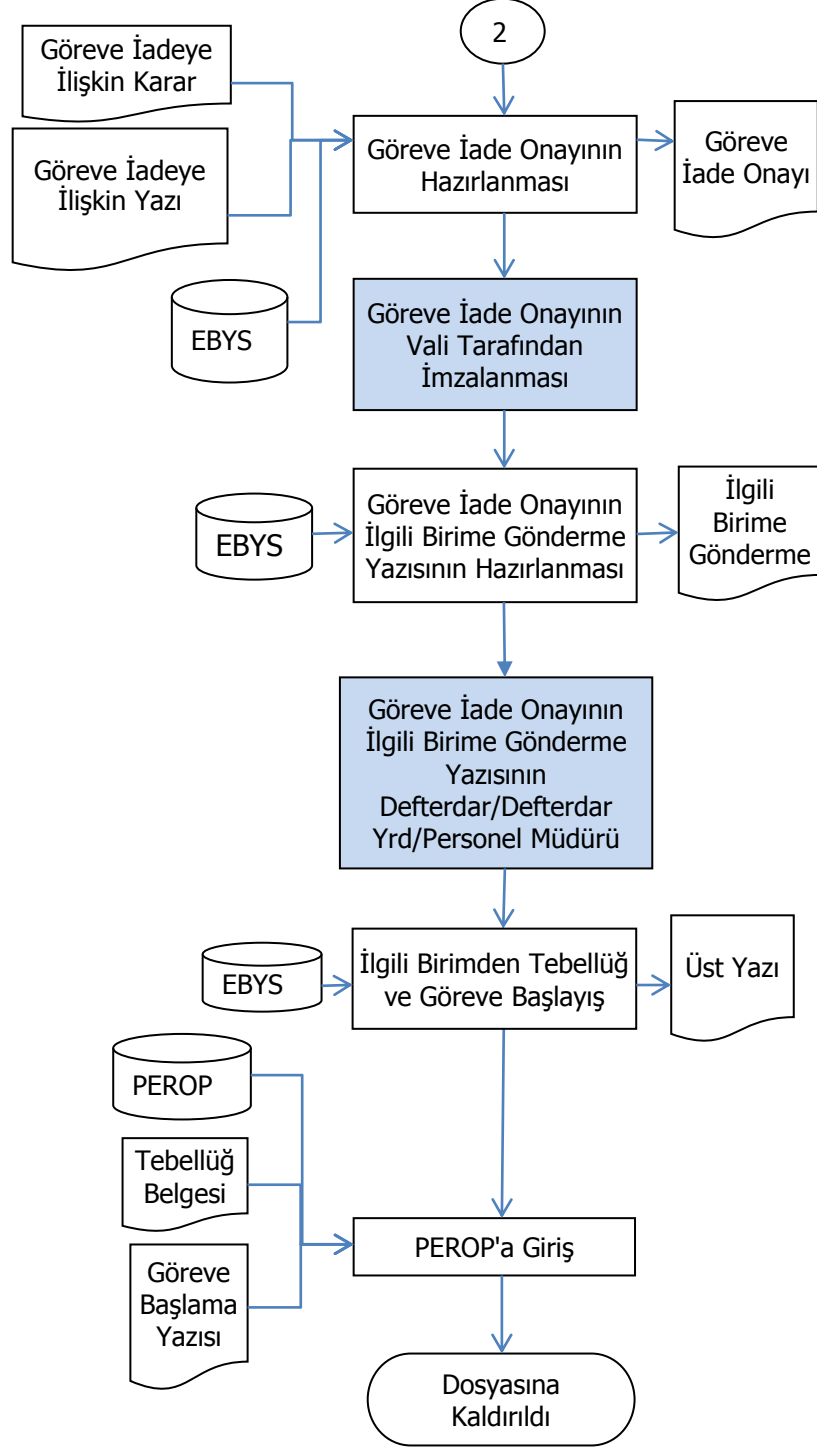

Hazırlayan:

Onaylayan:

i

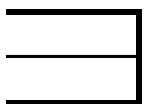

BURDUR Defterdarlığı Personel Müdürlüğü Kesinleşen Mahkeme Kararı Üzerine Yapılacak İşlemlerin Akış Şeması

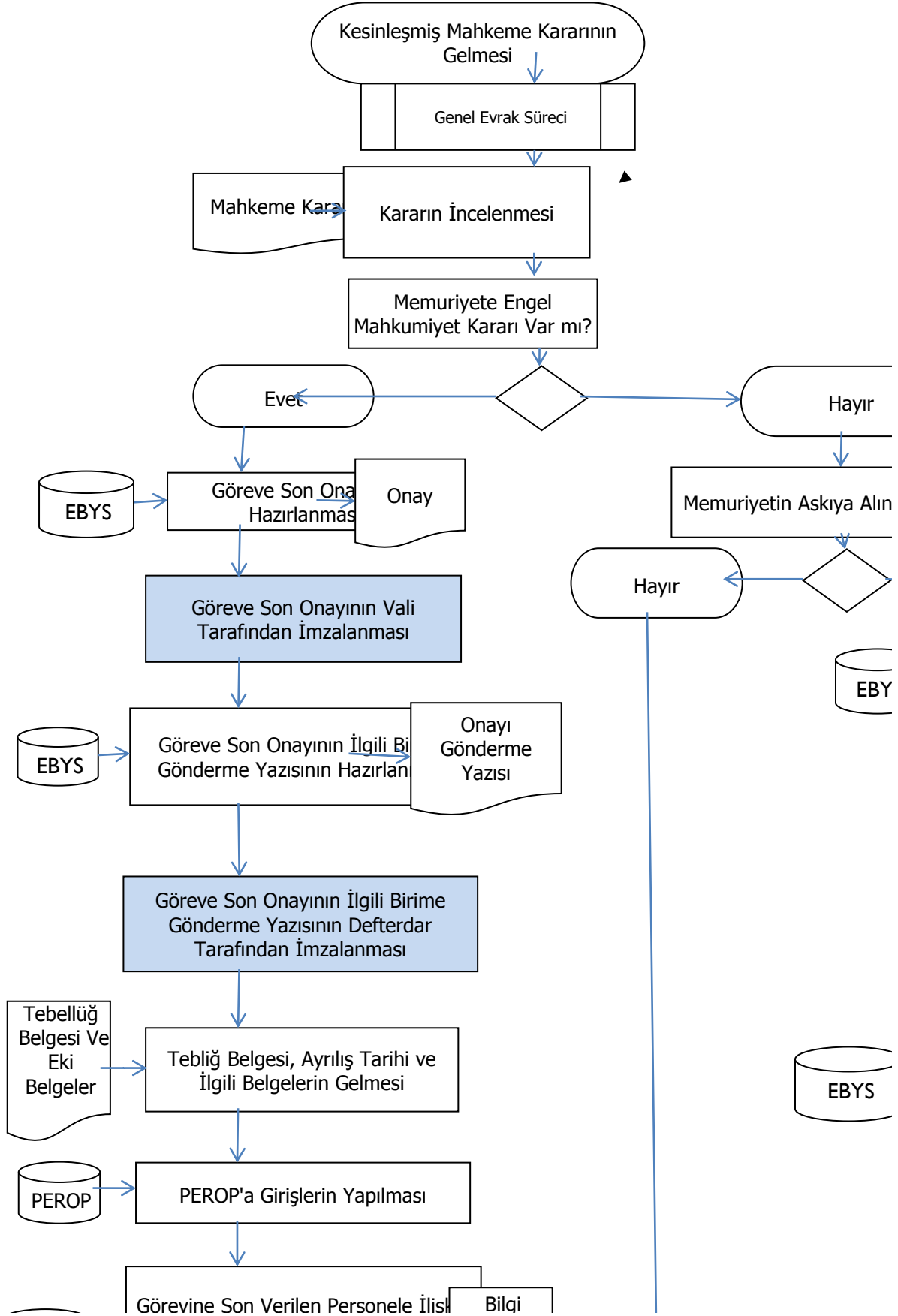

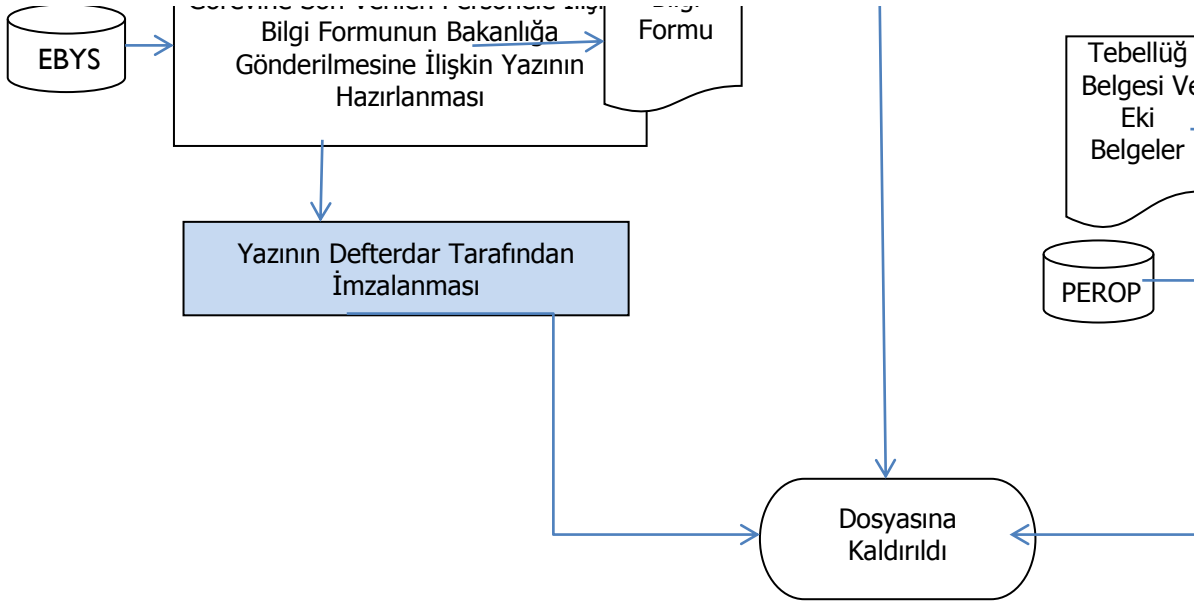

Hazırlayan	Onaylayan:

ın İşlemler Süreci

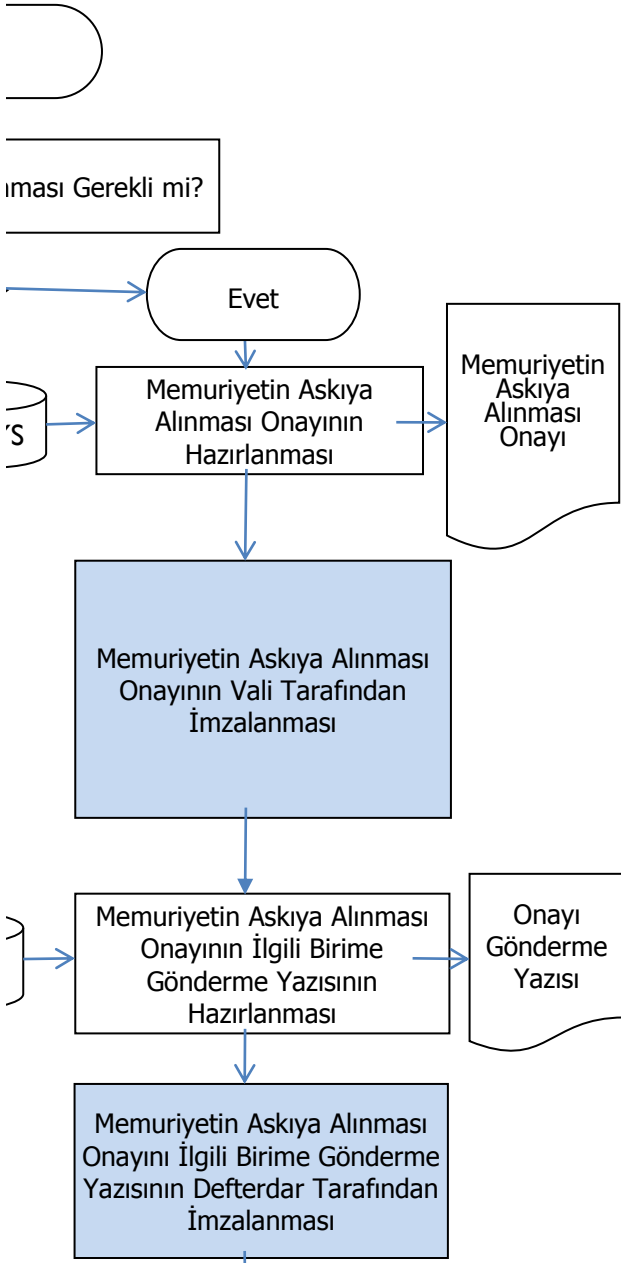

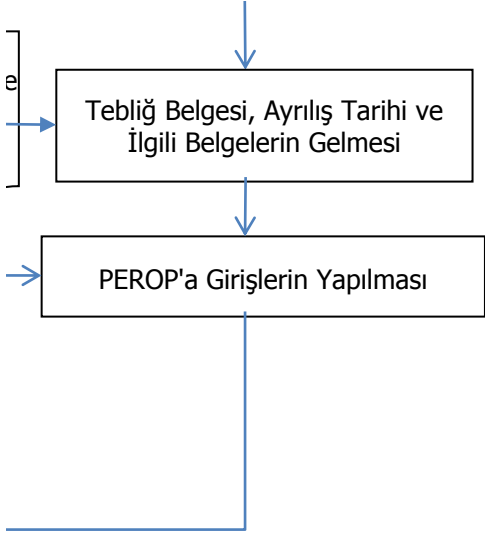

İdari Dava İşlemleri Süreci

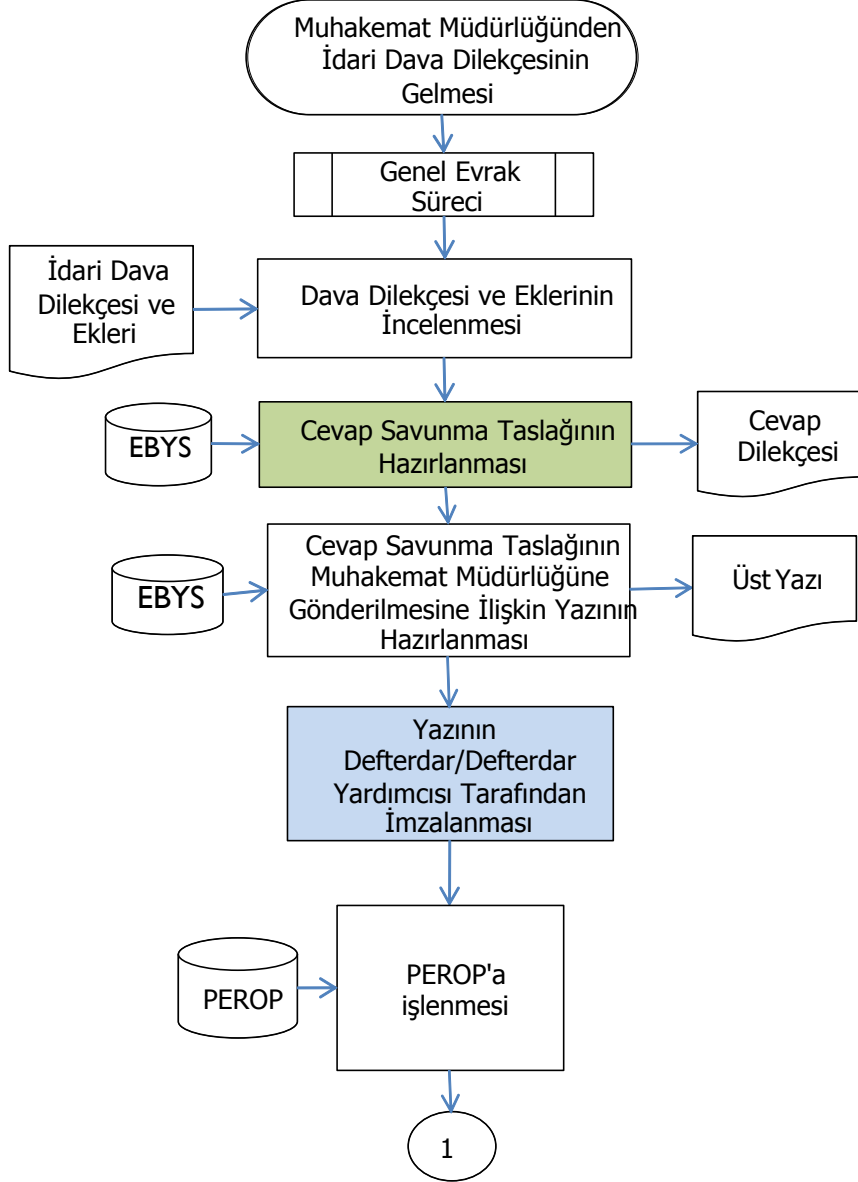

Hazırlayan:

Onaylayan:



İdari Dava İşlemleri Süreci

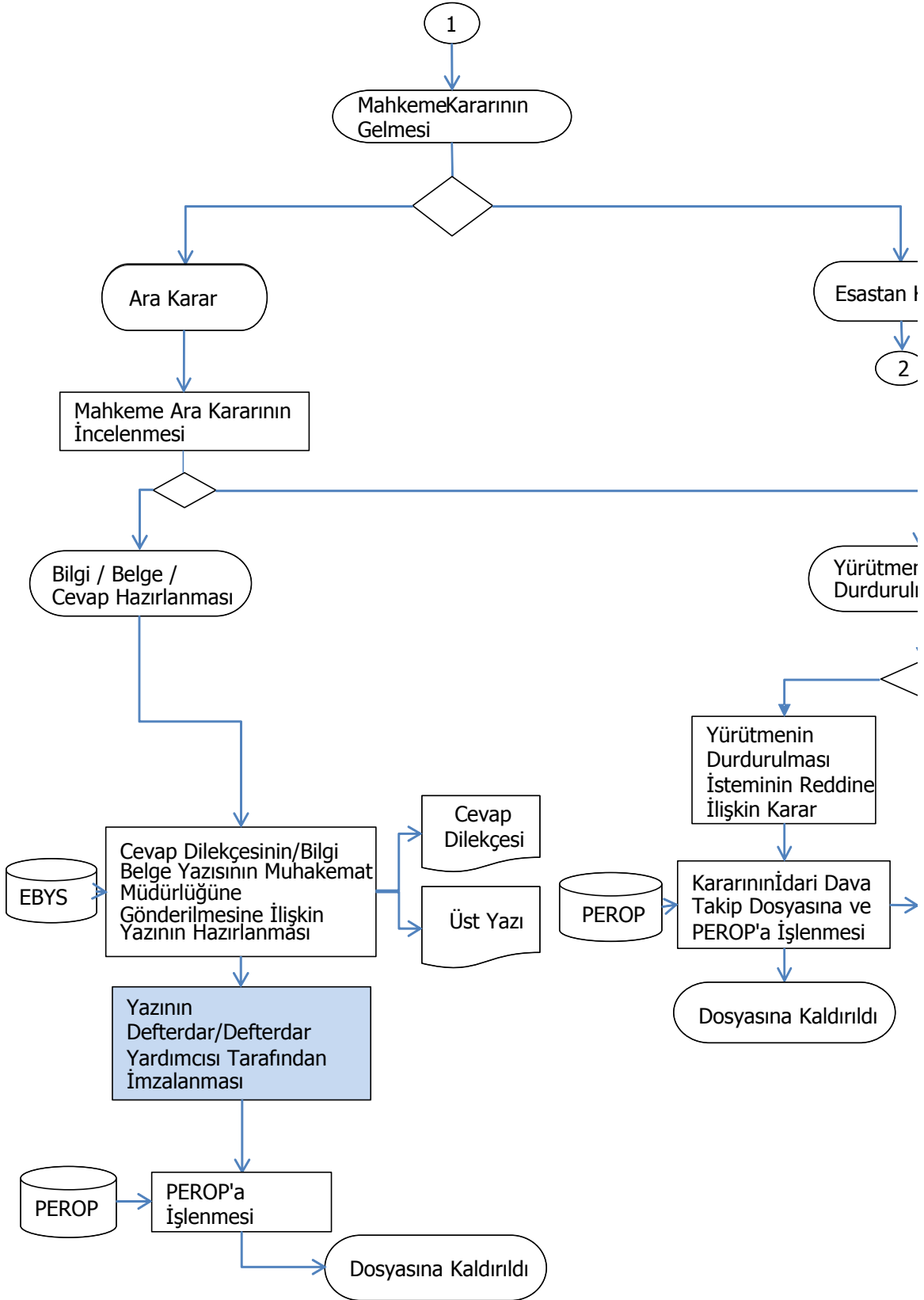

Hazırlayan:

Onaylayan:

Karar

)



nin
masKararı



Yürütmenin
Durdurulması
İsteminin
Kabulüne
İlişkin Kararı

3

4



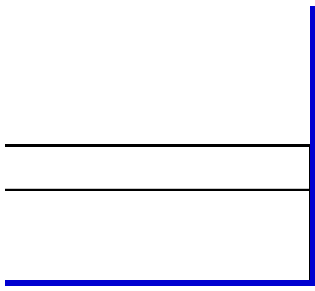

İdari Dava İşlemleri Süreci

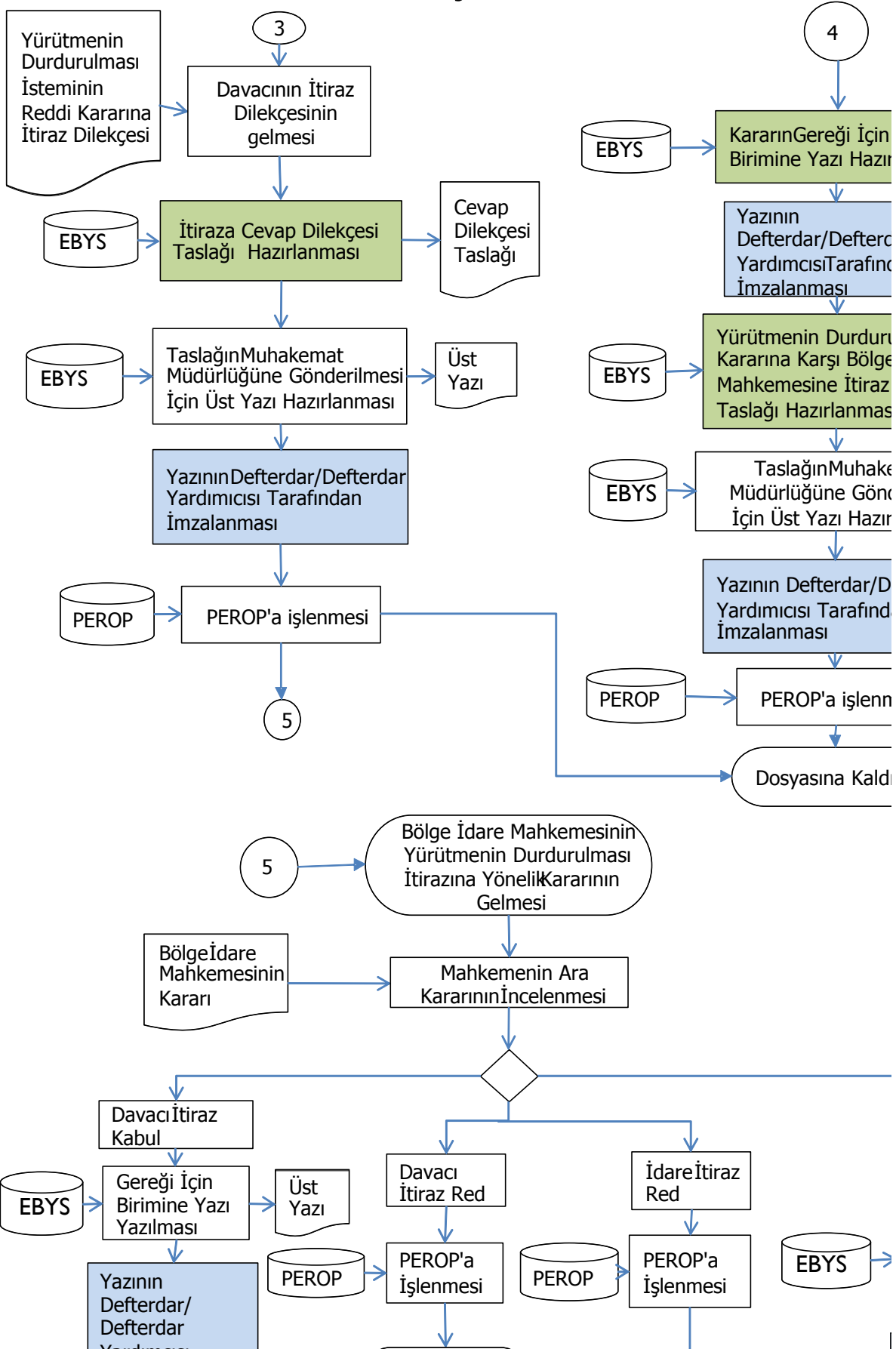

Yardımcısı
Tarafından
İmzalanması

6

Dosyasına
Kaldırıldı



Hazırlayan:

Onaylayan:

--

--

rlanması → Yazı

dar
dan

ulması
e İdare
Dilekçe
si → Cevap
Dilekçesi
Taslağı

emat
derilmesi
lanması → Üst
Yazı

efterdar
an

nesi → 5

ırıldı

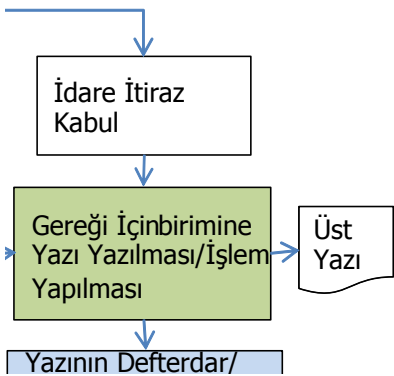

Defterdar Yardımcısı
Tarafından
İmzalanması

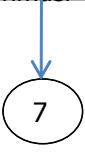

İdari Dava İşlemleri Süreci

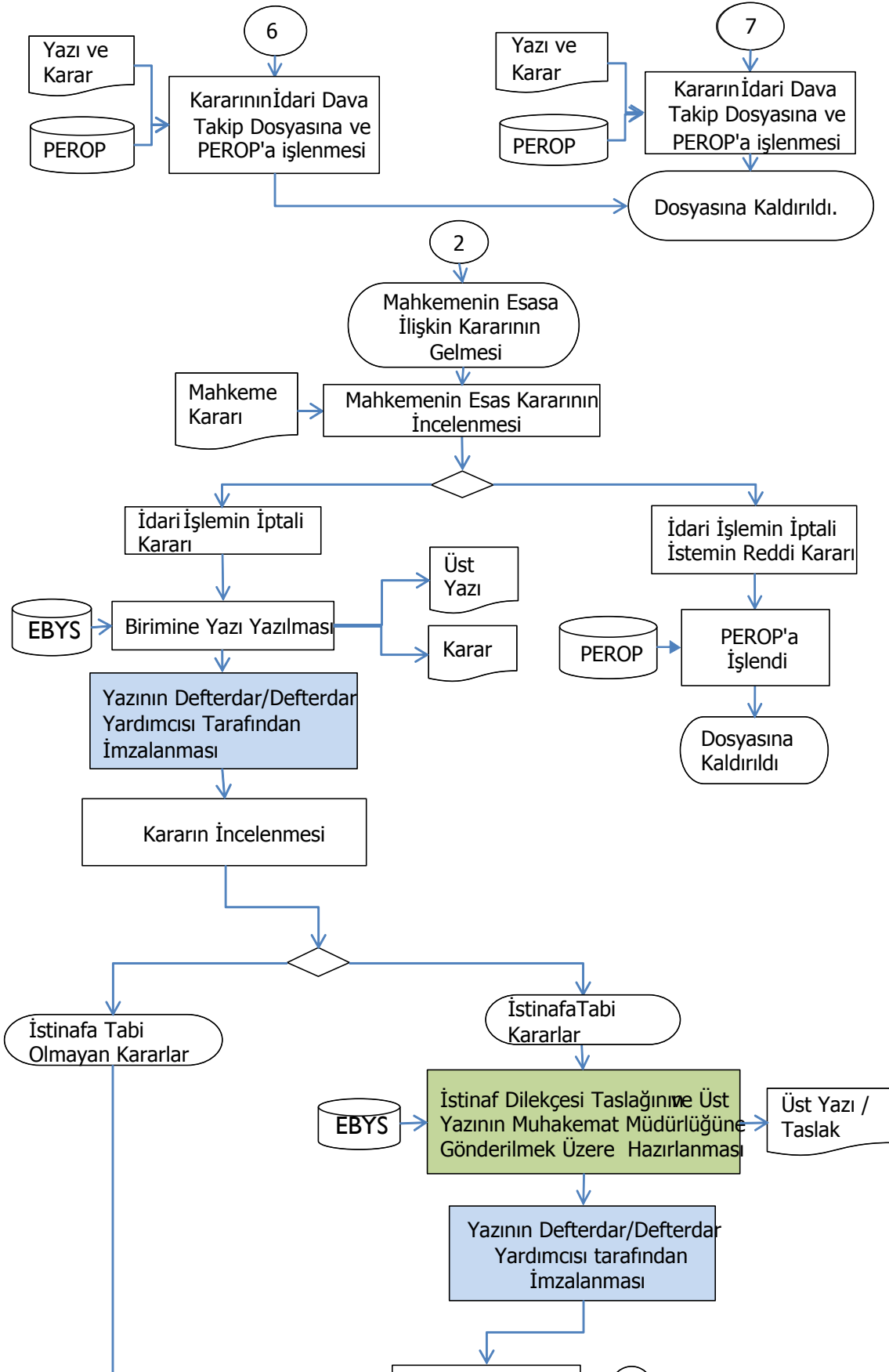

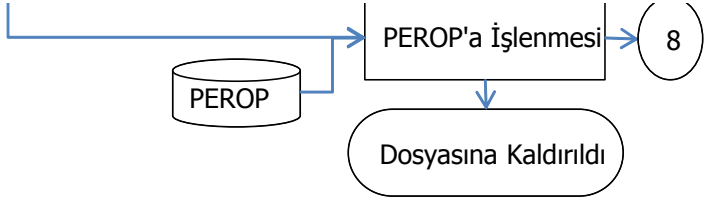

Hazırlayan:

Onaylayan:

--

--



1

İdari Dava İşlemleri Süreci

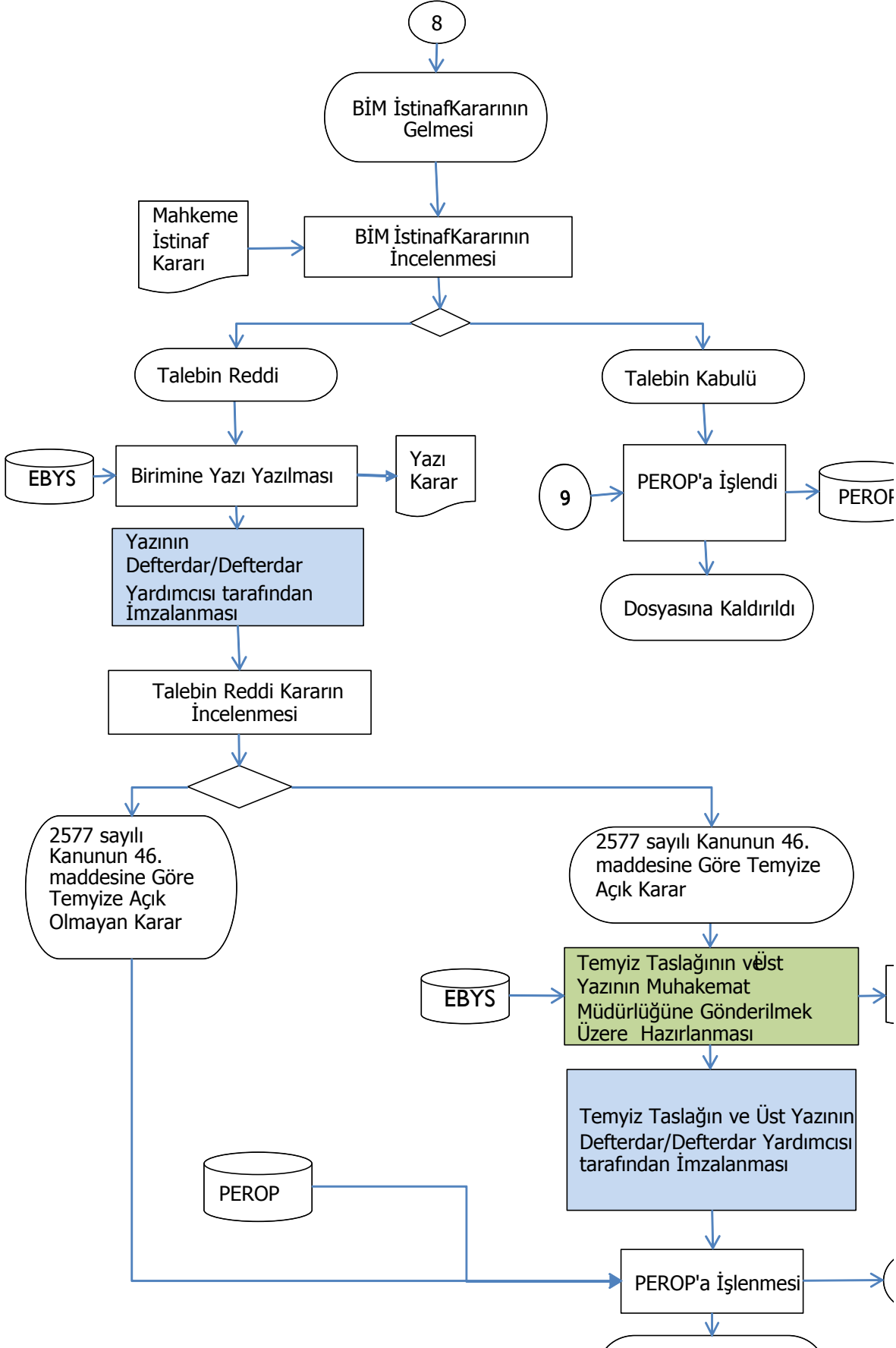

(Dosyasına Kaldırıldı)

Hazırlayan:

Onaylayan:

3

Üst Yazı
Taslak

10

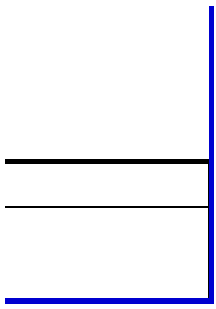

BURDUR Defterdarlığı
Personel Müdürlüğü
İdari Dava İşlemleri Süreci

9

Davacının Temyiz Dilekçesinin Gelmesi

Temyiz Dilekçesi

Davacının Temyiz Dilekçesi İncelenmesi

EBYS

Temyize Cevap Dilekçesi Taslağı Hazırlanması

Taslak

EBYS

Taslağın Muhakemat Müdürlüğüne Gönderilmesi İçin Üst Yazı Hazırlanması

Üst Yazı

Yazının Defterdar/Defterdar Yardımcısı Tarafından İmzalanması

PEROP

PEROP'a İşlenmesi

Dosyasına Kaldırıldı

10

Danıştay Kararının Gelmesi

Danıştay Kararı

Danıştay Kararının İncelenmesi

Bölge İdare Mahkemesi Kararının Onanması ile Temyizin Reddi

Bölge İdare Mahkemesi Kararının Kısmen Onanması/Kısmen Bozulması

Bölge İdare Mahkemesi Kararının Reddile Te Kabulü

EBYS

Kararın Birimine Gönderilme Yazısının Yazılması

EBYS

Kararın Birimine Gönderilme Yazısının Yazılması

Yazının Defterdar/Defterdar Yardımcısına Tarafından İmzalanması

Yazı

EBYS

Yazının Defterdar/D Yardımcısına Tarafından İmzalanması

PEROP

PEROP'a İşlenmesi

PERKOP

Hazırlayan:

Onaylayan:

emesi
emyizin

on

lefterdar
dan

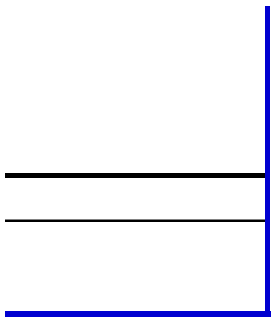

4483 Sayılı Kanun Kapsamında Soruşturma

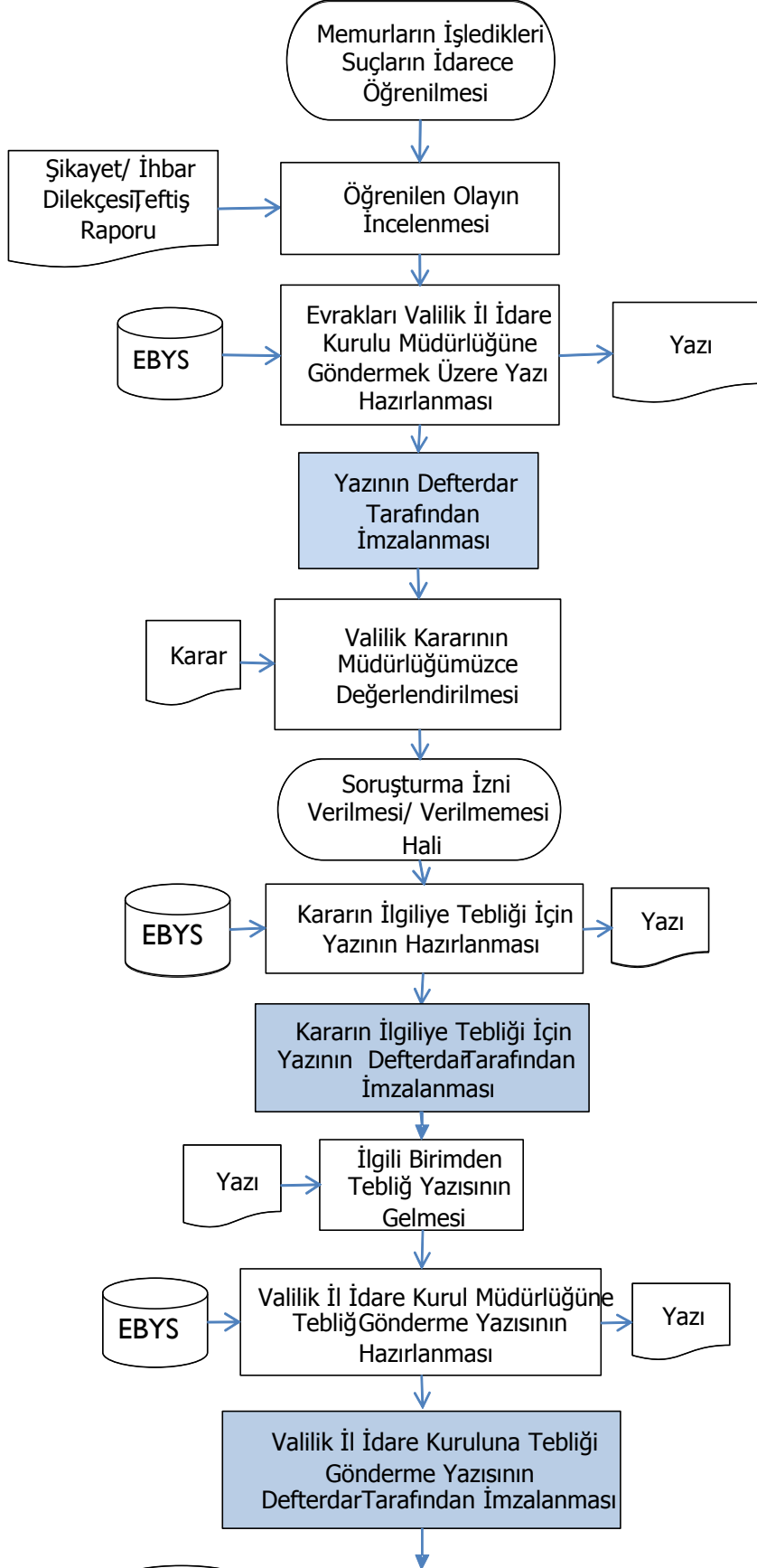

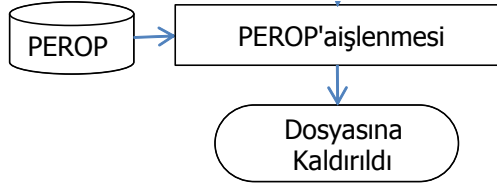

Hazırlayan:

Onaylayan:

a Süreci

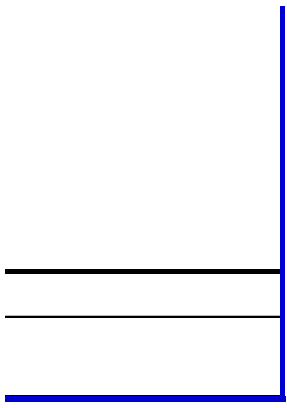

BURDUR Defterdarlığı Personel Müdürlüğü

Disiplin Cezalarına İtiraz İşlem Süreci

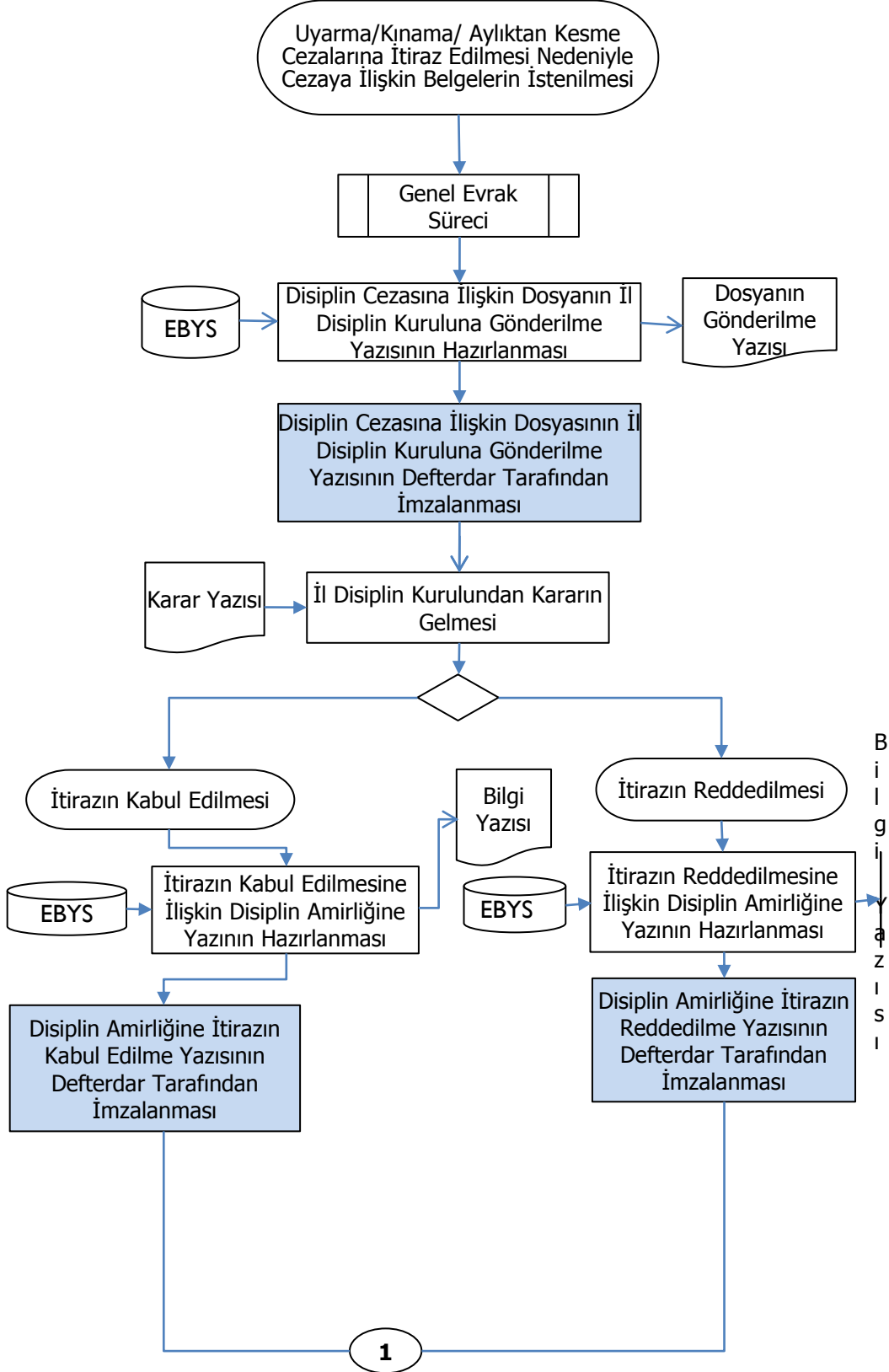

Hazırlayan:

Onaylayan:

--	--



BURDUR Defterdarlığı Personel Müdürlüğü

Disiplin Cezalarına İtiraz İşlem Süreci

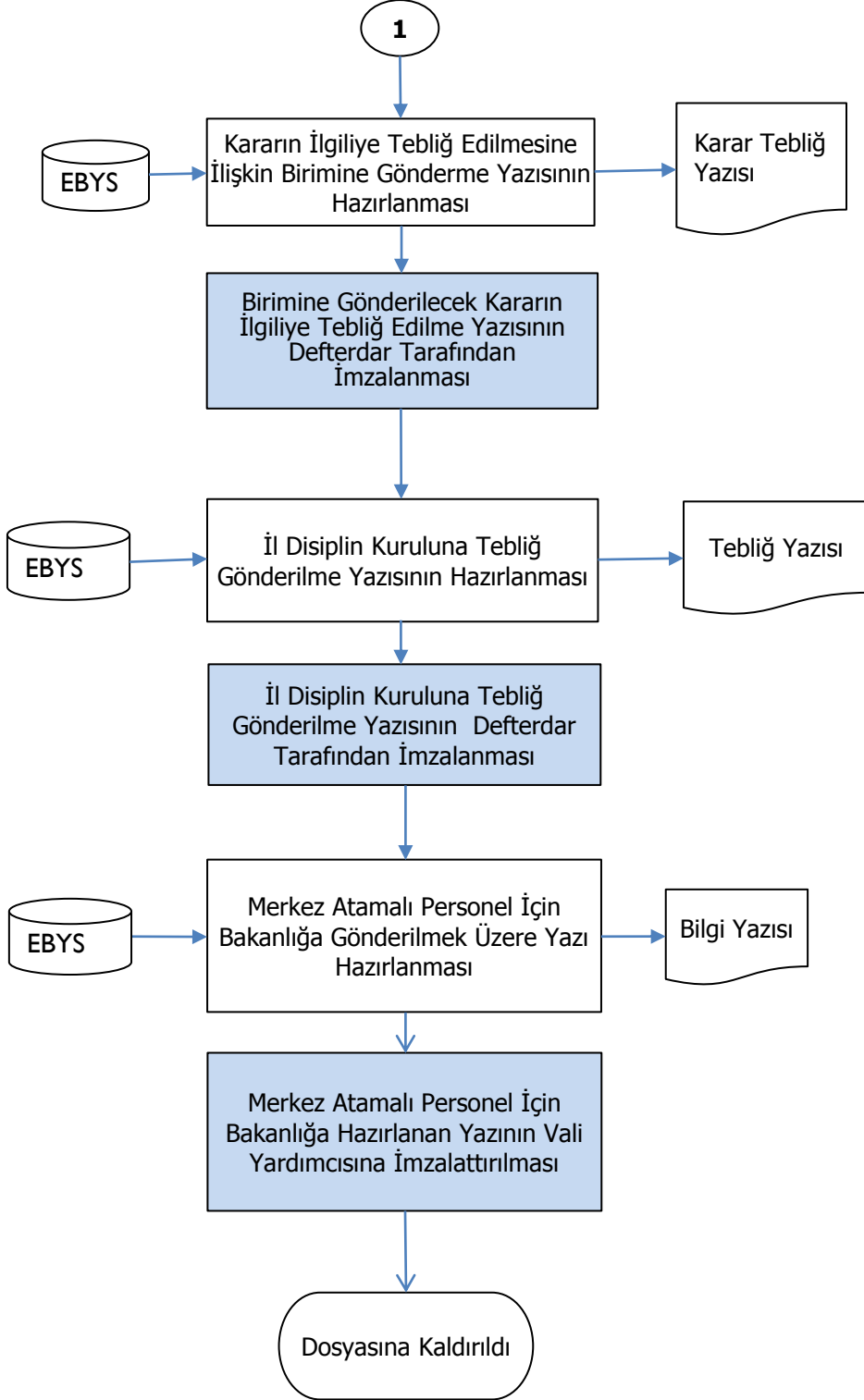

Hazırlayan:	Onaylayan:

BURDUR Defterdarı Personel Müdürlüğü Disiplin İşleri İşlem Sü

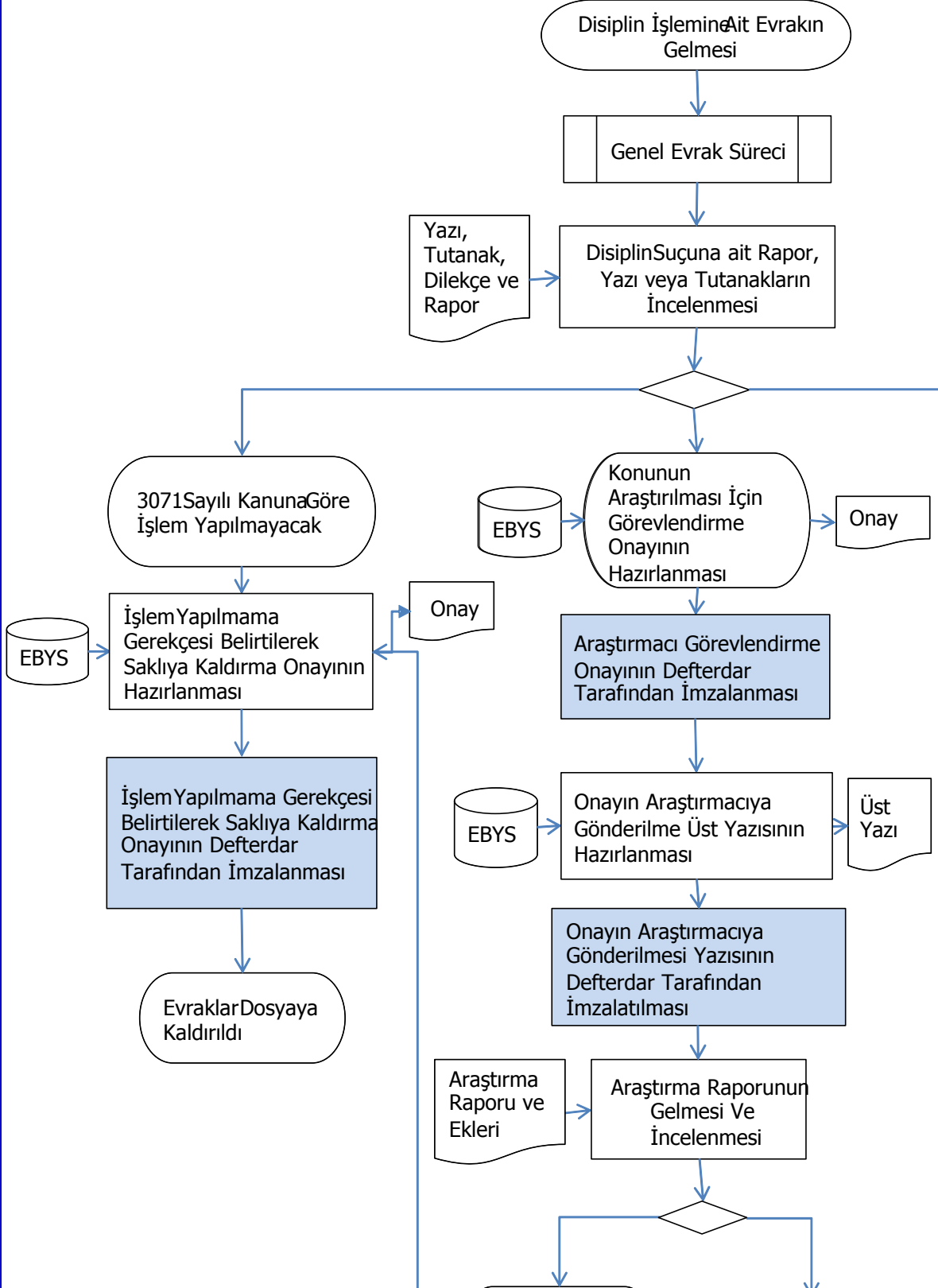

Disiplin
Soruşturmasına
Gerek Yok

Disiplin
Soruşturmasına
Gerek Var

Hazırlayan:

Onaylayan :

liğı
reci

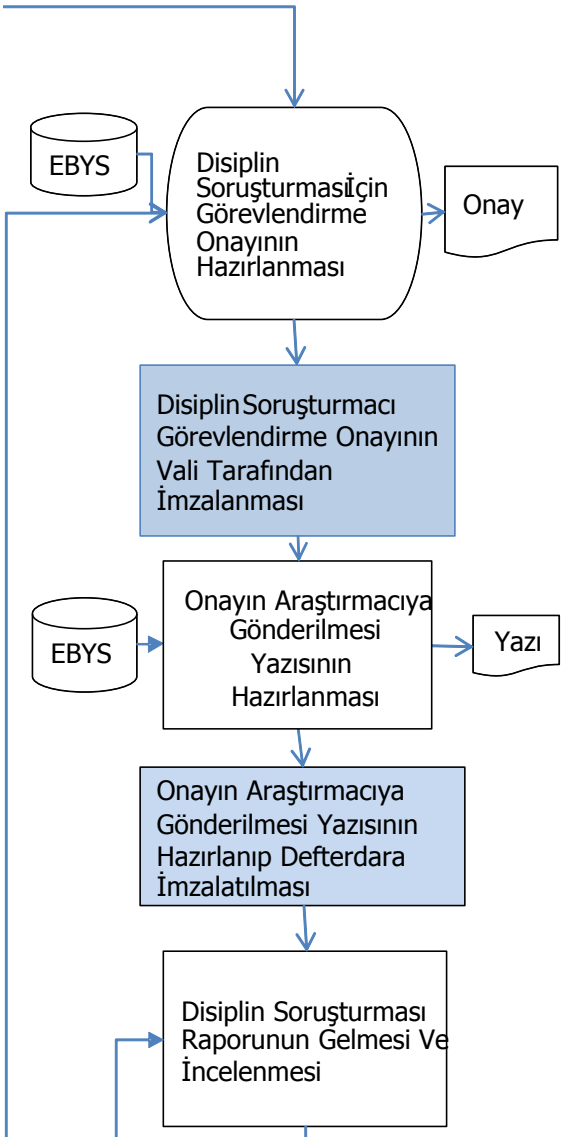

Disiplin
Soruşturma
Raporu ve
Ekleri

1

BURDUR Defterdarlığı Personel Müdürlüğü Disiplin İşleri İşlem Süreci

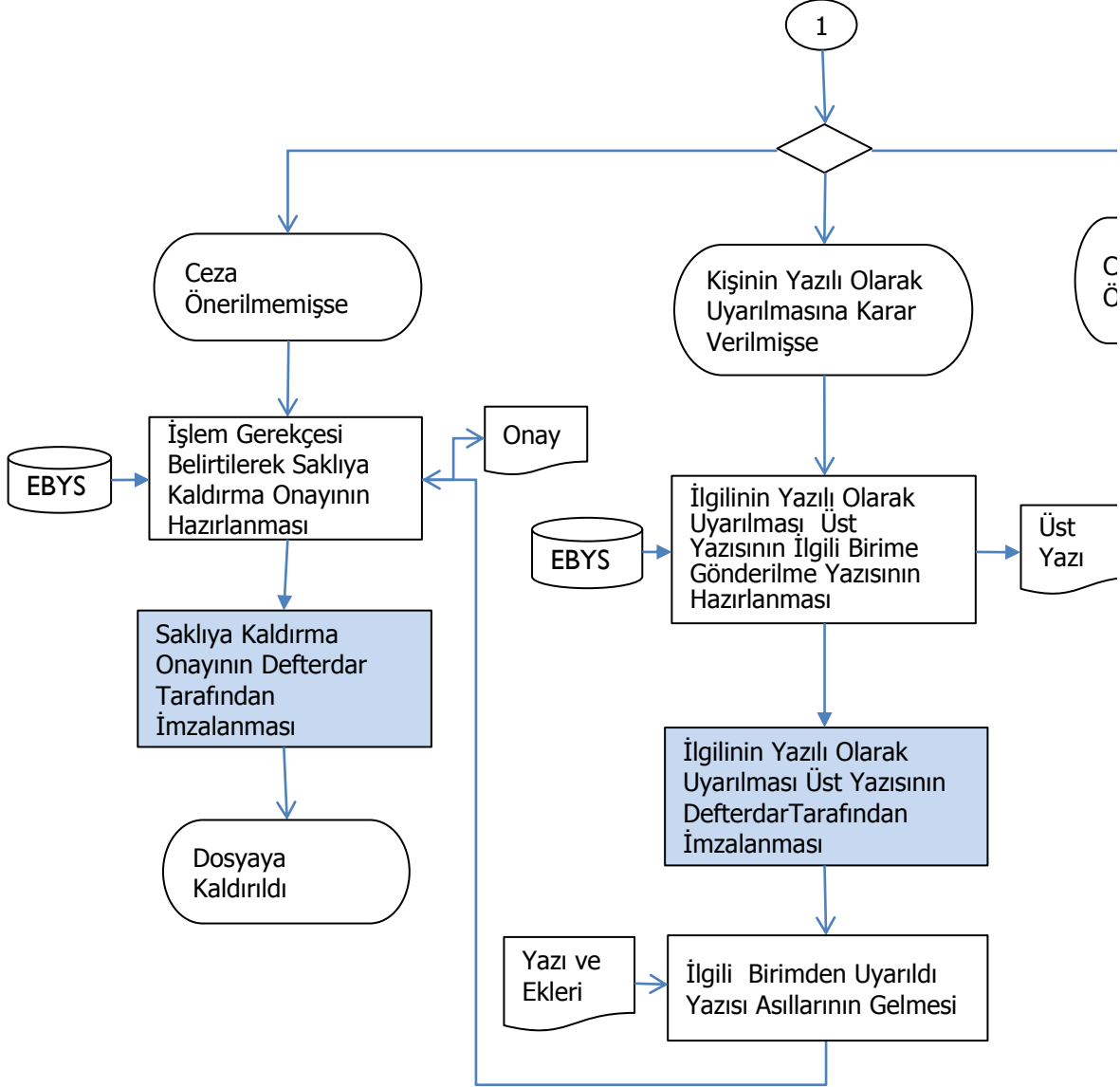

Hazırlayan:

Onaylayan :



i

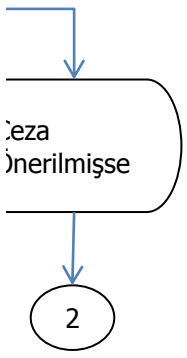

]





BURDUR Defterdarlığı Personel Müdürlüğü Disiplin İşleri İşlem Süreci

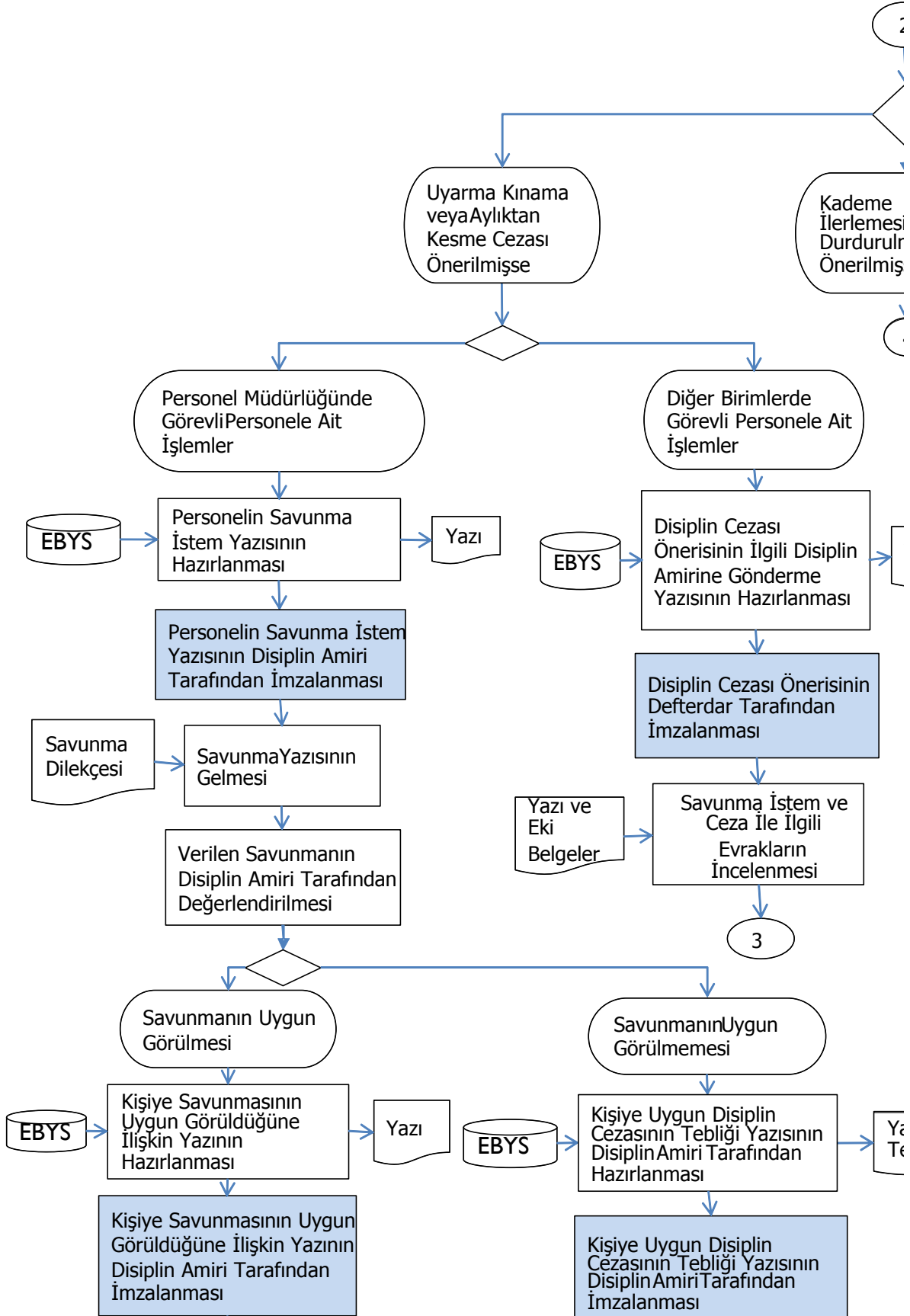

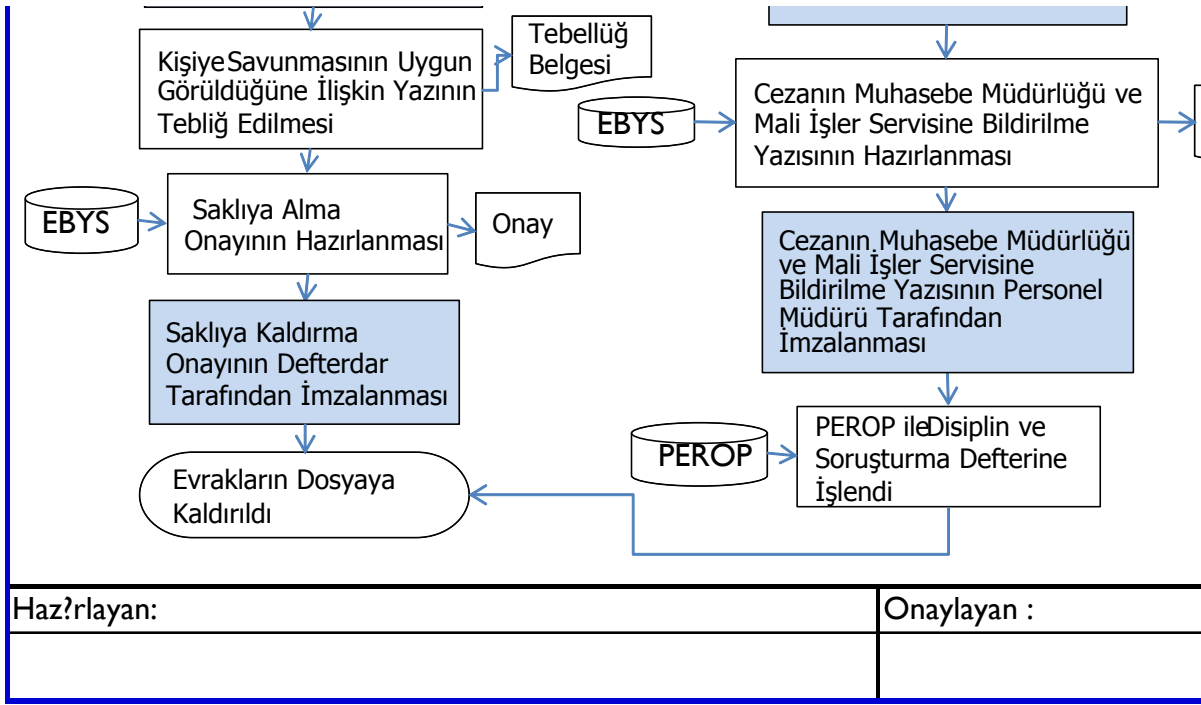

I

ci

2

↓

↓

↓

↓

↓

↓

4

↓

↓

↓

↓

↓

↓

↓

↓

↓

↓

↓

↓

↓

↓

↓

↓

↓

↓

↓

↓

↓

↓

↓

↓

inin
nası Cezası
se

Devlet
Memurluğundan
Çıkarma Cezası
Önerilmişse

5

Yazı

azı/
ebliğat

Yazı

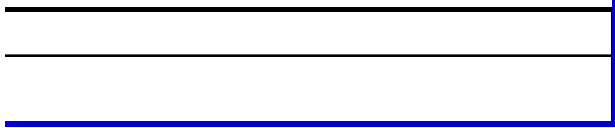

BURDUR Defterdarlığı Personel Müdürlüğü Disiplin İşleri İşlem Süreci

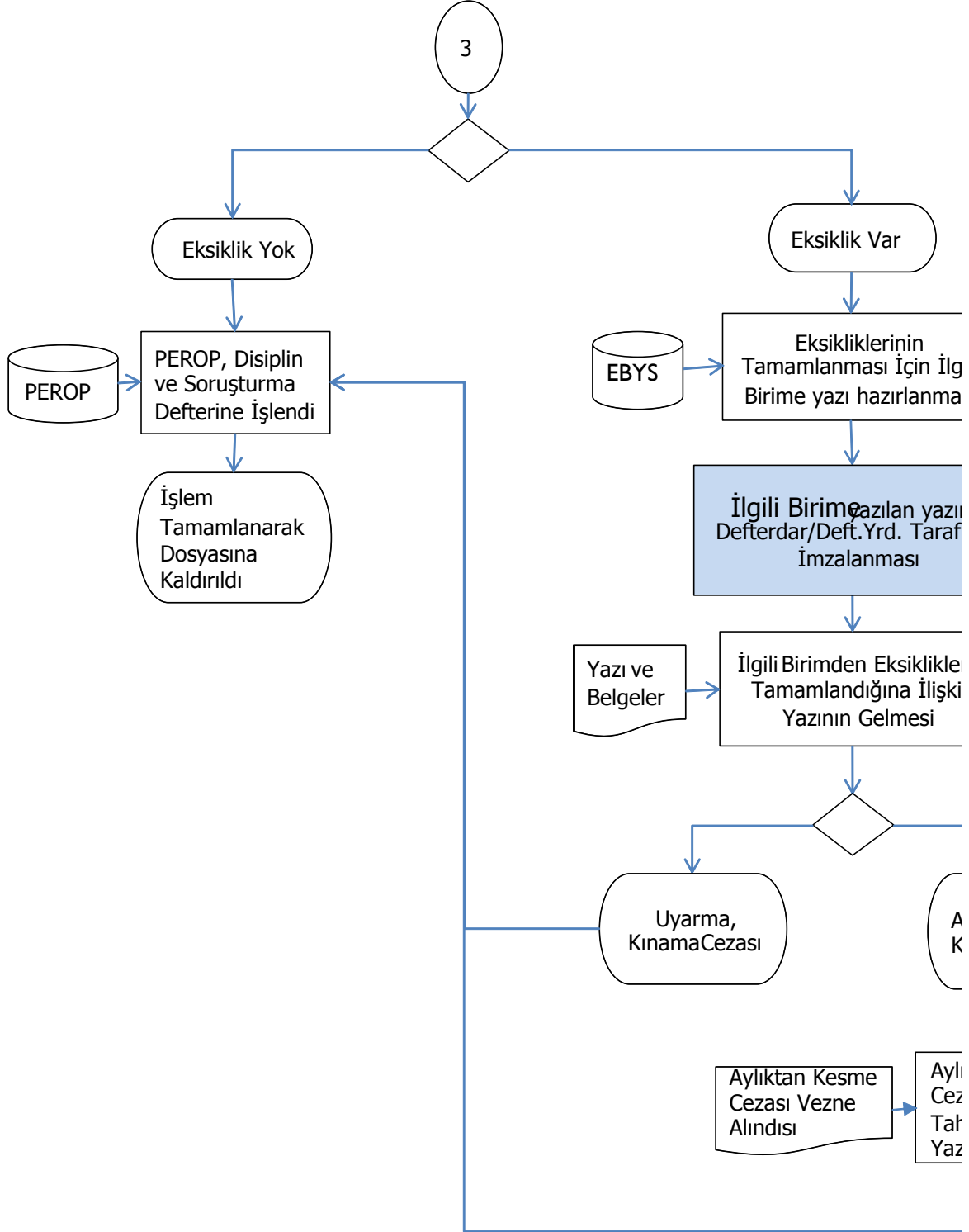

Hazırlayan:

Onaylayan:

--

--

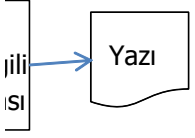

nın
indan

rin
in

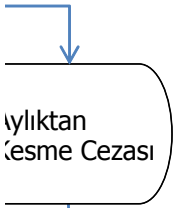

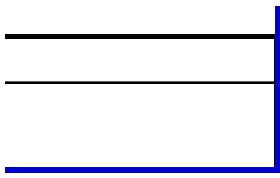

BURDUR Defterdarlığı Personel Müdürlüğü Disiplin İşleri İşlem Süreci

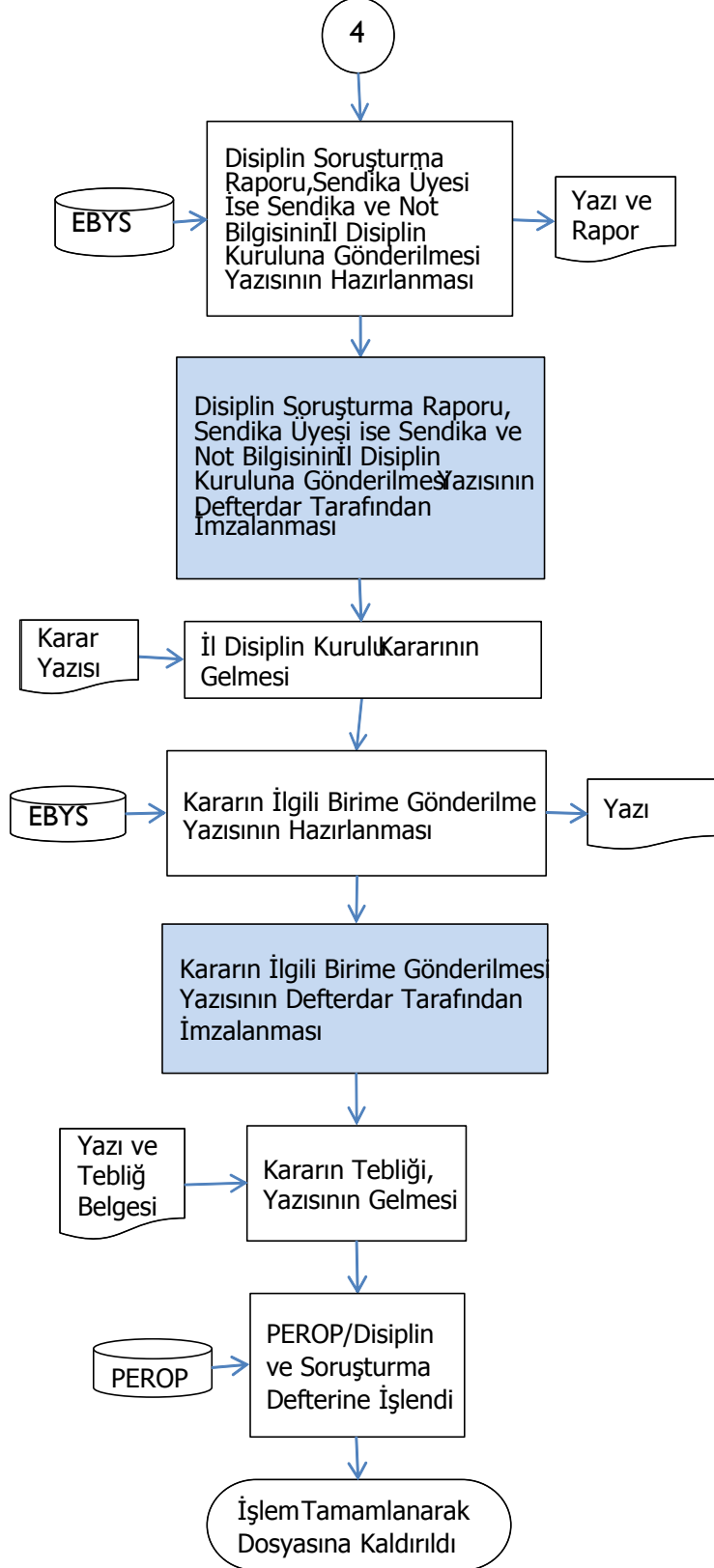

Hazırlayan:	Onaylayan:

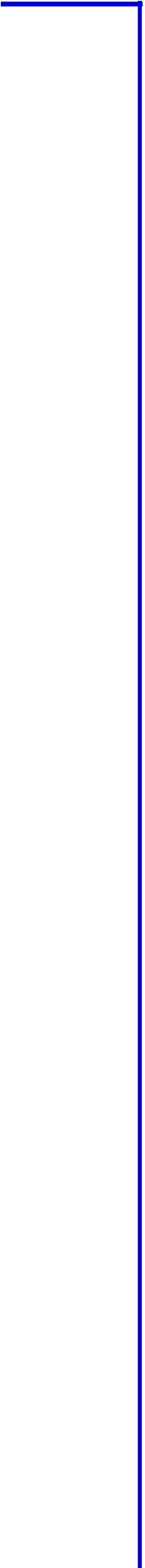

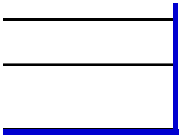

BURDUR Defterdarlığı Personel Müdürlüğü Disiplin İşleri İşlem Süreci

5

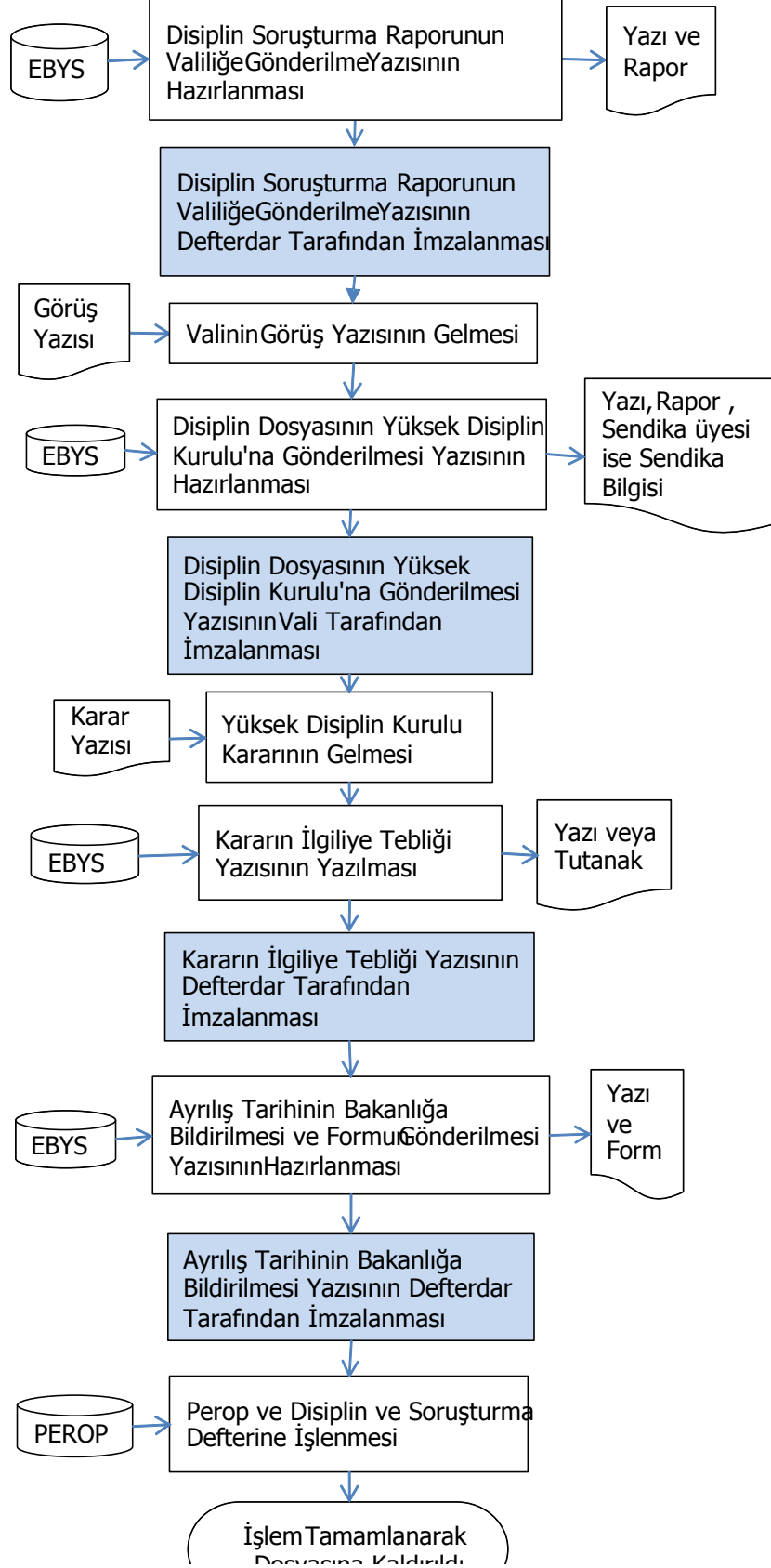

Dosyasına Kaldırıldı

Hazırlayan:

Onaylayan:

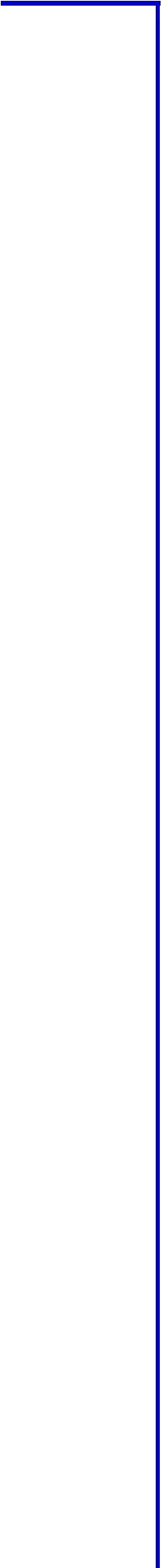

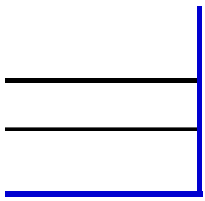

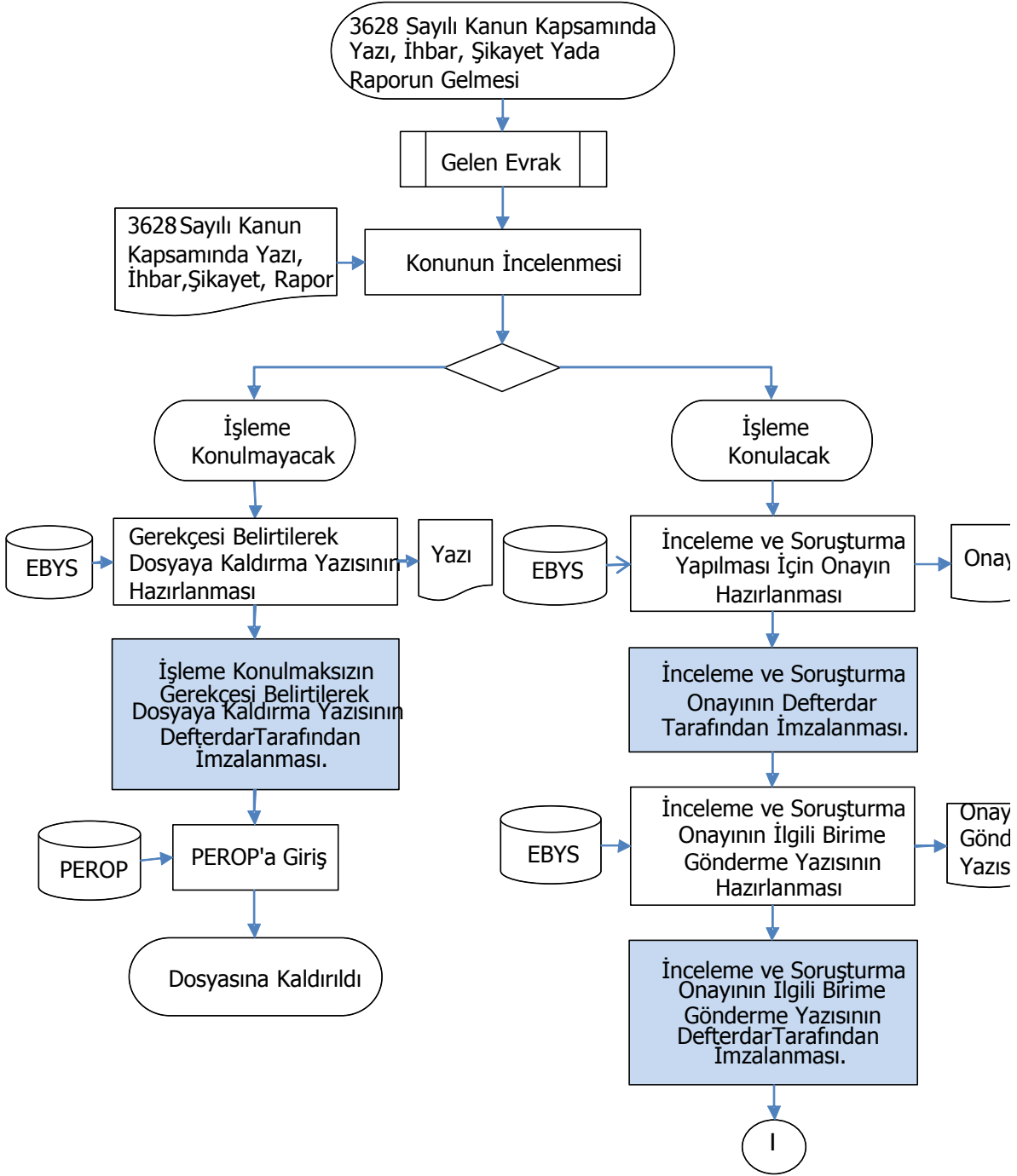

Hazırlayan:

Onaylayan:

y

terme
il

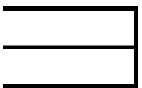

BURDUR Defterdarlığı Personel Müdürlüğü

3628 Sayılı Kanun Gereği Yapılan İşlemler

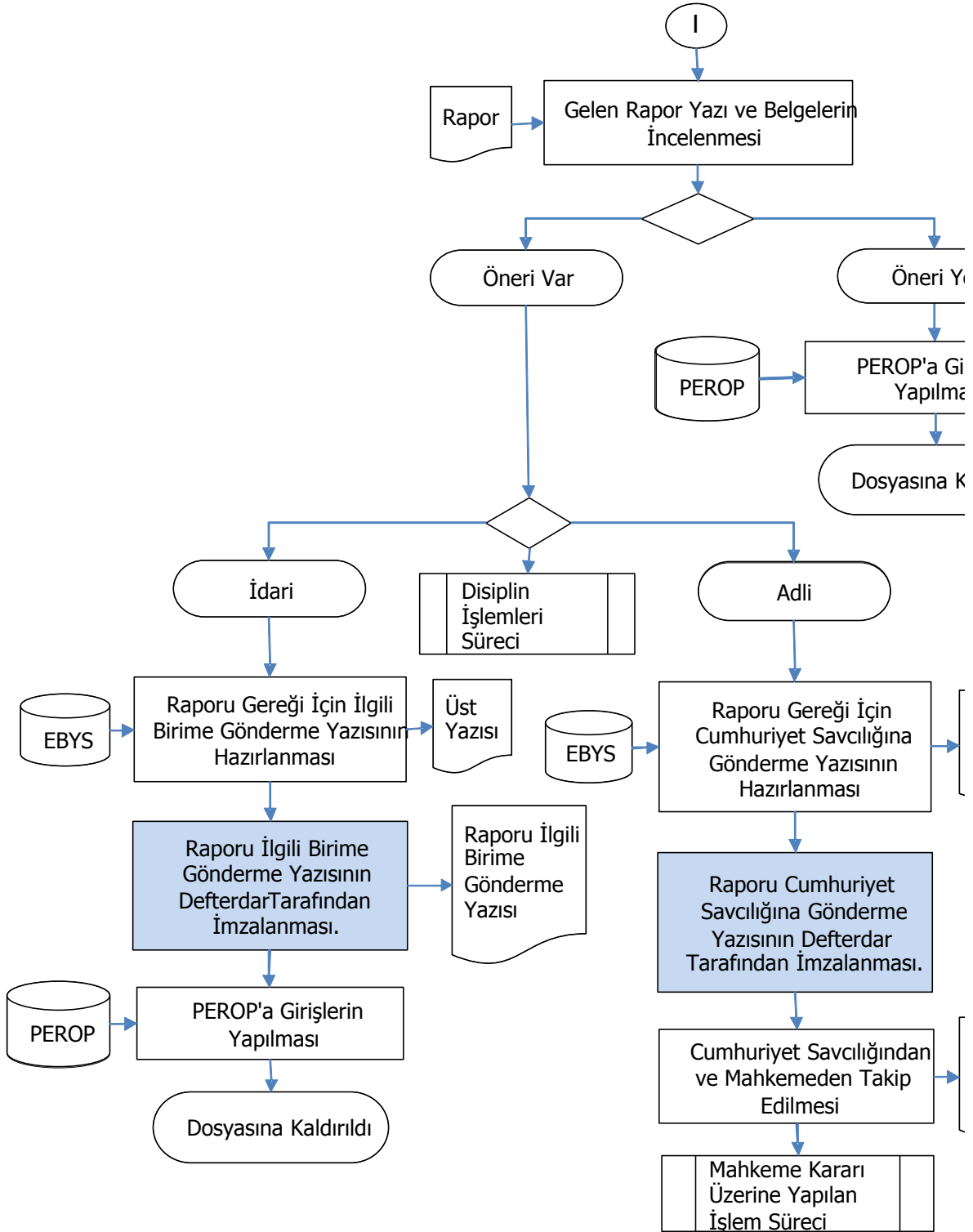

Haz?rlayan:

Onaylayan:

--	--

r Süreci

ok

rişlerin
ası

aldırıldı

Savcılığa
Gönderme
Yazısı

Takip
Yazısı



BURDUR Defterdarlığı Personel Müdürlüğü Malbildirimi İşlemleri Süreci

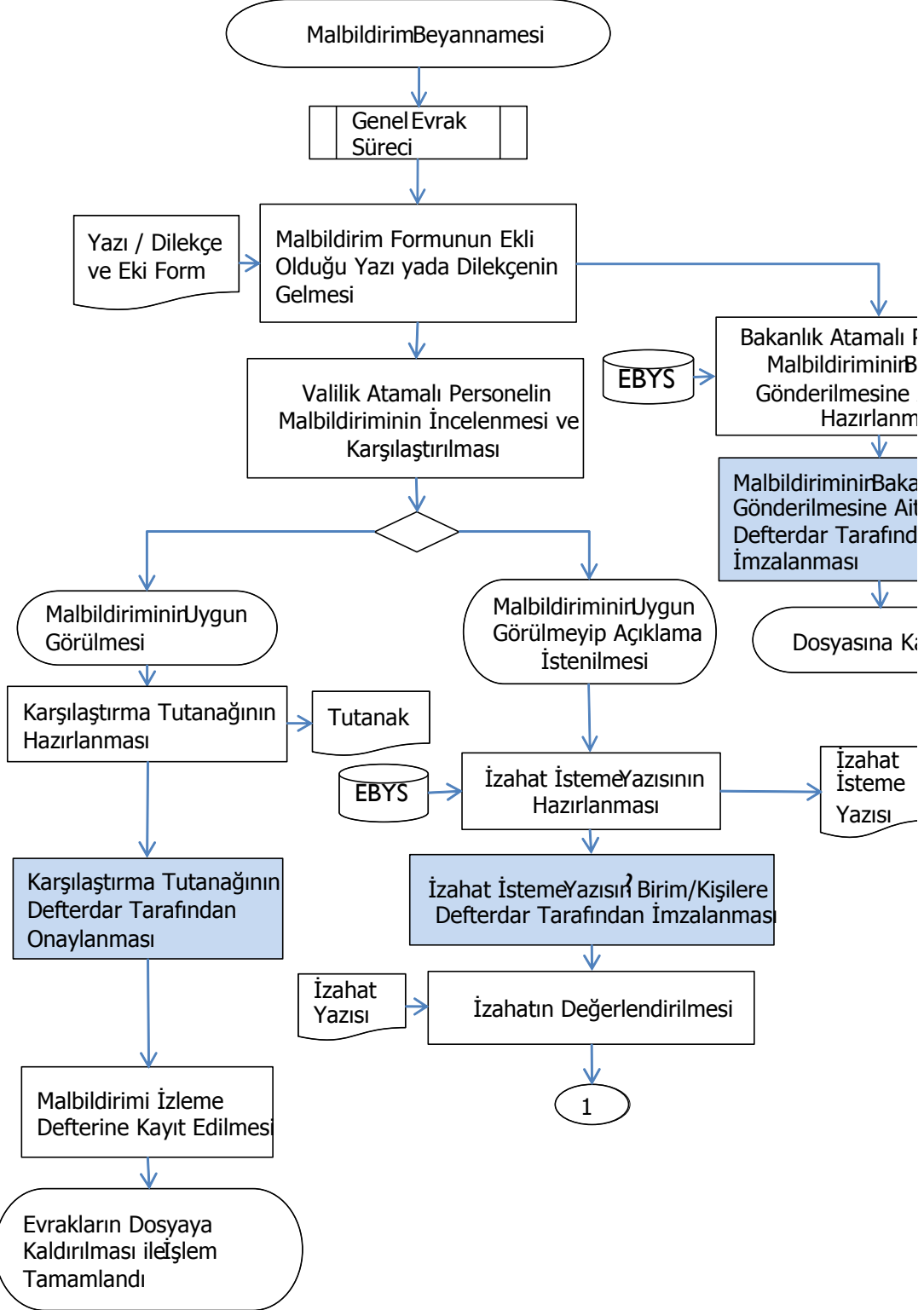



Personele Ait
İstihlaklılığa
Ait Yazının
İstihlaklılığı

Yaz?

İstihlaklılığa
Ait Yazının
İstihlaklılığı

İstihlaklılığı

]

_____ |

BURDUR Defterdarlığı
Personel Müdürlüğü
Malbildirimi İşlemleri Süreci

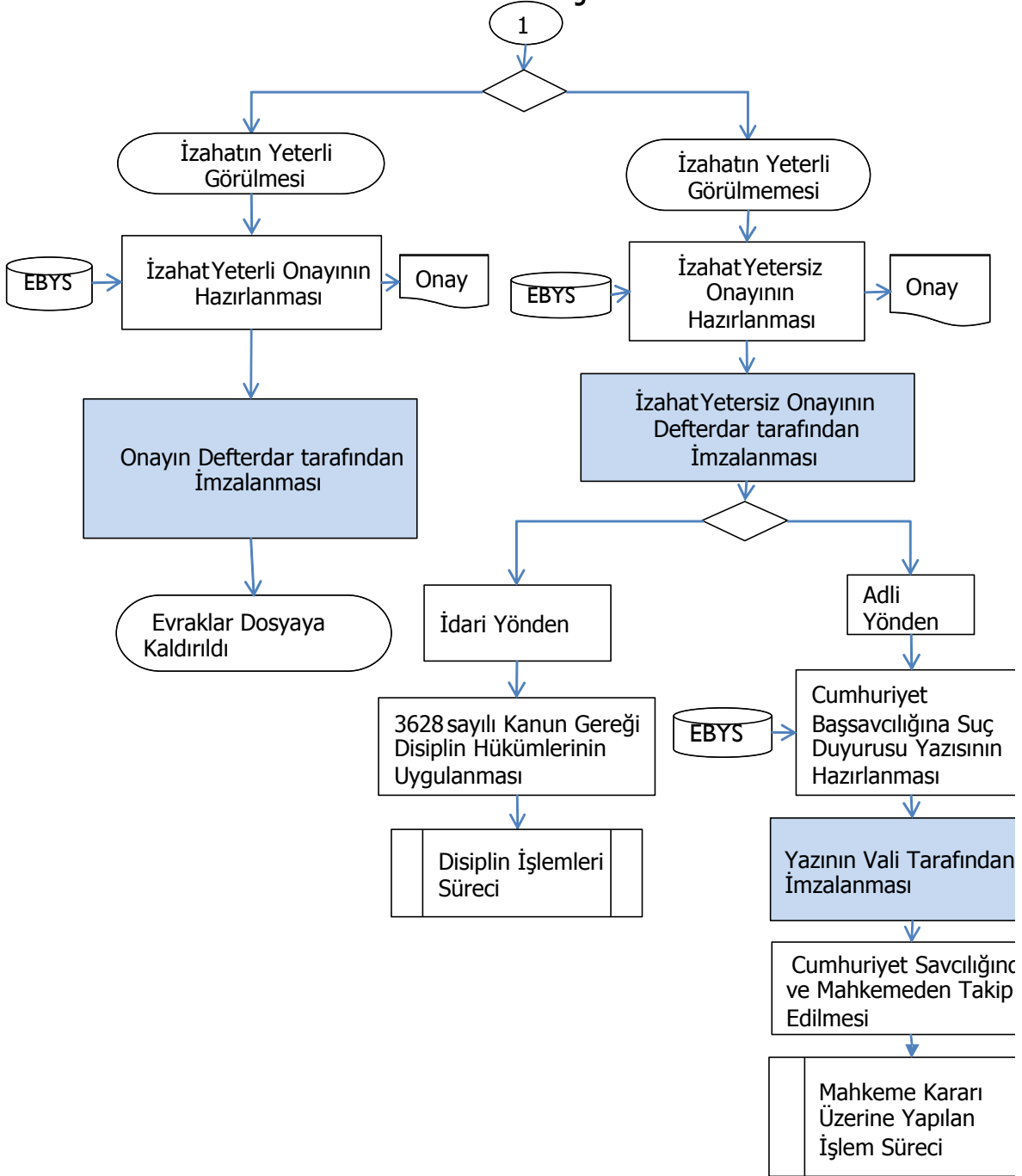

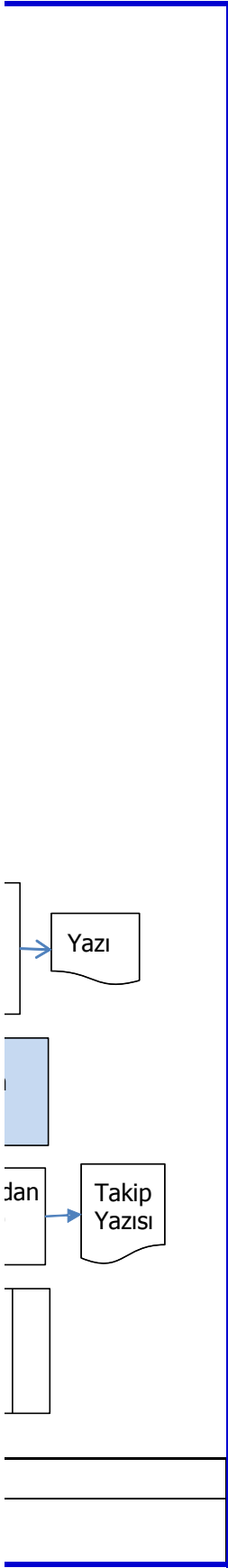

BURDUR Defterdarlığı Personel Müdürlüğü

Araç Görevlendirilmesi İşlem Süreci

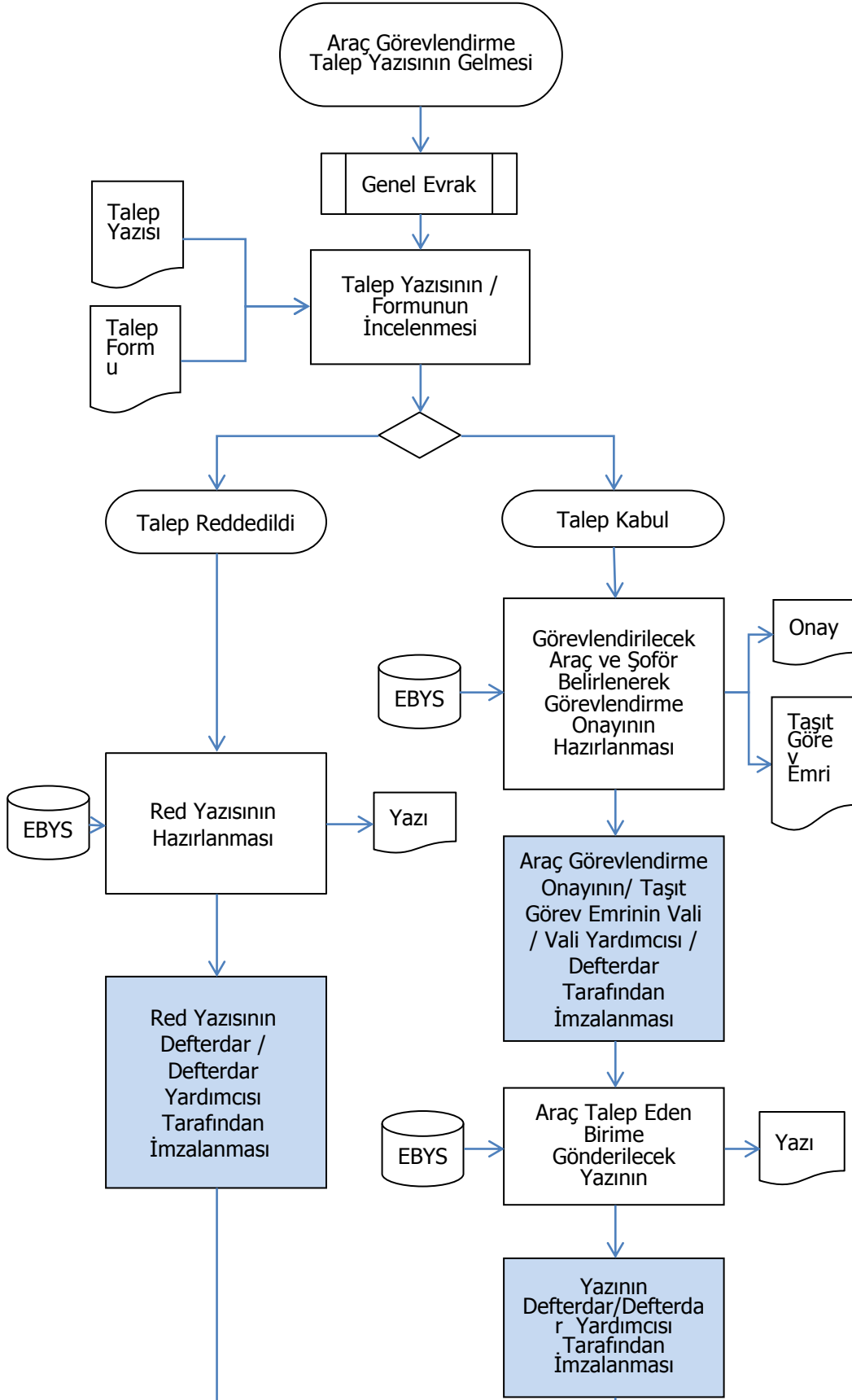



Hazırlayan:	Onaylayan:

Açık İhale Usulüyle Mal ve Hizmet Alım İşlem Süreci

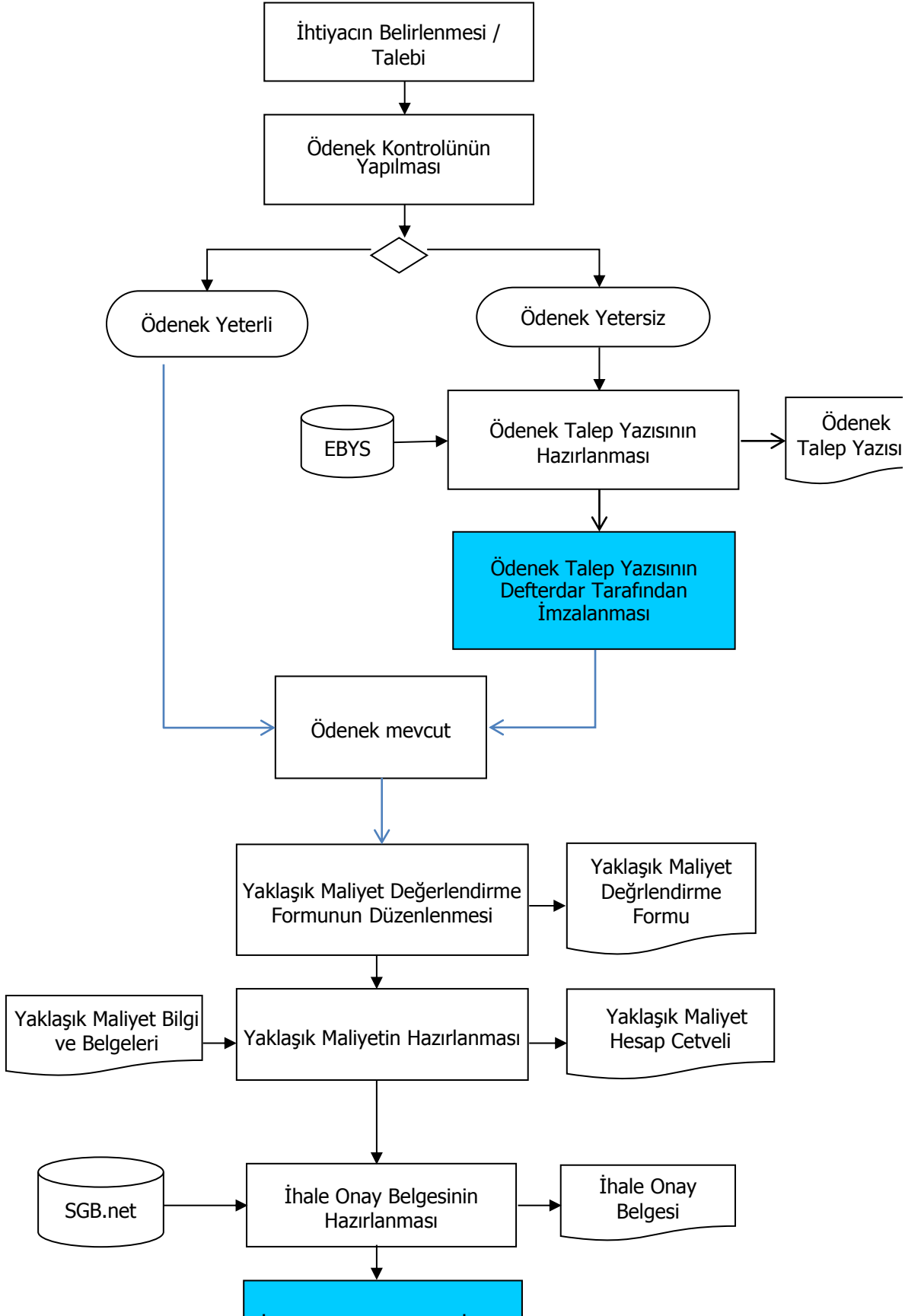

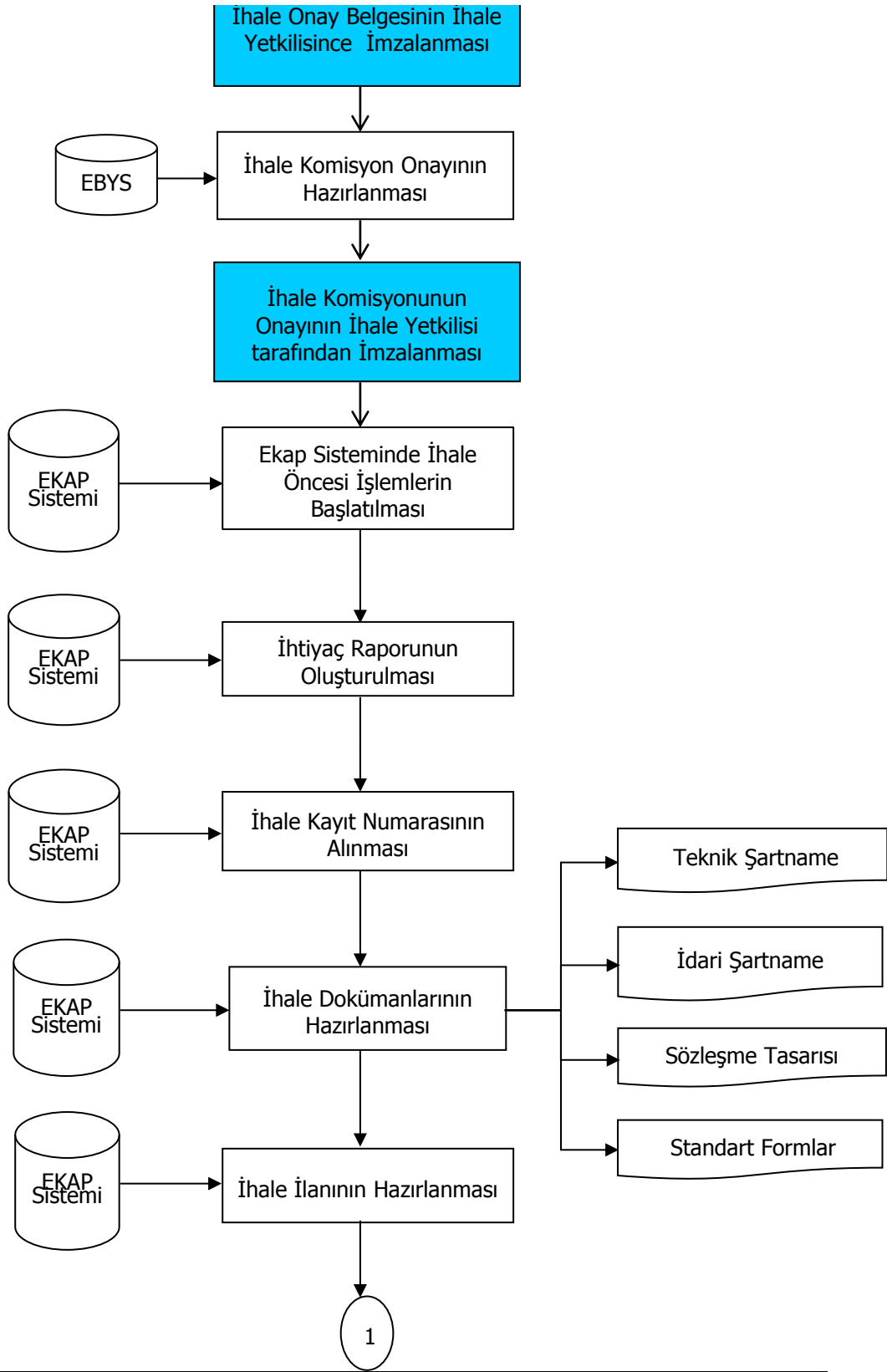

Hazırlayan:	Onaylayan:

i

]

Açık İhale Usulüyle Mal ve Hizmet A

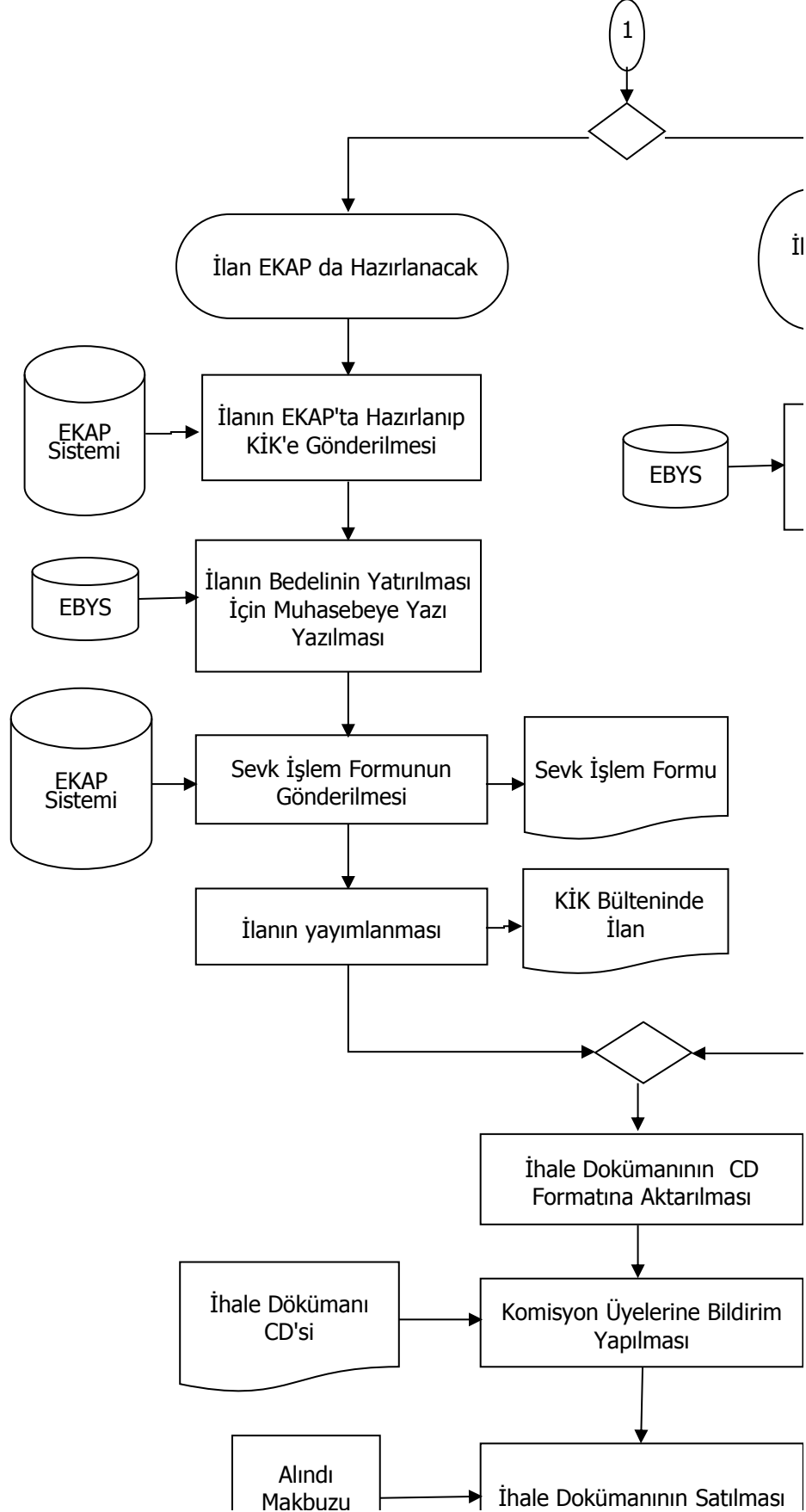

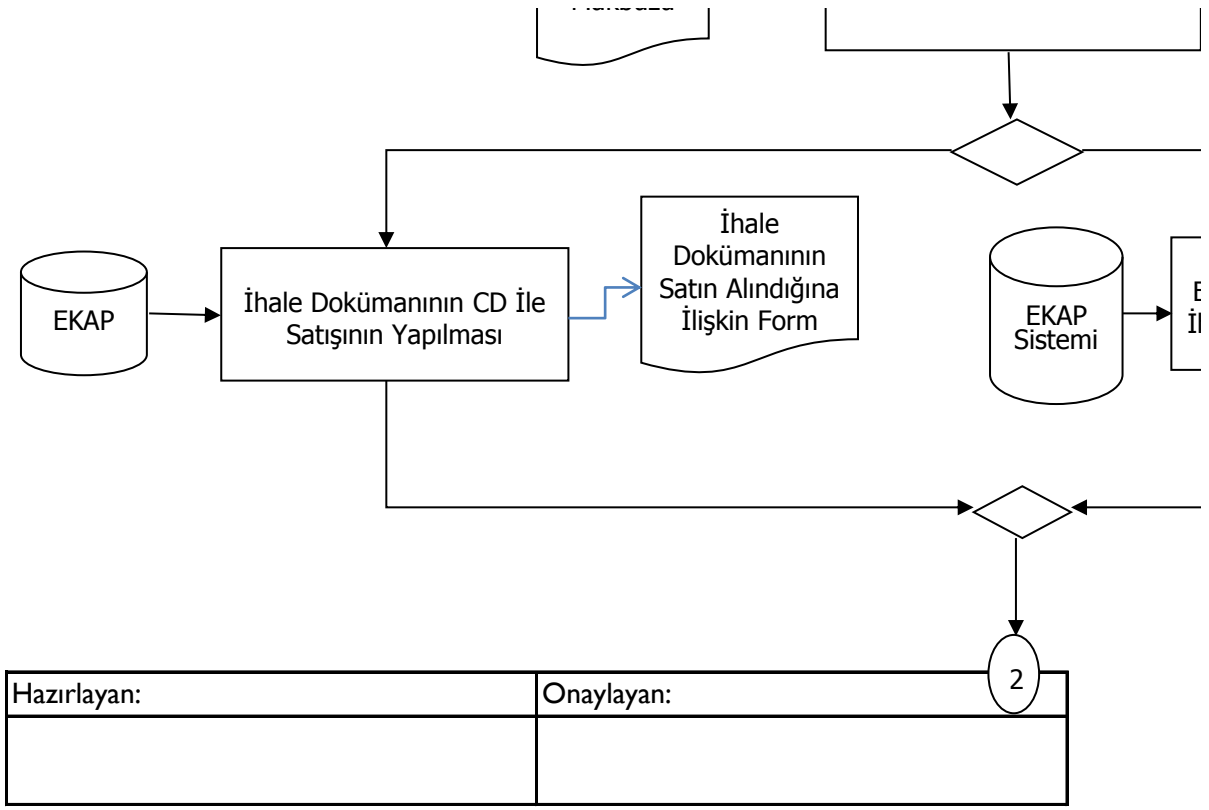

Hazırlayan:	Onaylayan:	2

İlim İşlem Süreci

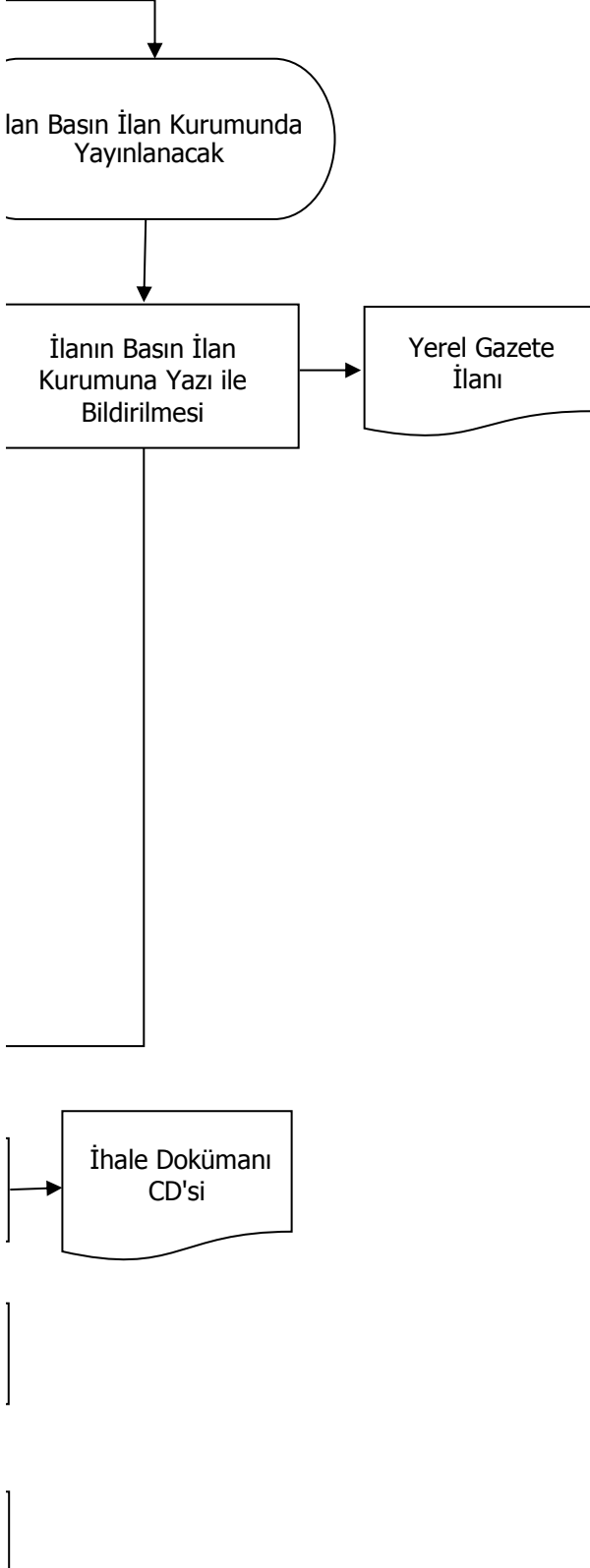

|

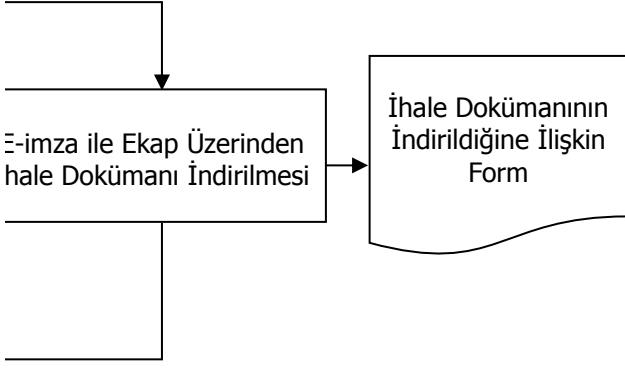

Açık İhale Usulüyle Mal ve Hizmet Alım İşlem

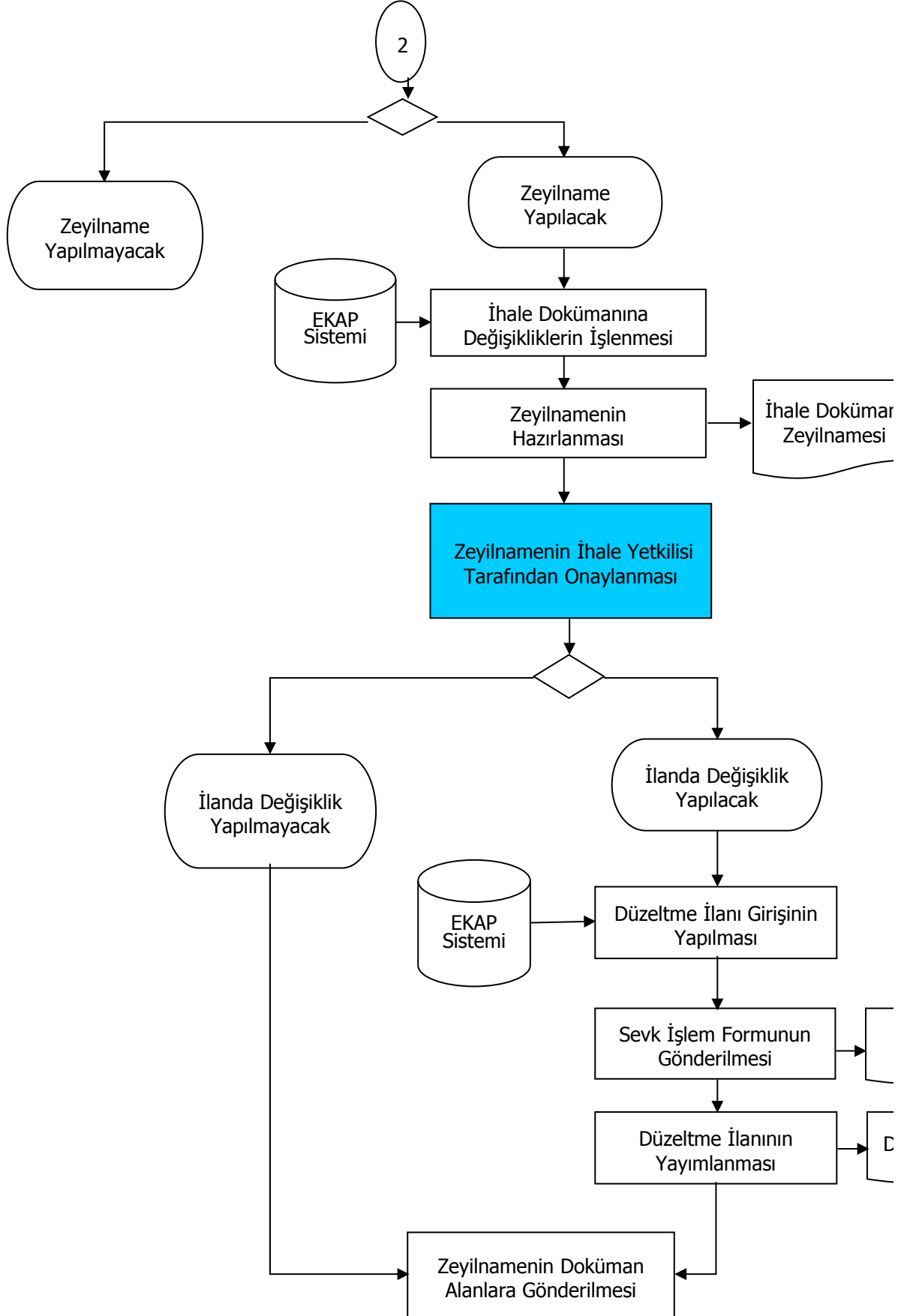

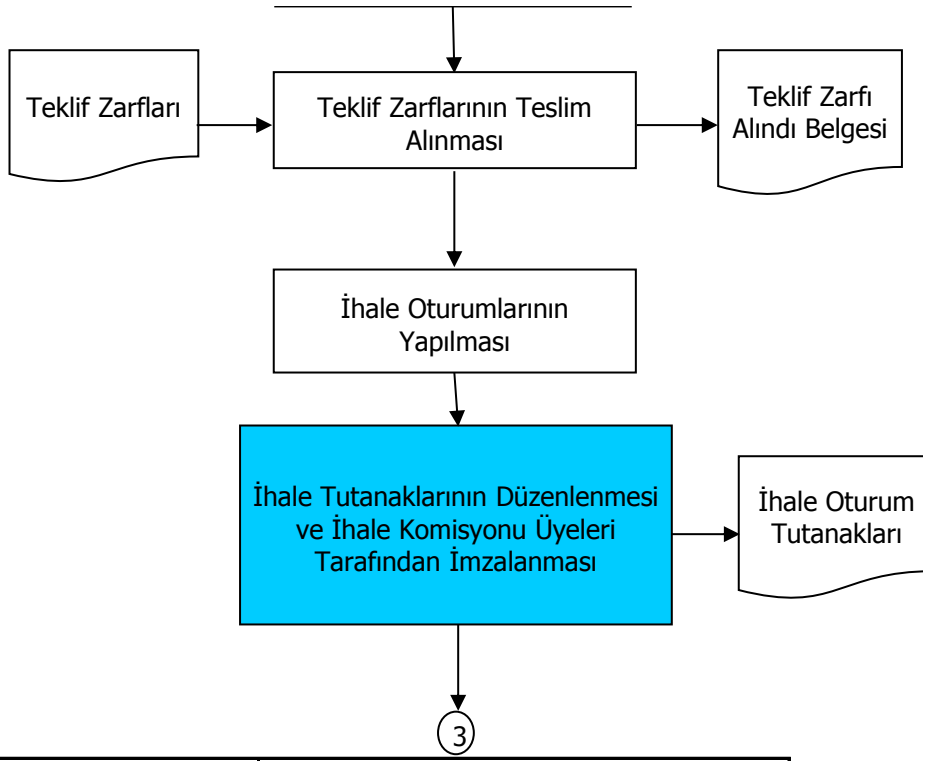

Hazırlayan:	Onaylayan:

ı Süreci

ni

Sevk İşlem
Formu

üzeltme İlanı

]

Açık İhale Usulüyle Mal ve Hizmet

3

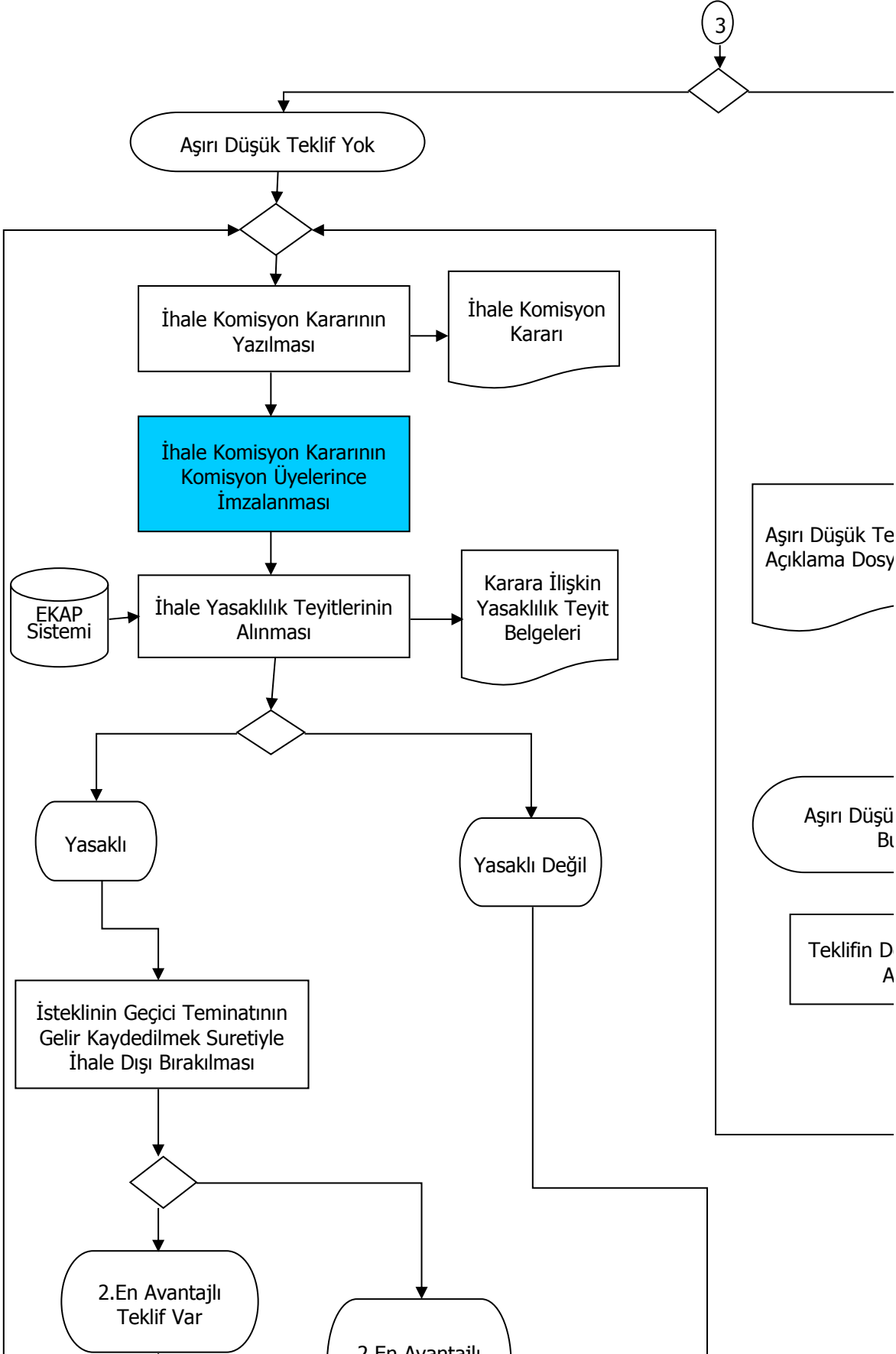

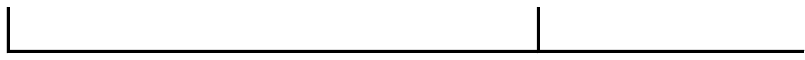

Alım İşlem Süreci

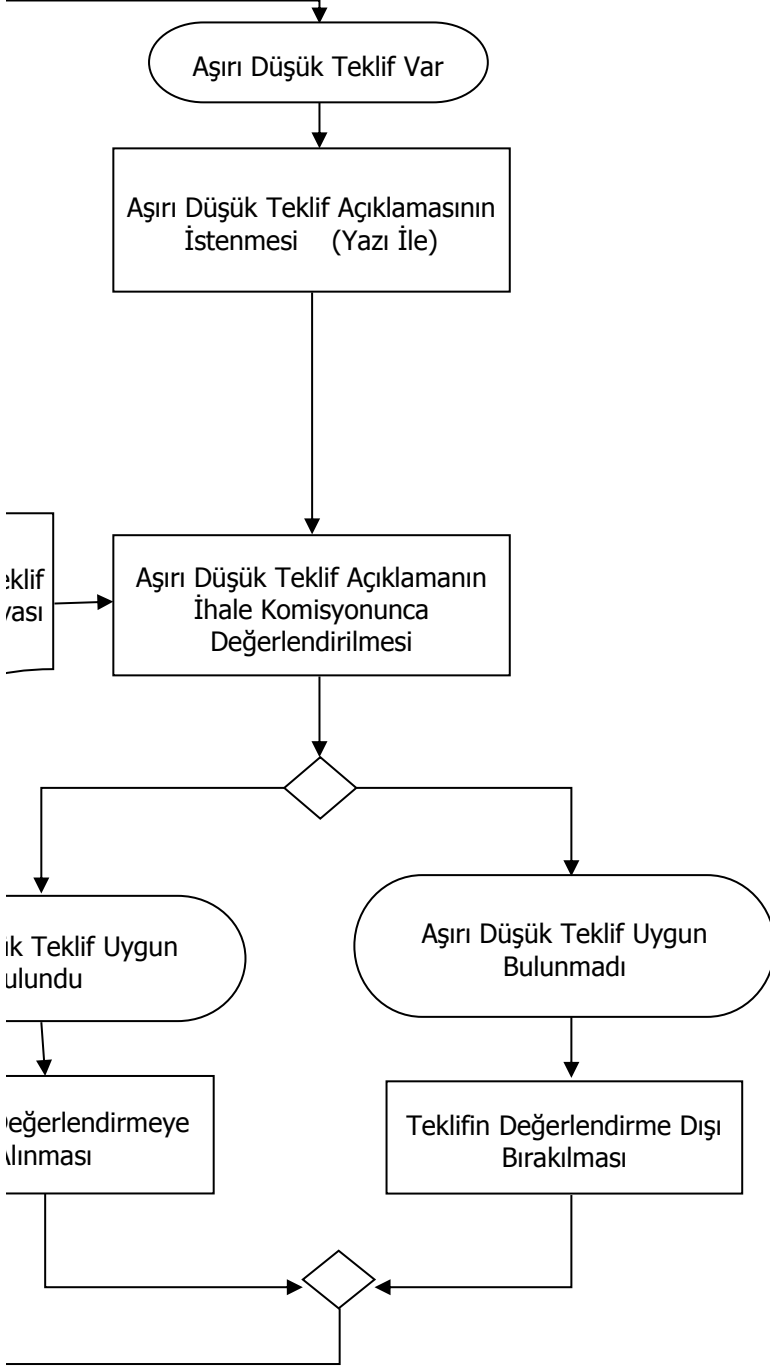

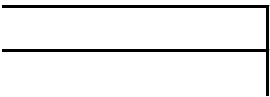
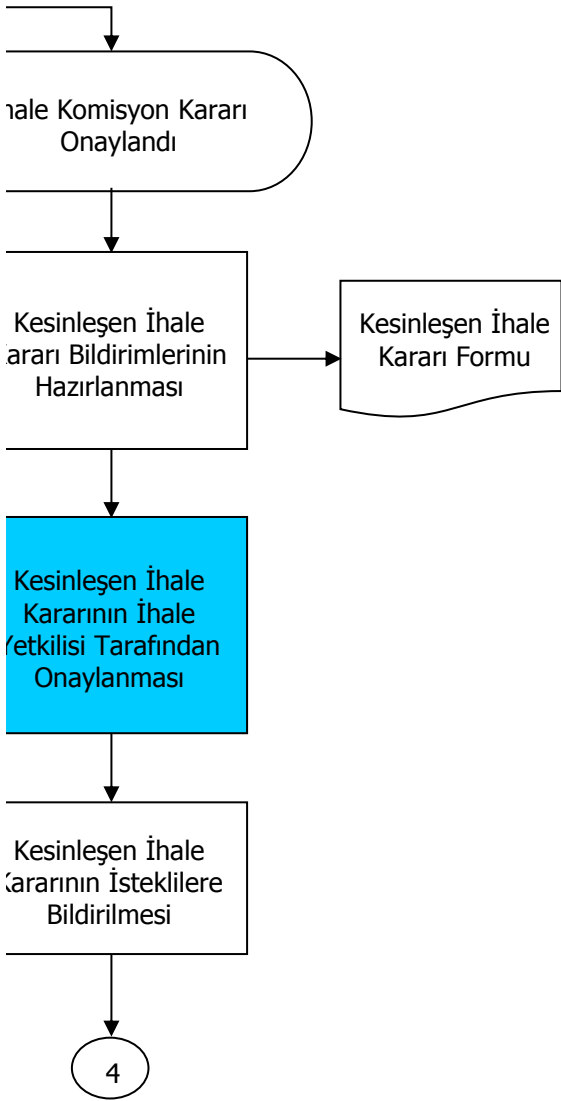



Açık İhale Usulüyle Mal ve Hizmet Alım İşlem

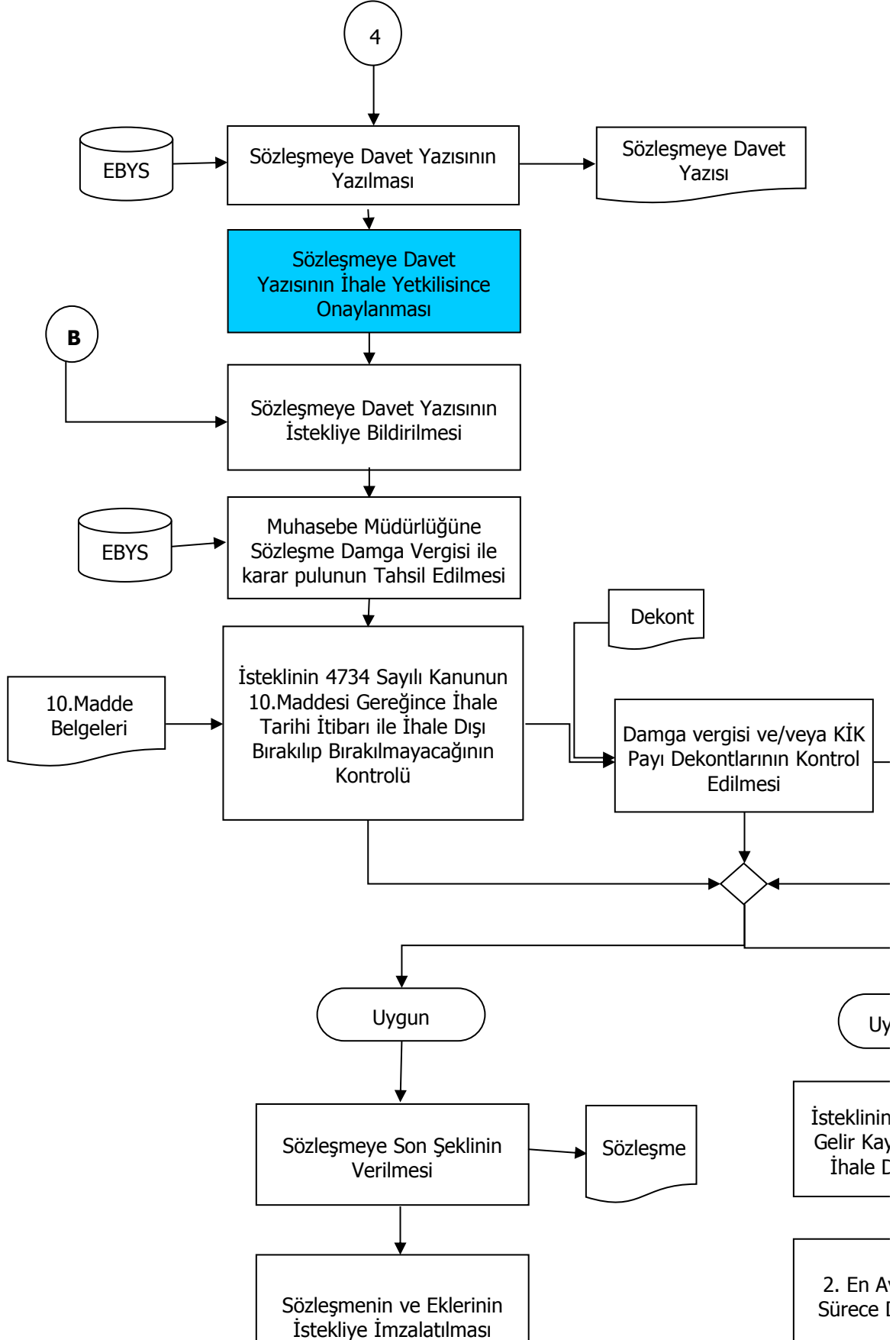

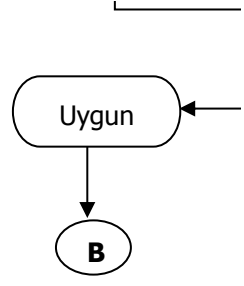
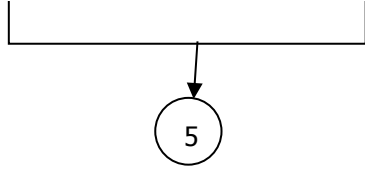

Hazırlayan:	Onaylayan:

ı Süreci

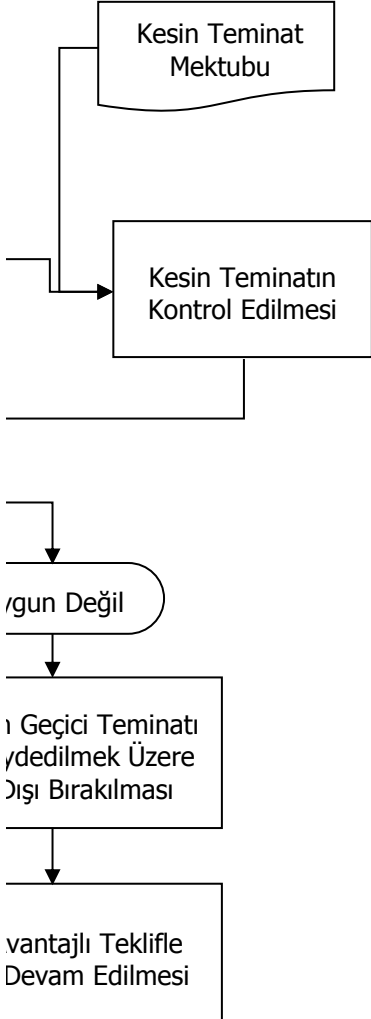

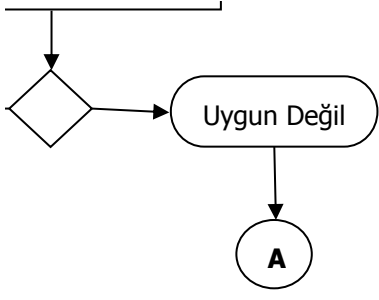

Açık İhale Usulüyle Mal ve Hizmet Alım İşlem Sü

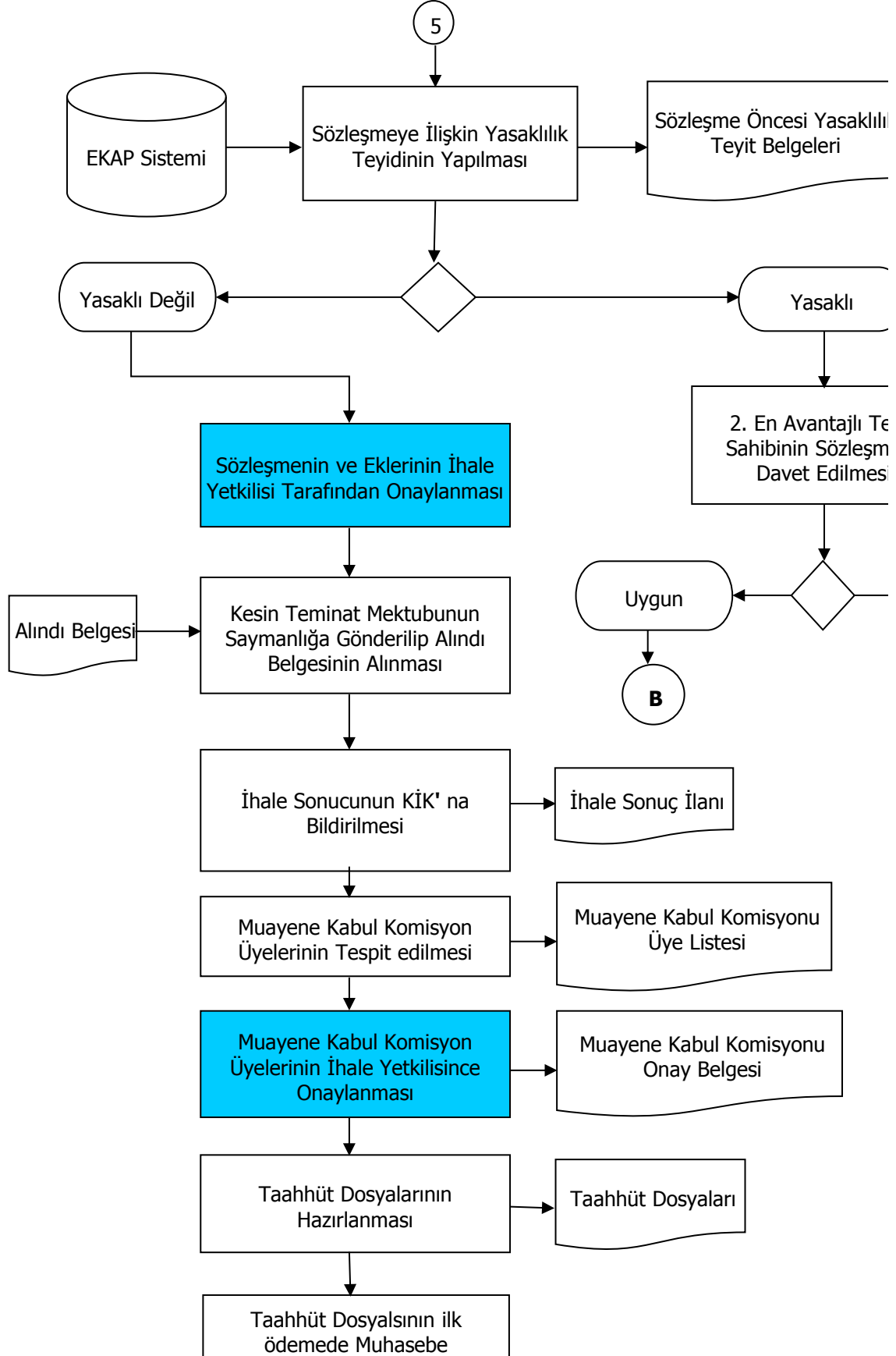

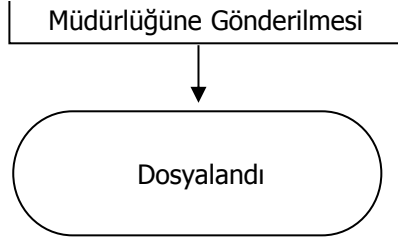

Hazırlayan:	Onaylayan:
	Personel Müdür V.

ireci

k

)

eklif
eye
i

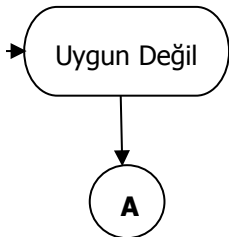



BURDUR Defterdarlığı Personel Müdürlüğü
Satınalma Servisi İşlemleri
Avans ve Kredi İşlemleri

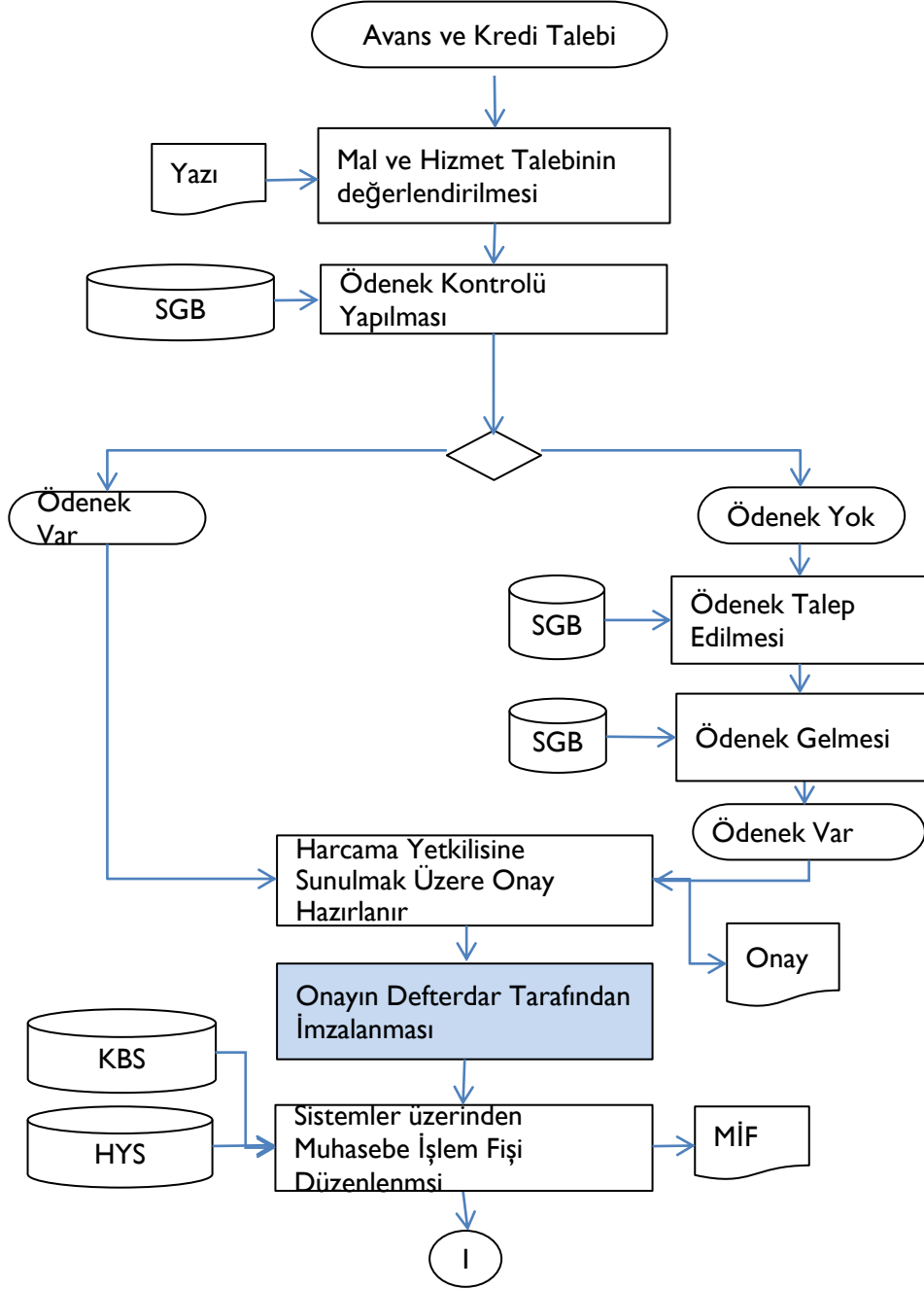

Hazırlayan:	Onaylayan:



BURDUR Defterdarlığı Personel Müdürlüğü
Satınalma Servisi İşlemleri

Avans ve Kredi İşlemleri

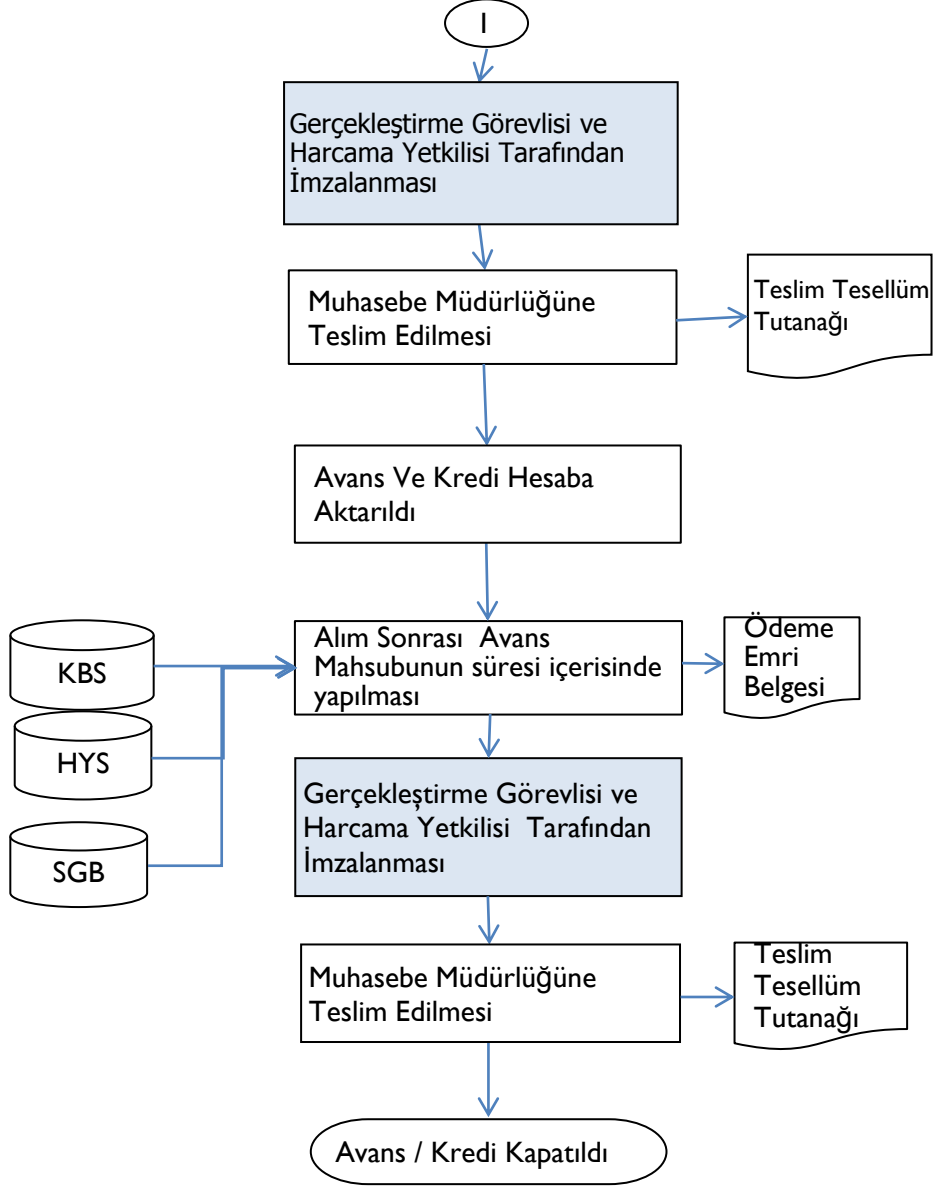

Hazırlayan:	Onaylayan:

BURDUR Defterdarlığı Personel Müdürlüğü

Bimer Kanalıyla Gelen Başvulara İlişkin İşlem Süreci

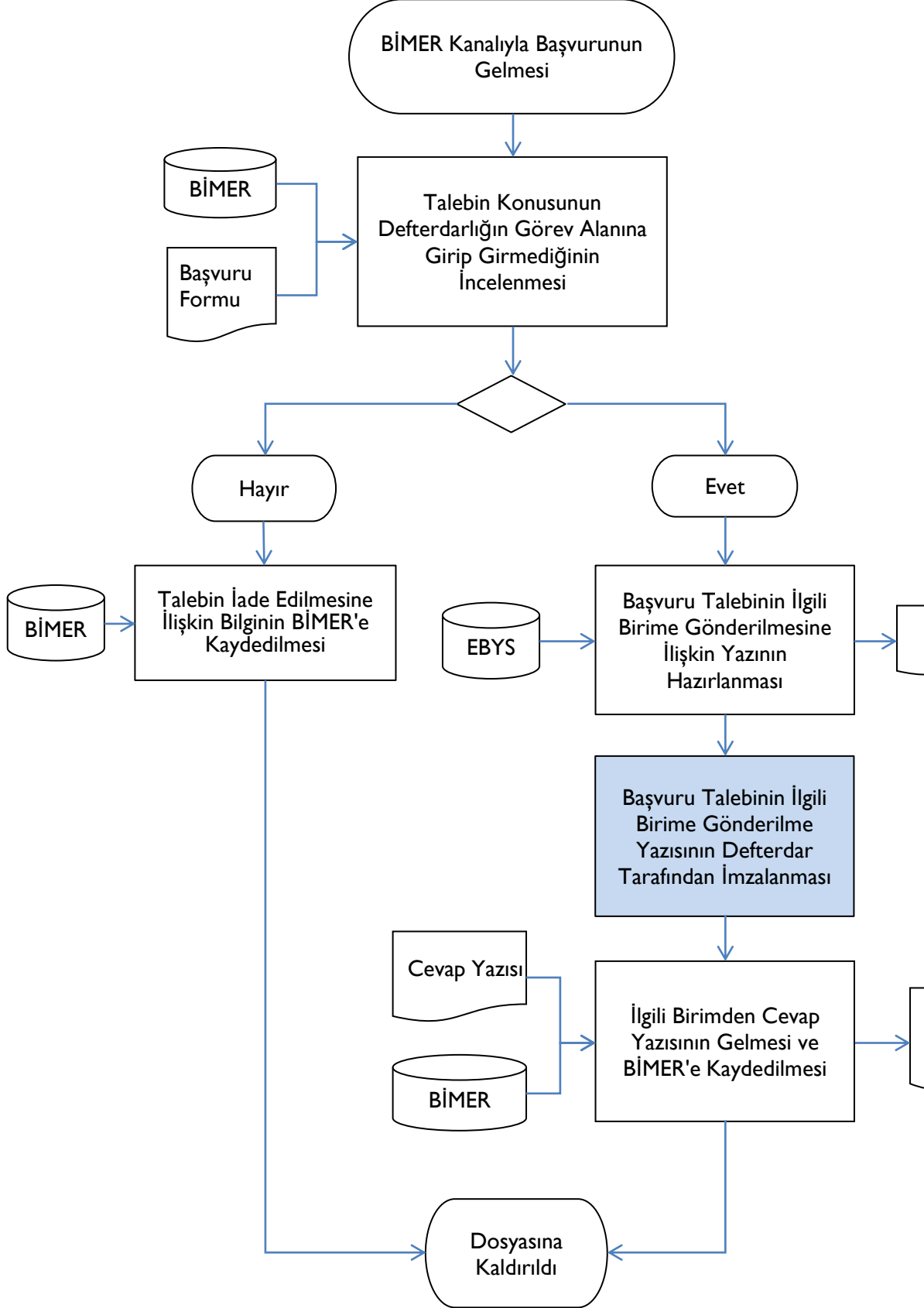

Hazırlayan:	Onaylayan:

Yazı

Form

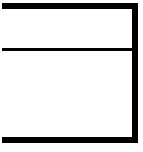



BURDUR Defterdarlığı Personel Müdürlüğü
Satınalma Servisi İşlemleri

Doğrudan Temin İşlem Süreci

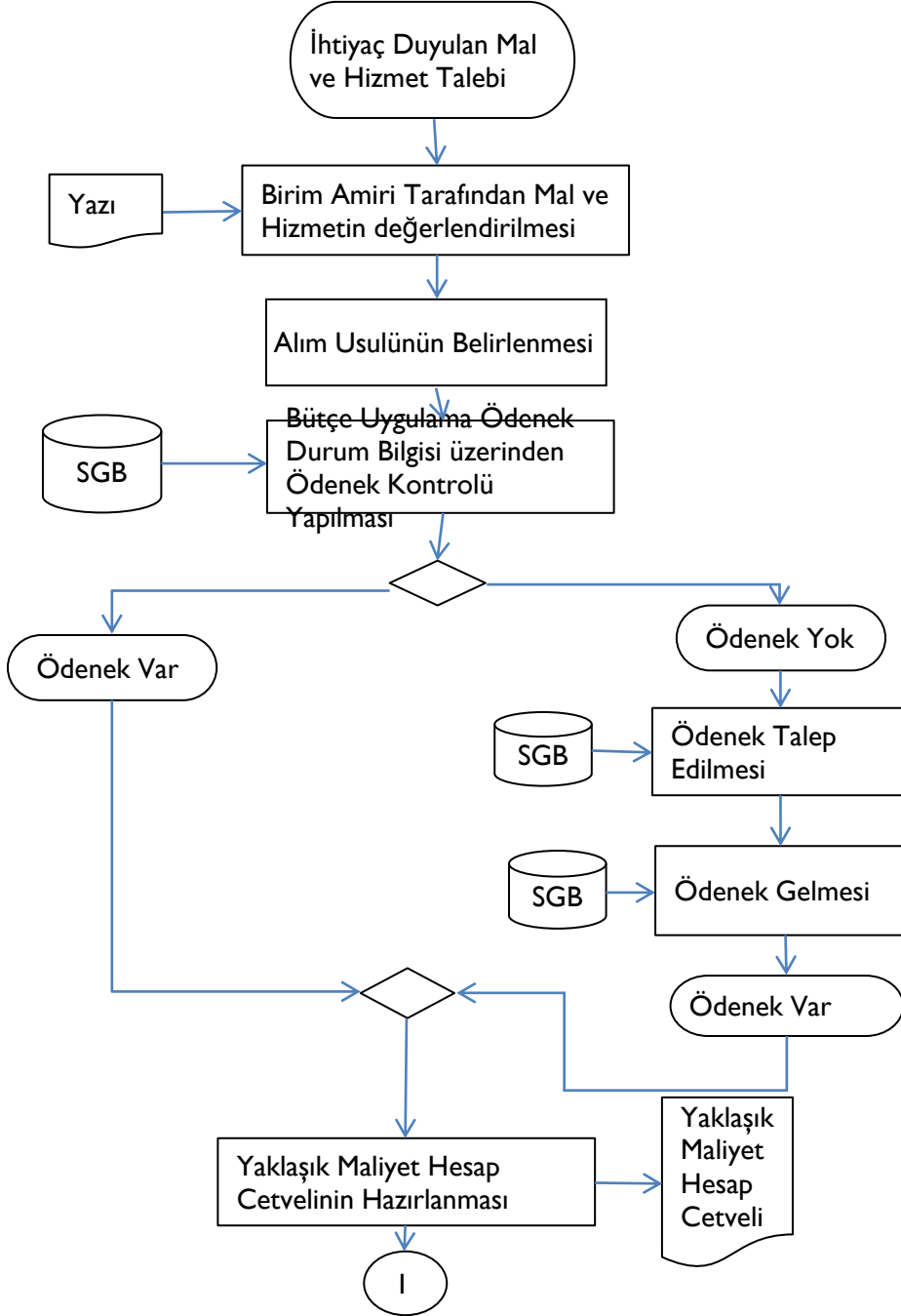

Hazırlayan:	Onaylayan:



BURDUR Defterdarlığı Personel Müdürlüğü
Satınalma Servisi İşlemleri

Doğrudan Temin İşlem Süreci

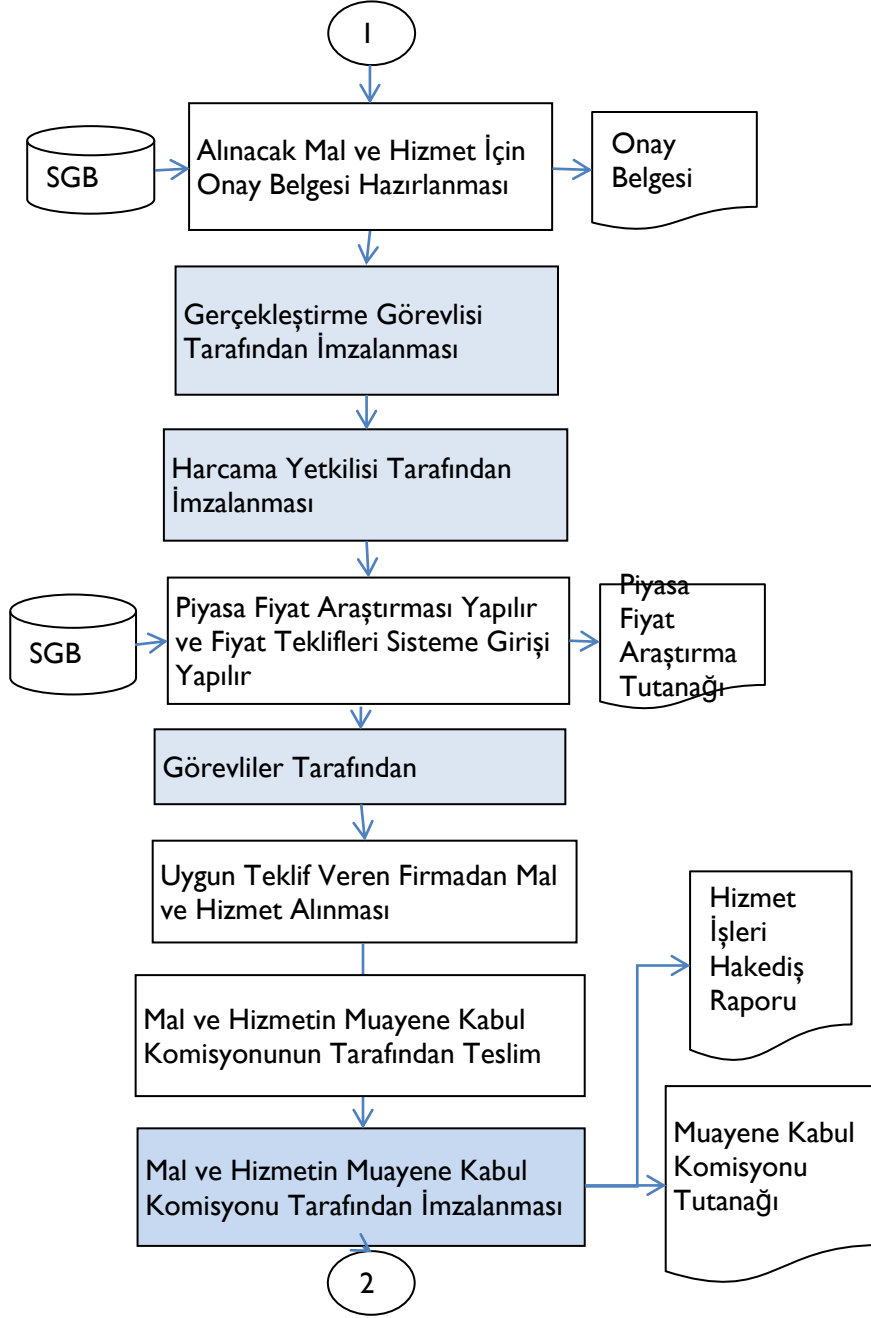

Hazırlayan:	Onaylayan:

Doğrudan Temin İşlem Süreci

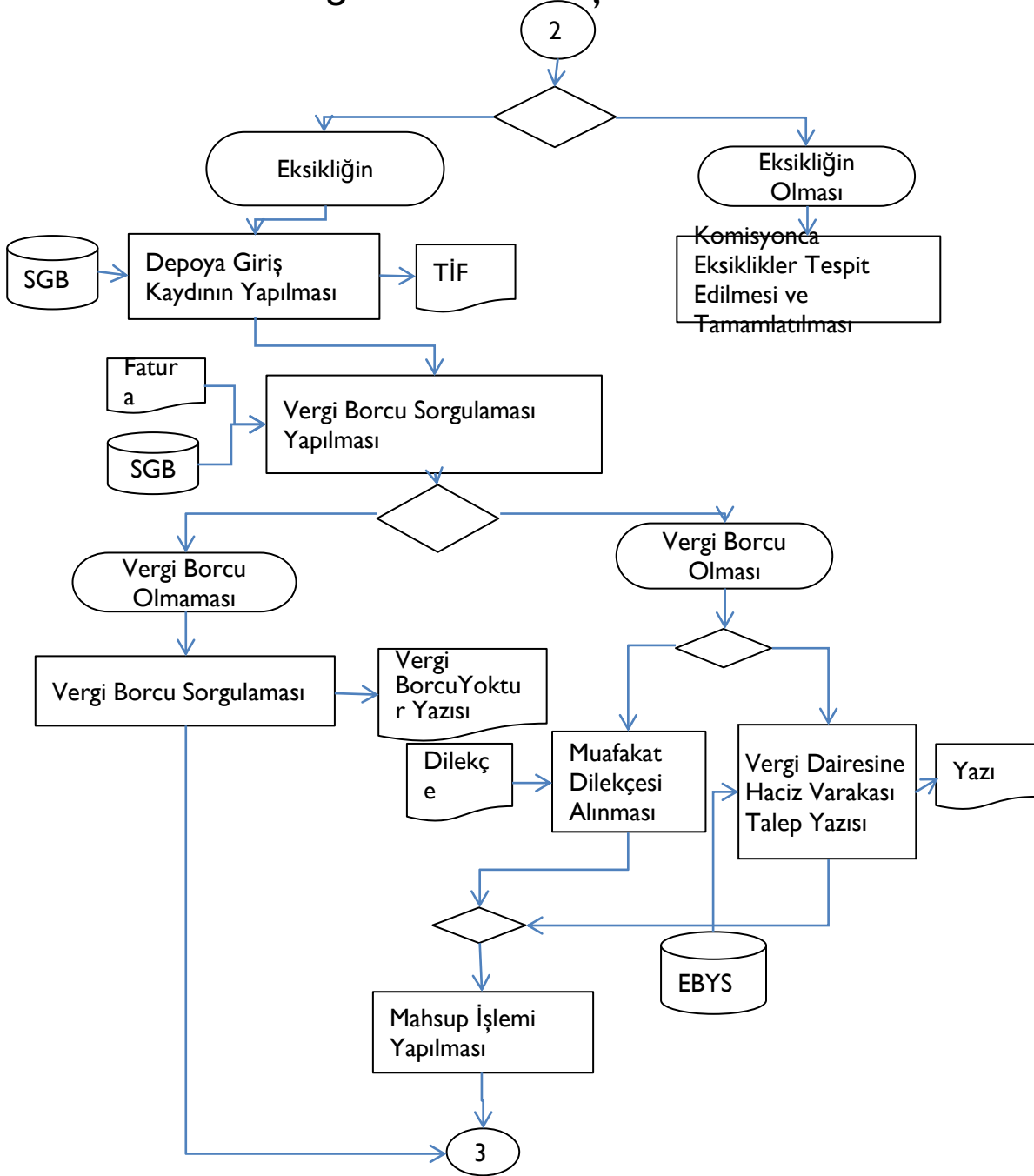

Hazırlayan:

Onaylayan:

--	--

BURDUR Defterdarlığı Personel Müdürlüğü
Satınalma Servisi İşlemleri
Doğrudan Temin İşlem Süreci

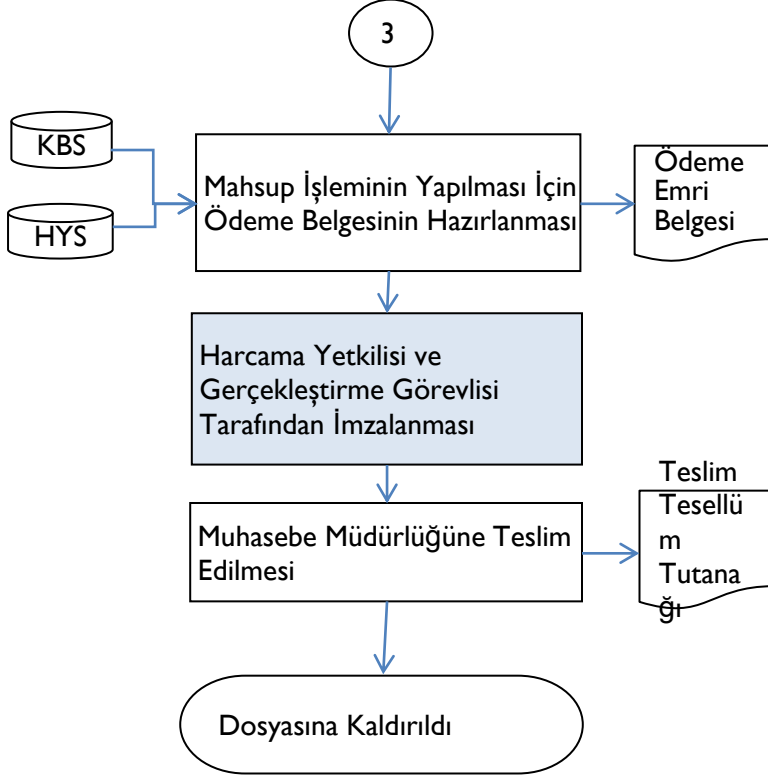

Hazırlayan:	Onaylayan:



BURDUR Defterdarlığı Personel Müdürlüğü

Defterdarlık Makamı Ve Müdürlüğe Ait Telefon, Elektrik

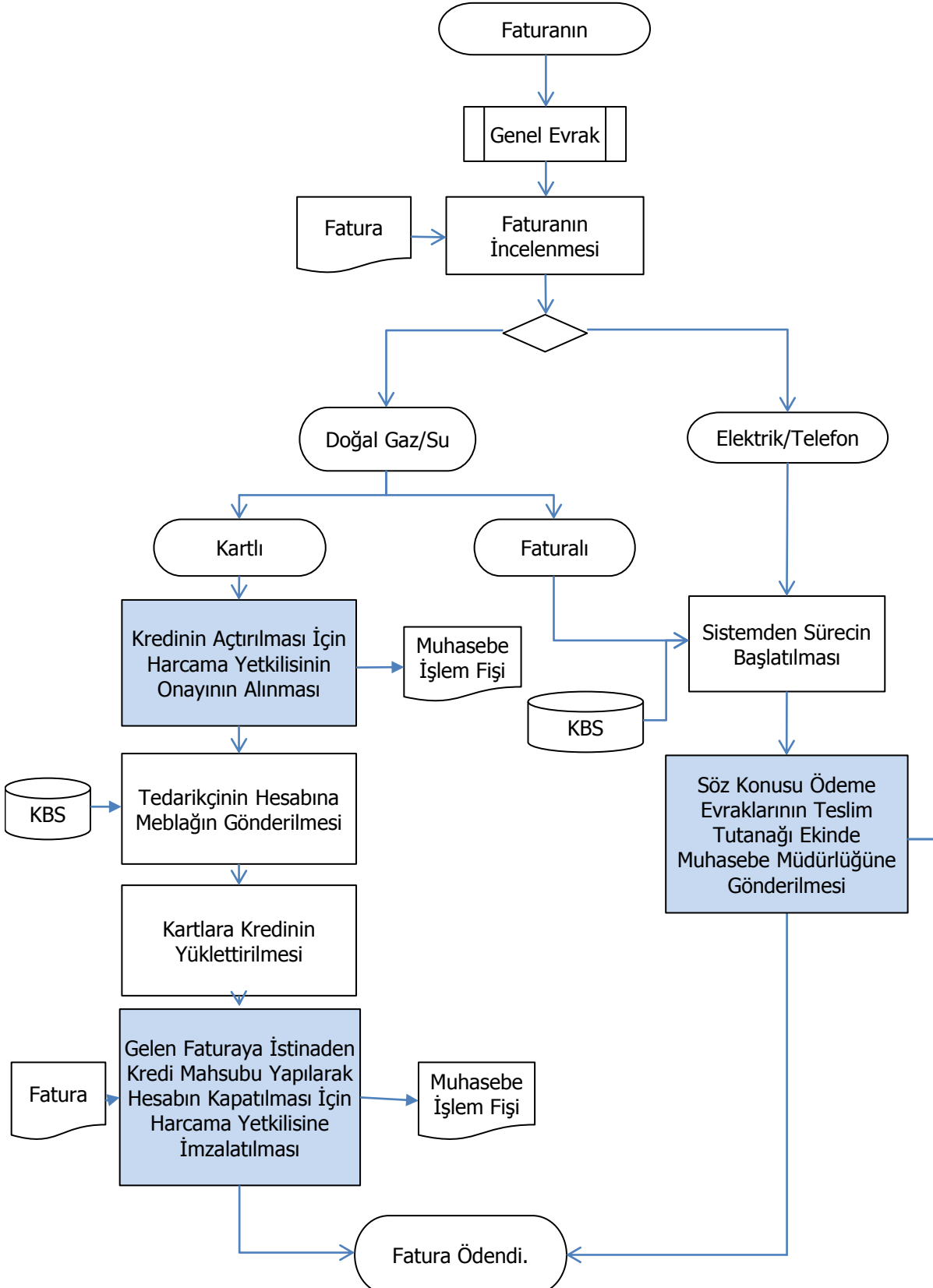



Hazırlayan:	Onaylayan:

Ödeme, Su, Isıtma İşlem

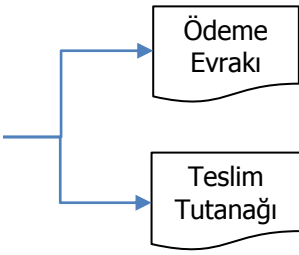

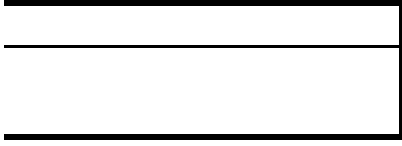

BURDUR Defterdarlığı Personel Müdürlüğü Giyecek Yardımları İşlem Sü

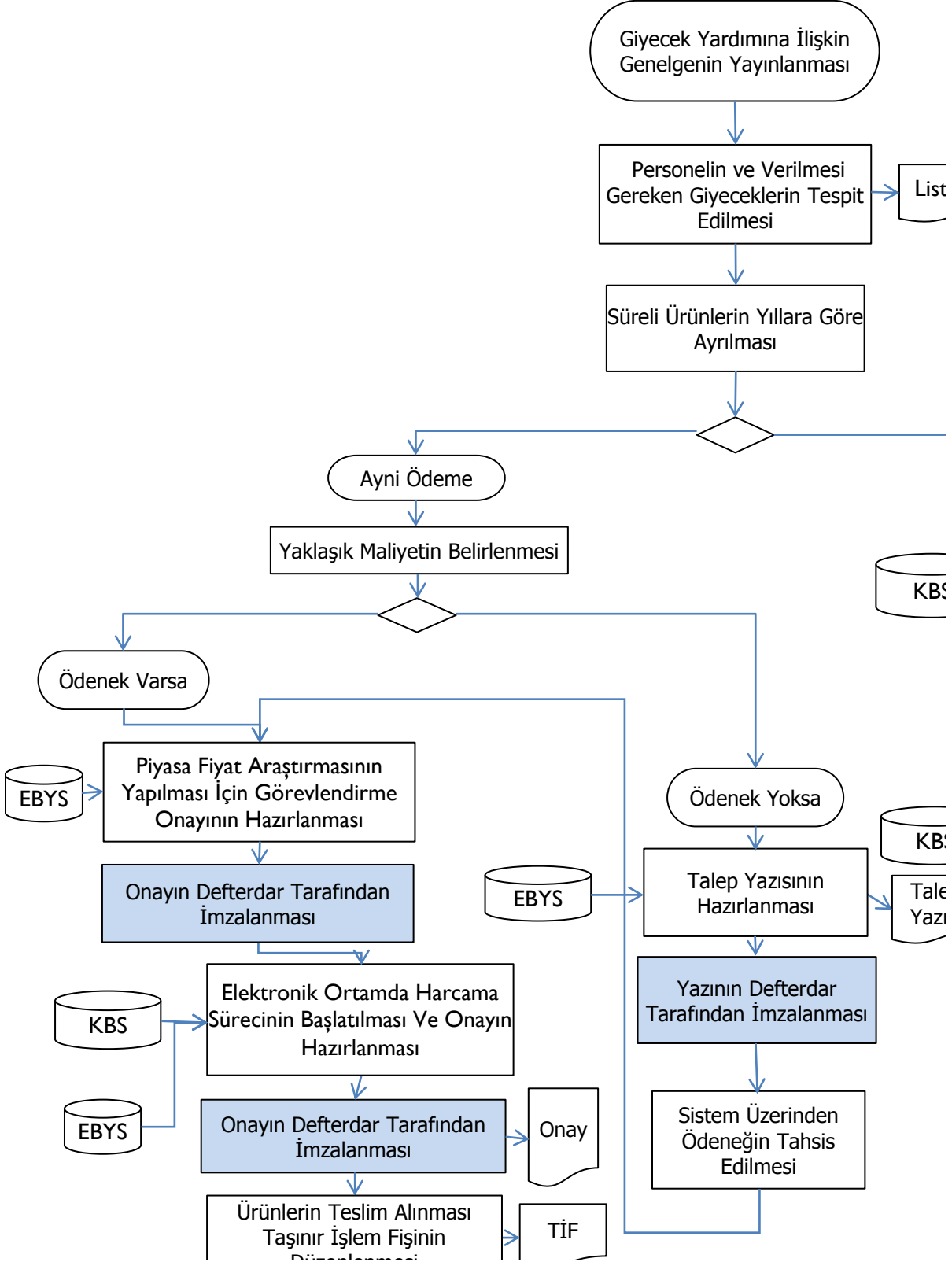

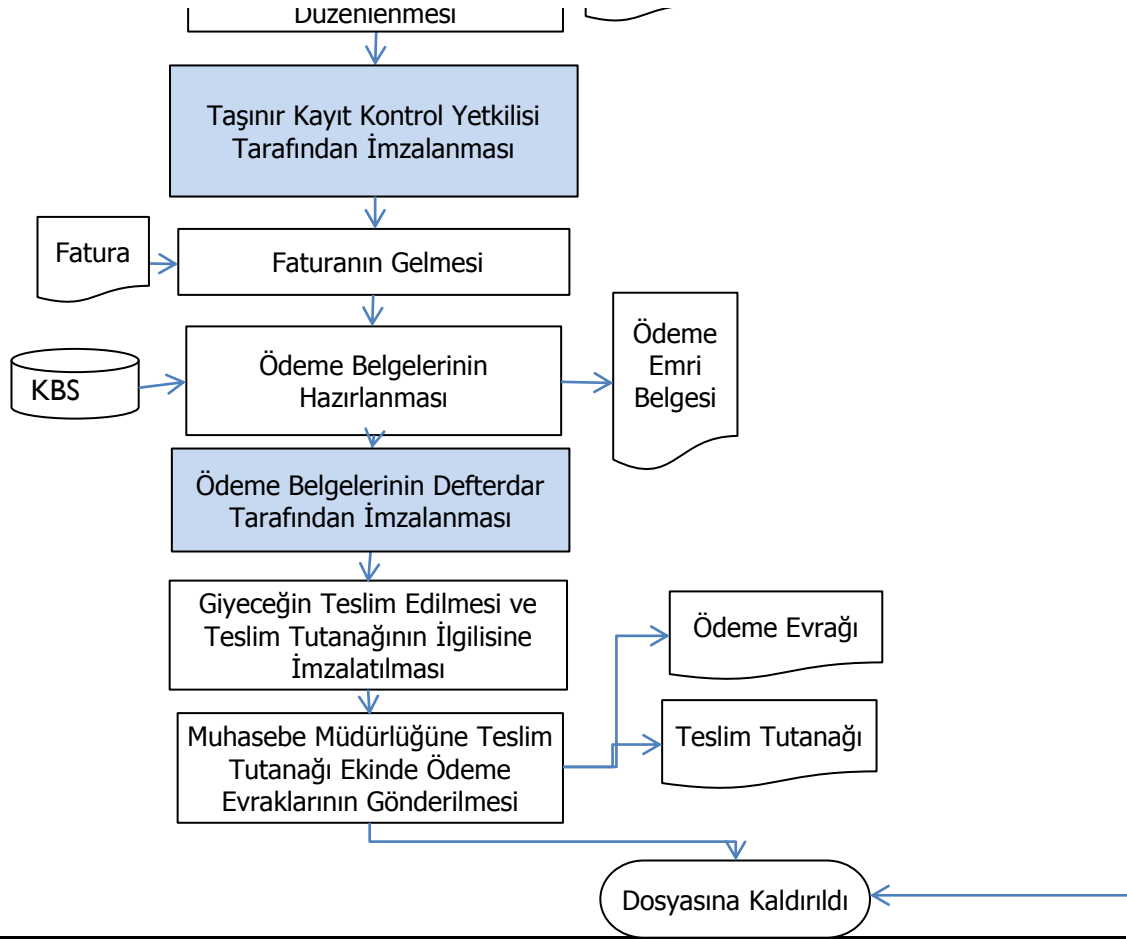

Hazırlayan:	Onaylayan:

reci

te

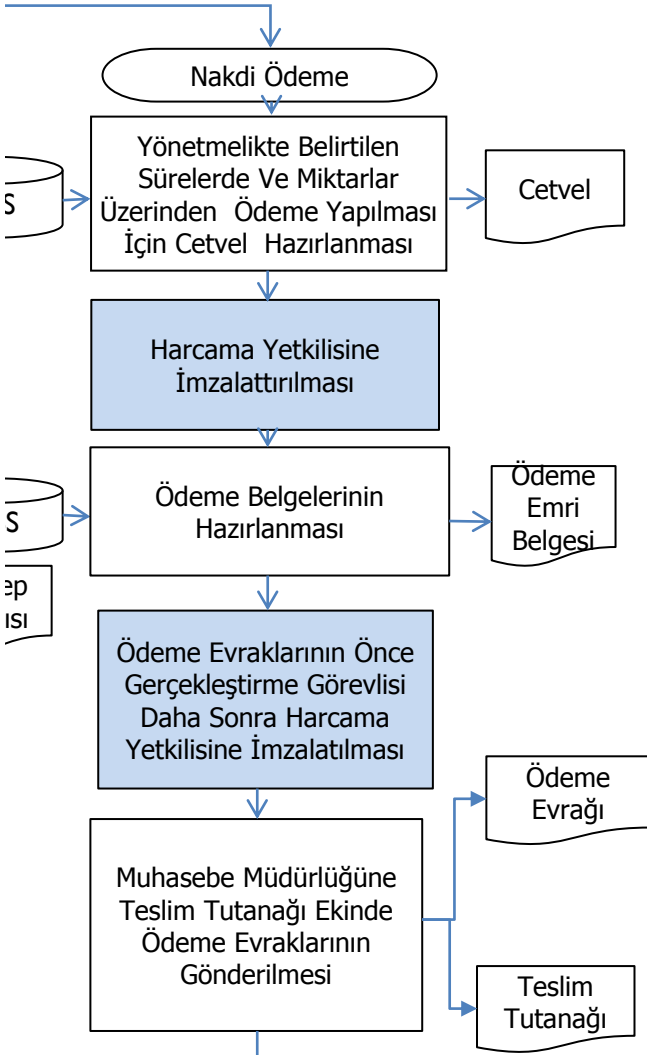

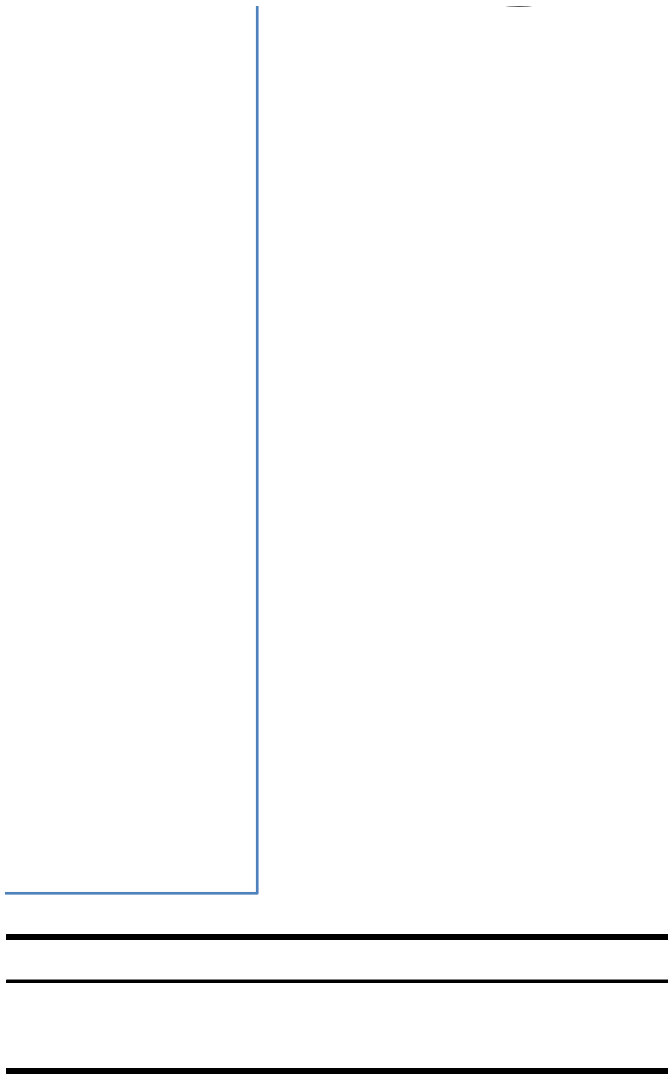

Hazırlayan:

Onaylayan:

--

--

siz

sisnın



Ödenek
Talep
Yazısı

rafından

ğın Tahsis

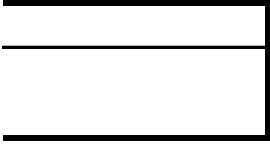



Hurdaya Ayrılan Taşınırın İmha Süreci

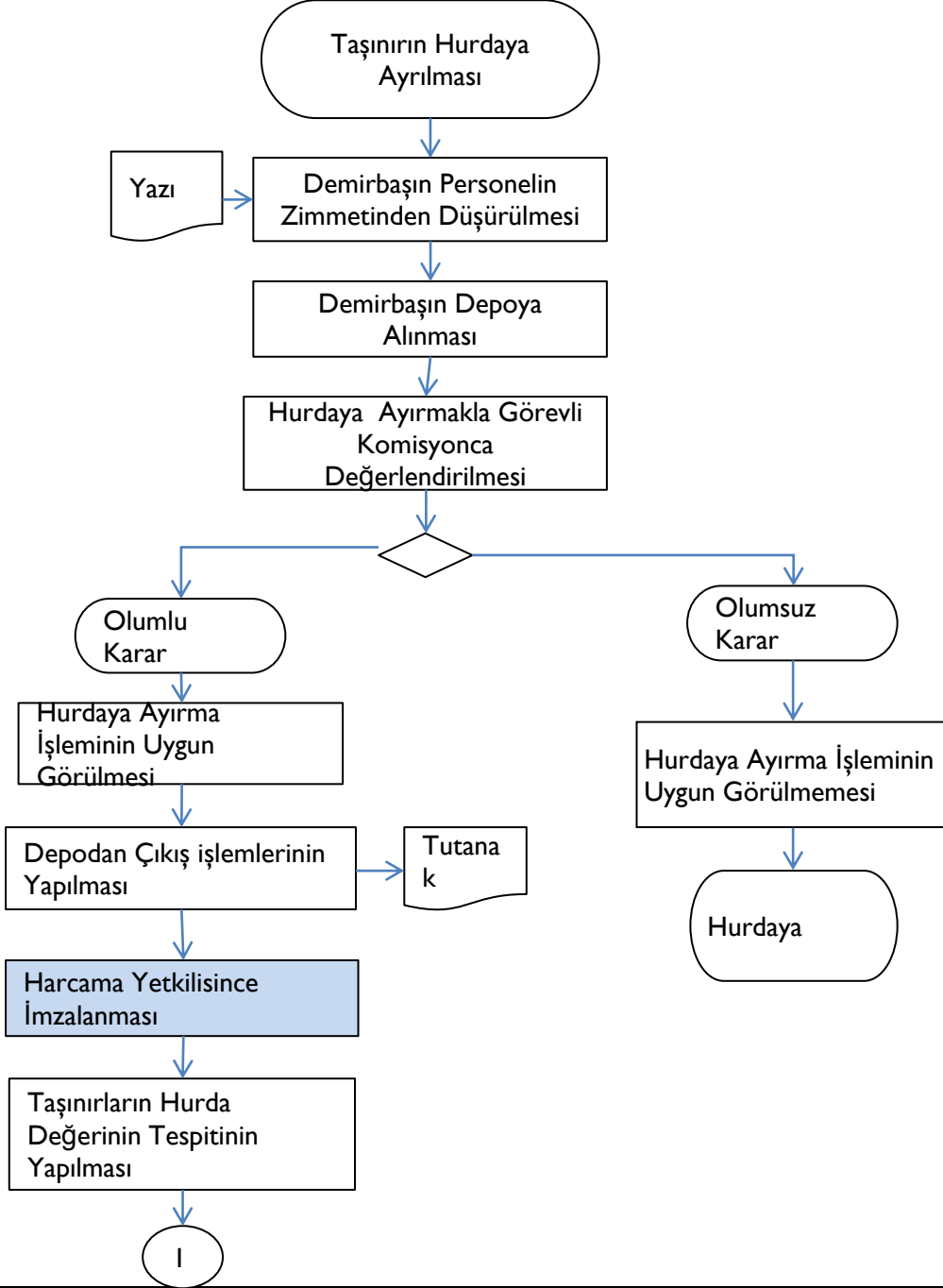

Hazırlayan:	Onaylayan:



Hurdaya Ayrılan Taşınırların İmha Süreci

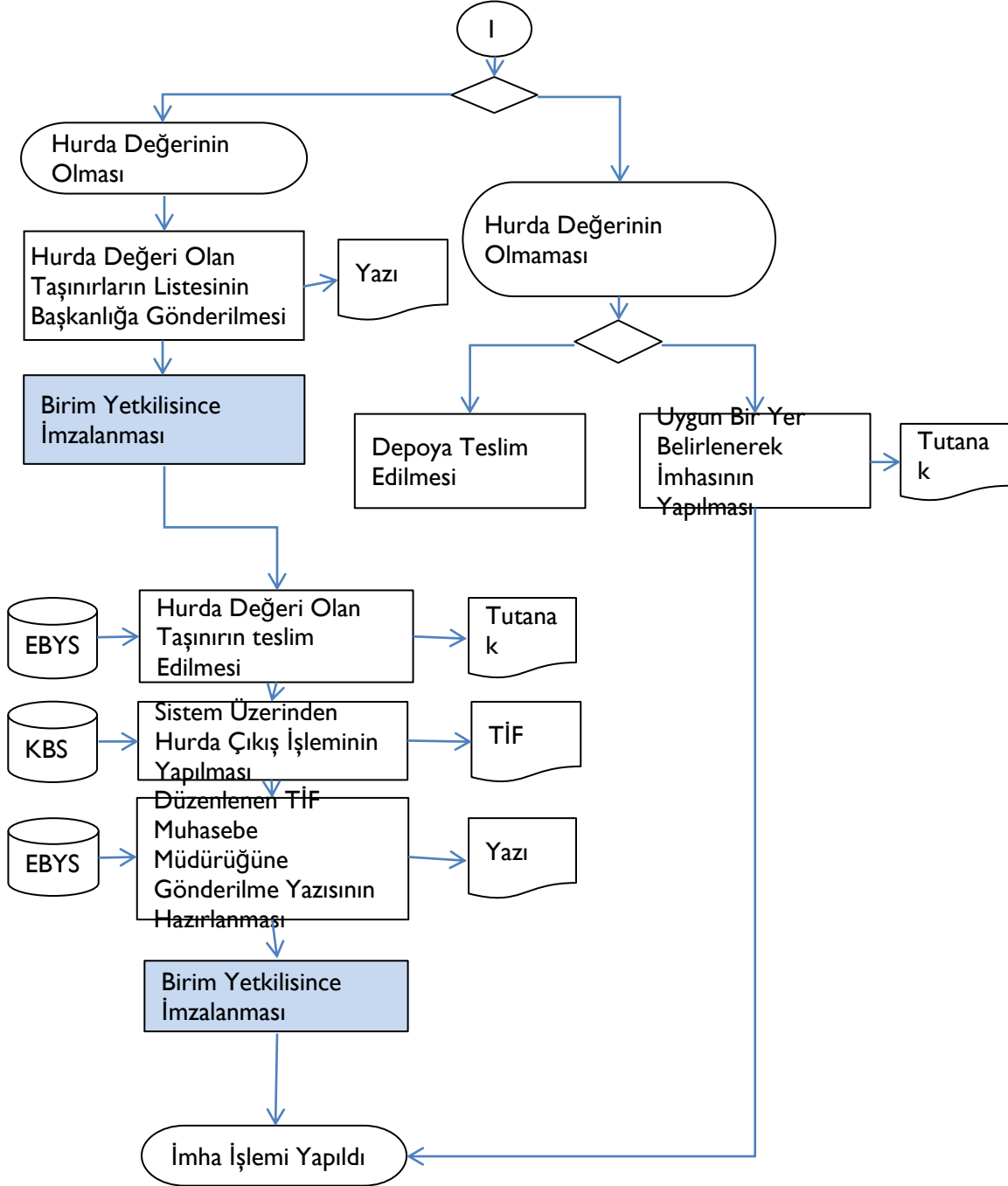

Hazırlayan:	Onaylayan:

BURDUR Defterdarlığı Personel Müdürlüğü
Personel ve Özlük Servisi İşlemleri
İŞÇİ MAAŞ İŞLEMLERİ SÜRECİ

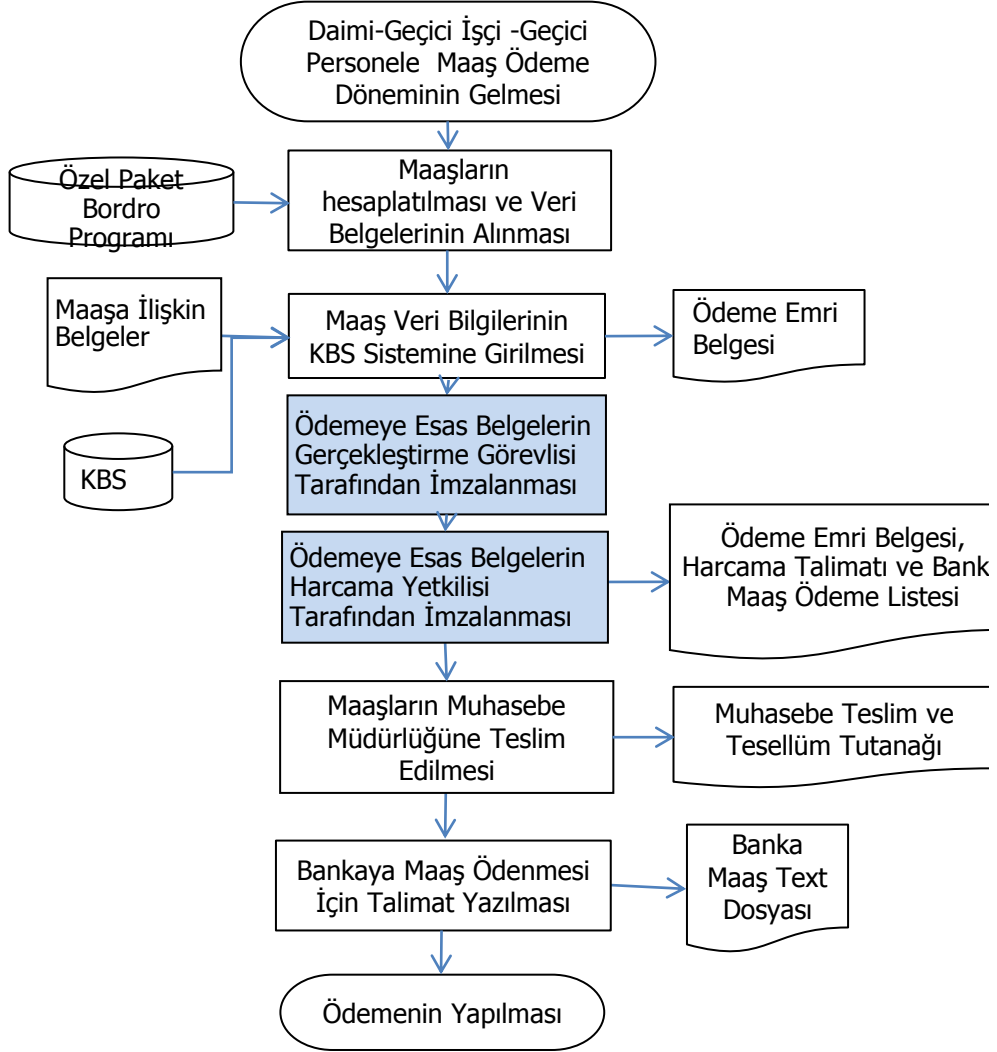

Hazırlayan	Onaylayan

a

]

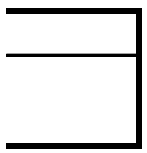



BURDUR Defterdarlığı Personel Müdürlüğü Keseneklerin SGK'ya Gönderilme İşlem Süreci

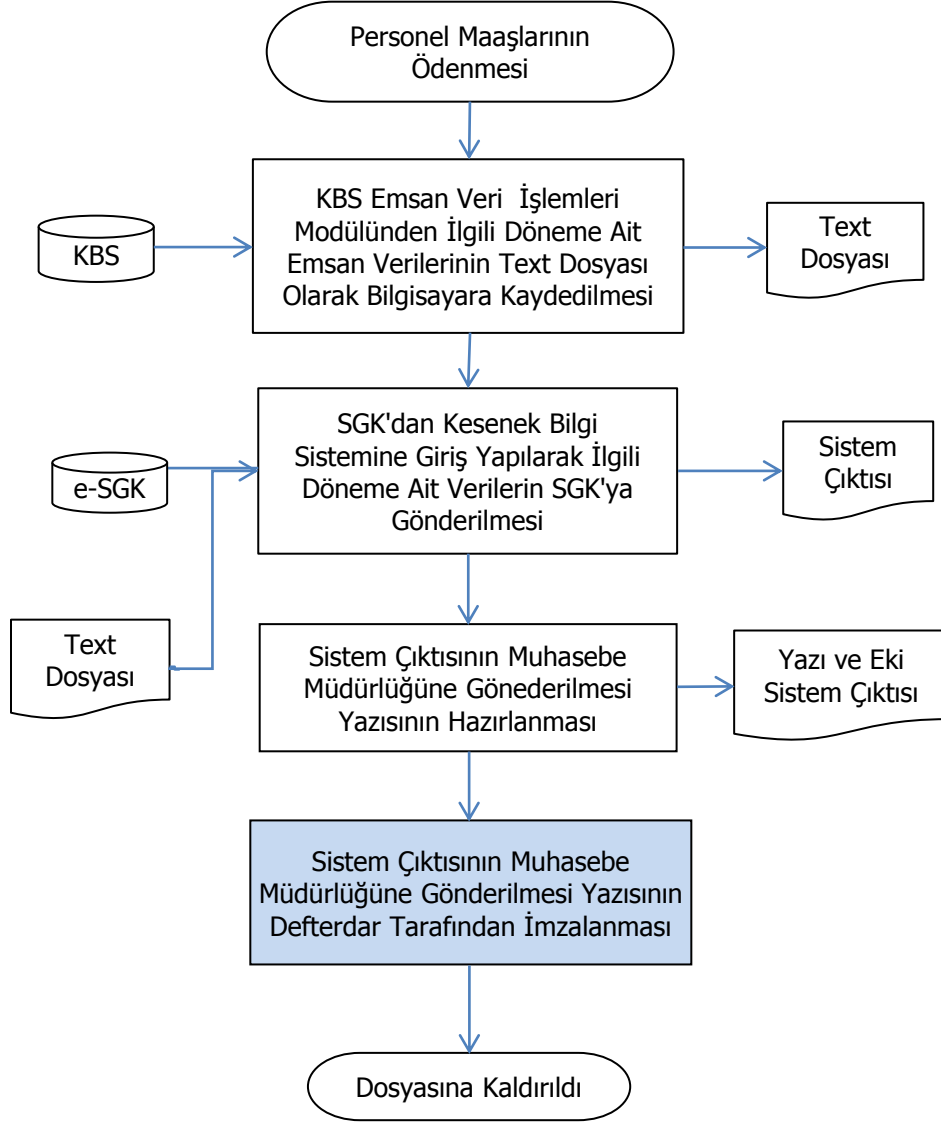

Hazırlayan:

Onaylayan:

--	--

Memur Aylık Ödemeleri İşlemleri Süreci

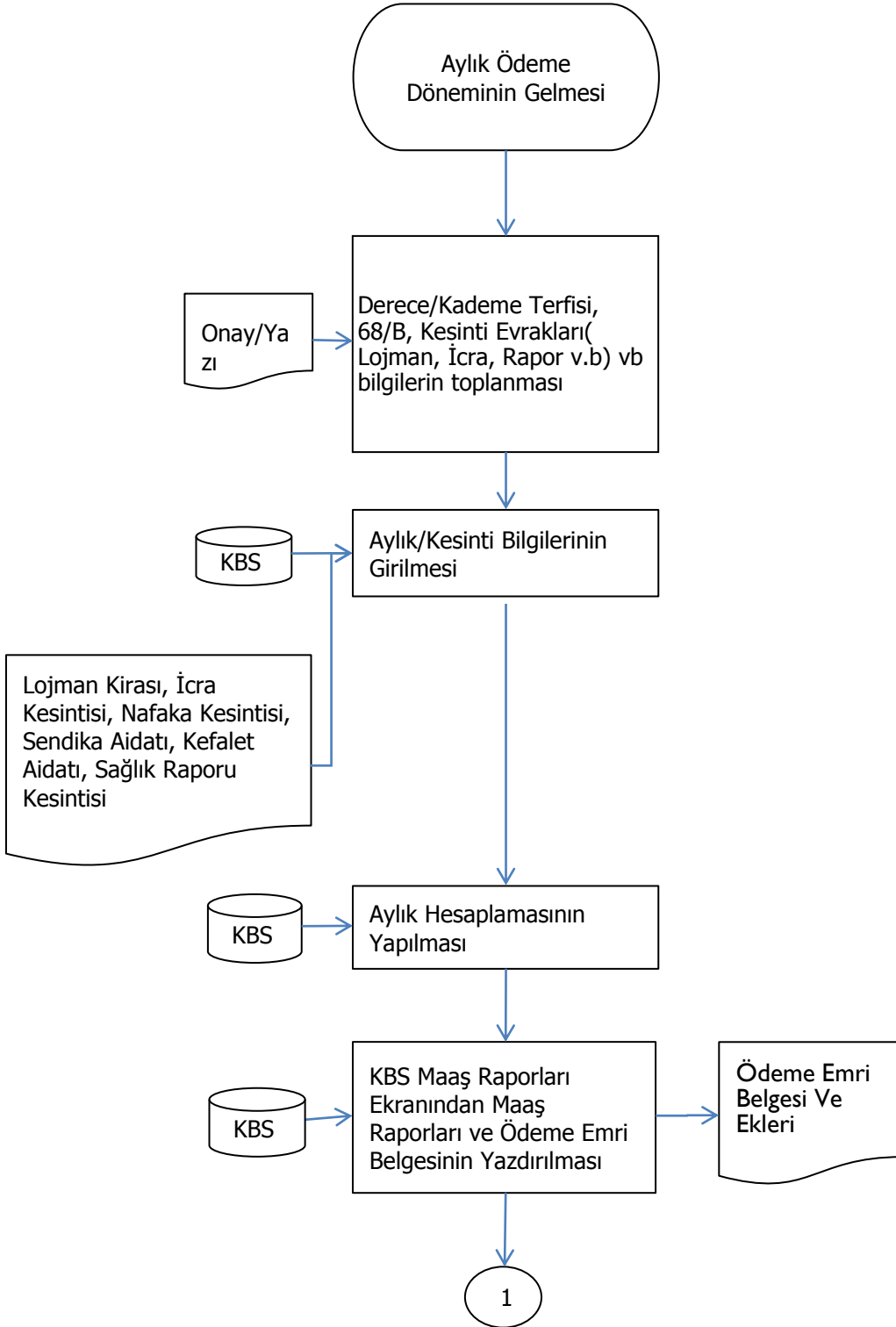



BURDUR Defterdarlığı Personel Müdürlüğü
Personel ve Özlük Servisi İşlemleri
Memur Maaş İşlemleri Süreci

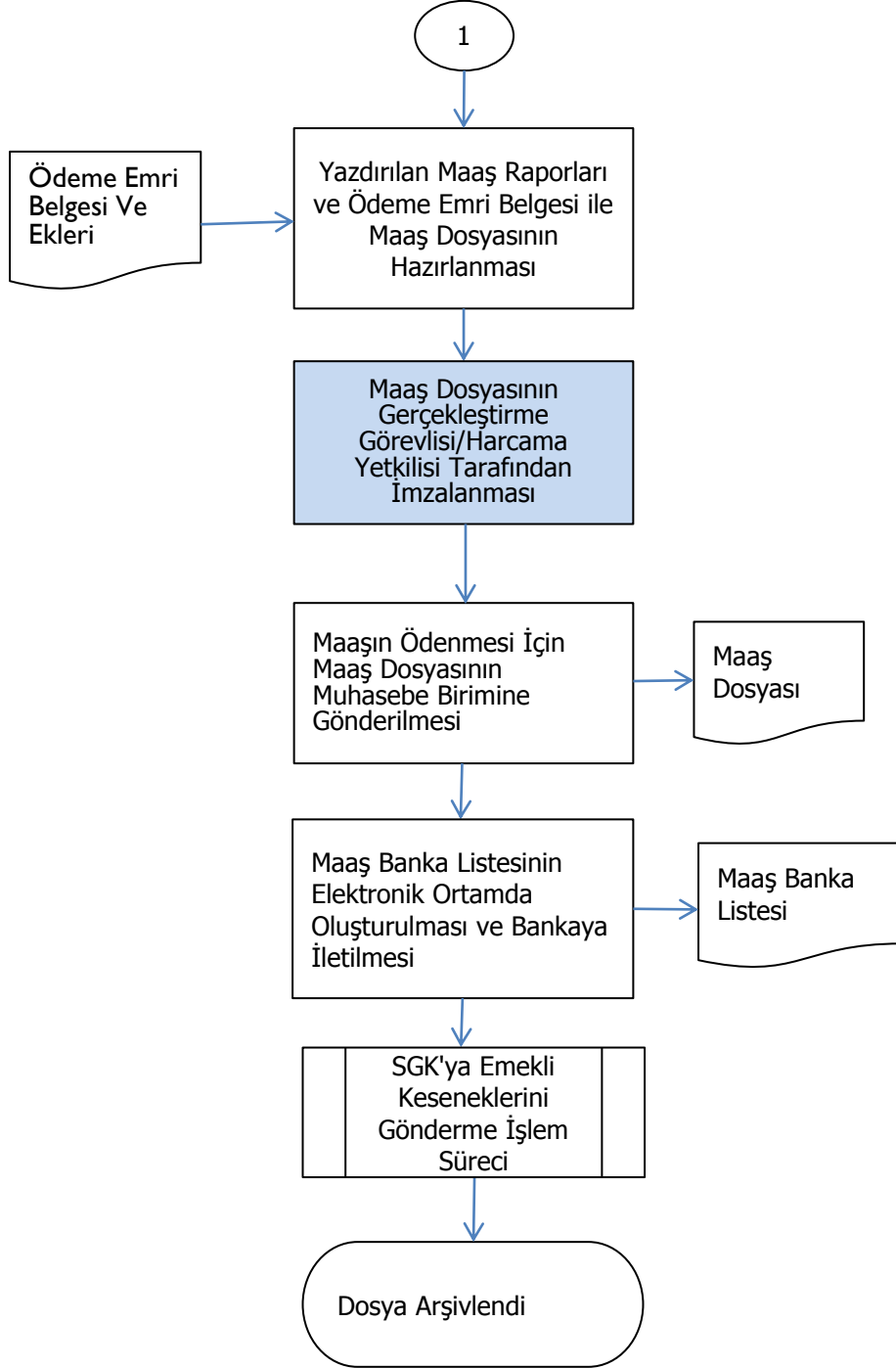

Hazırlayan:

Onaylayan:

--	--



BURDUR Defterdarlığı Personel Müdürlüğü Genel Kadro Değişikliği İşlem Süreci

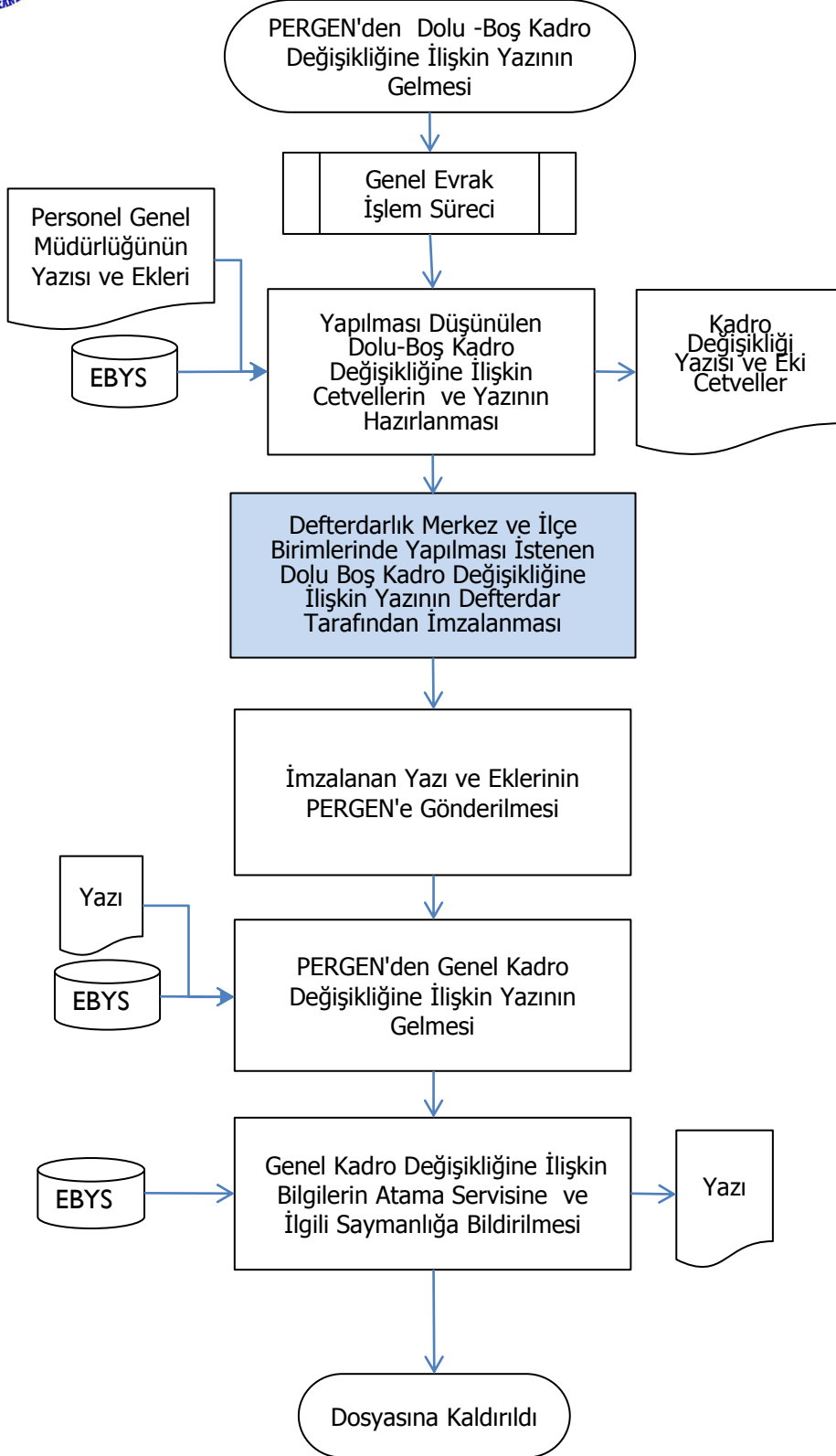

Hazırlayan:

Onaylayan:





BURDUR Defterdarlığı
Personel Müdürlüğü
İl İçi Kadro Tenkis-Tahsis İşlem Süreci

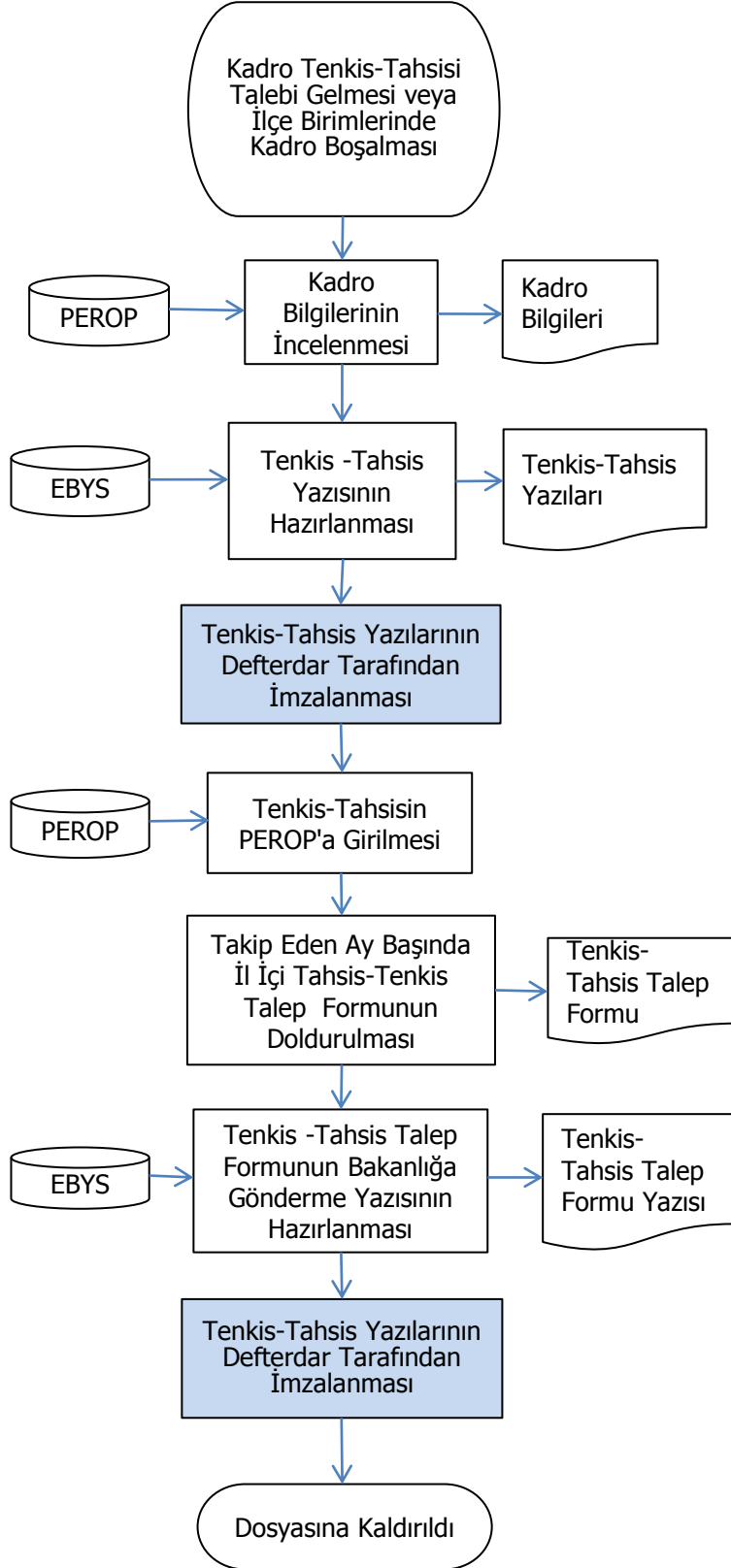

Hazırlayan:

Onaylayan:

--	--



BURDUR Defterdarlığı
Personel Müdürlüğü

Bakanlık Tarafından Tahsis/Tenkis Edilen Kadrolar İşlem Süreci

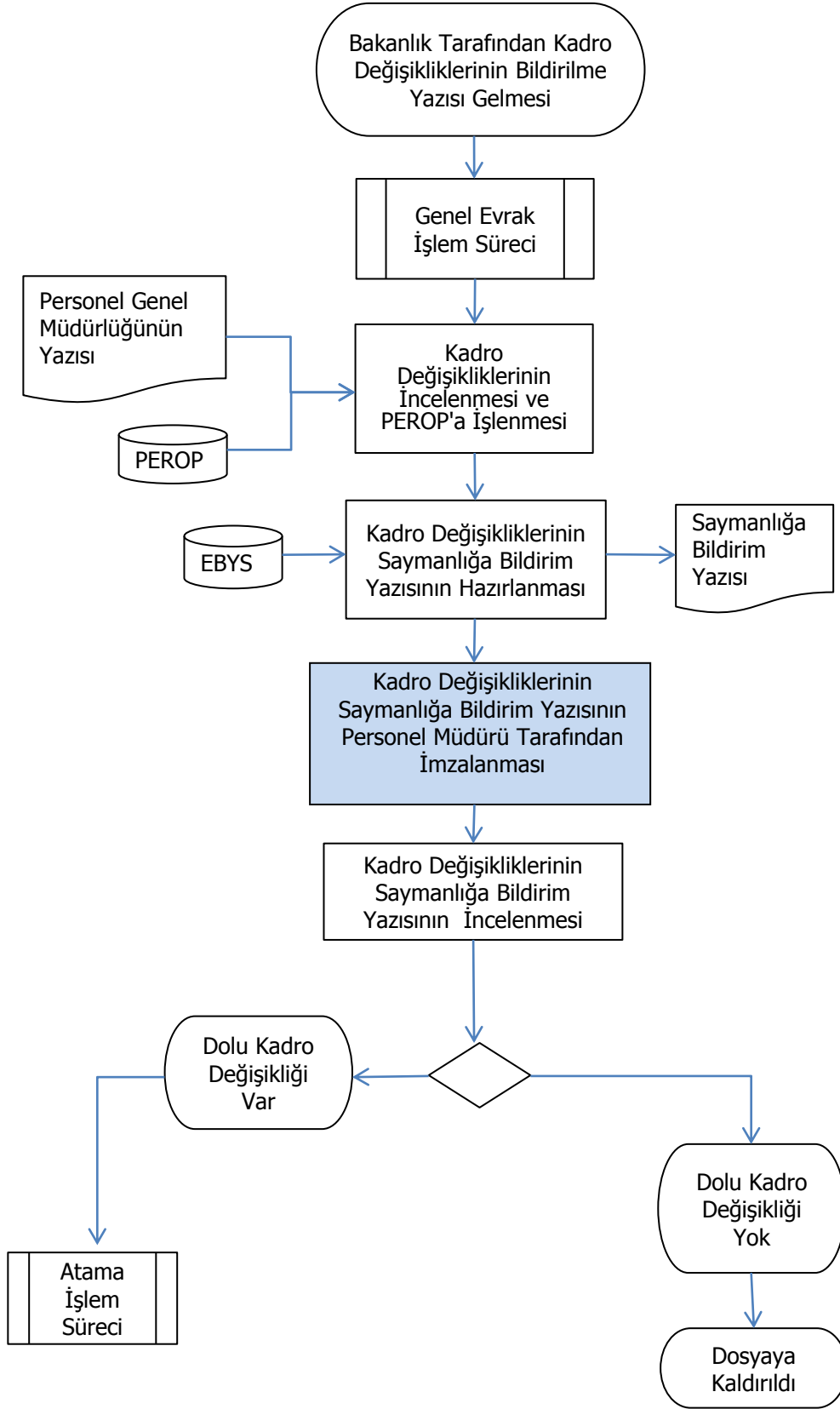

Hazırlayan:	Onaylayan:



BURDUR Defterdarlığı
Personel Müdürlüğü
Personel Hareketleri İstatistik Formları

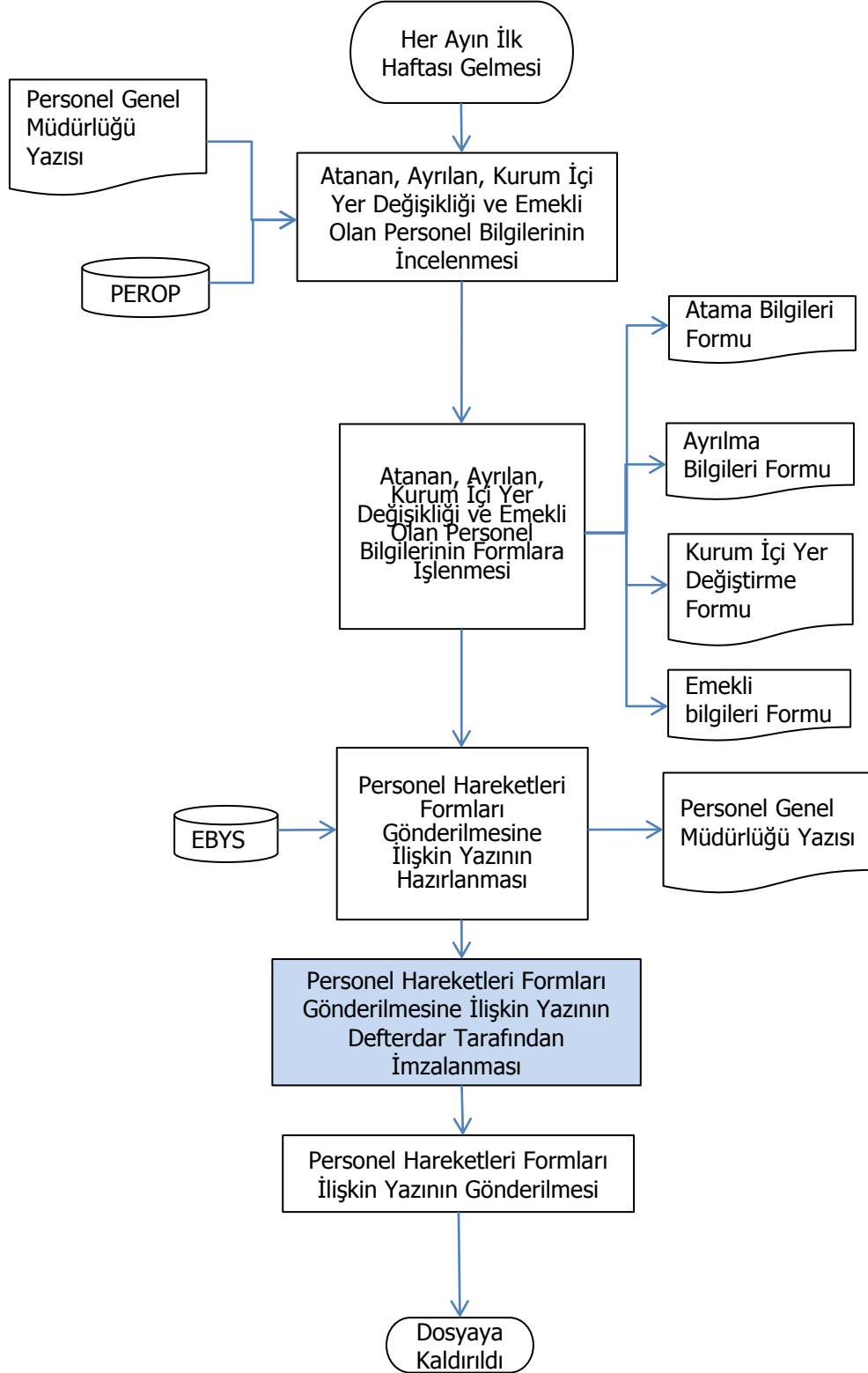

Hazırlayan:

Onaylayan:

--	--



BURDUR Defterdarlığı Personel Müdürlüğü

Personel Bilgi Formu/Engelli Personeli Bilgilerinin Hazırlanması İşlem

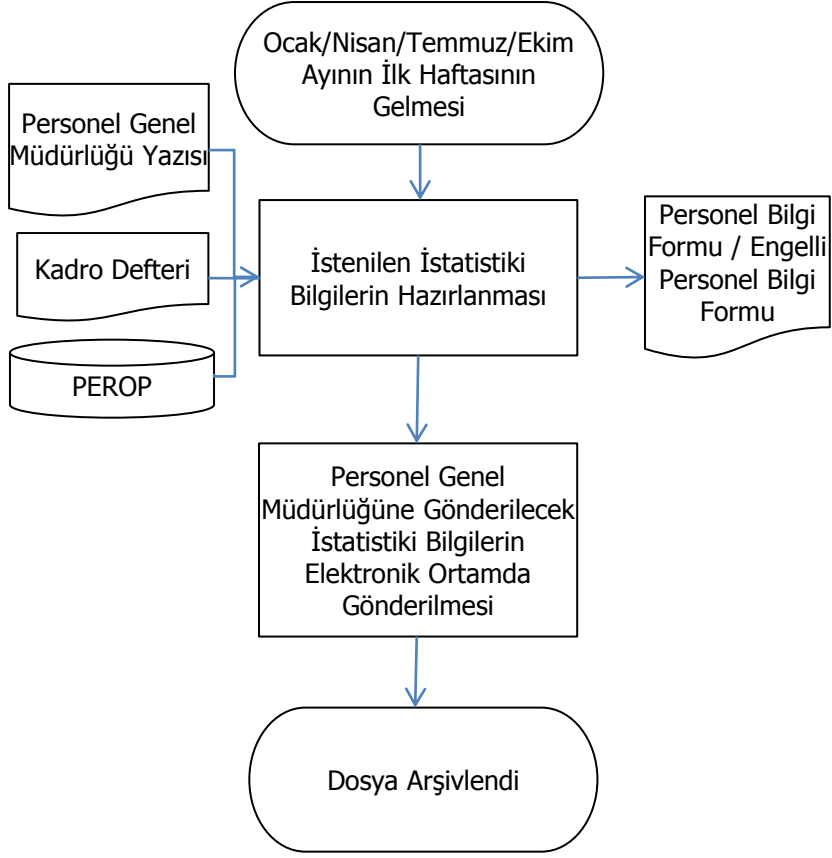

Hazırlayan:	Onaylayan:

BURDUR Defterdarlığı Personel Müdürlüğü Aday Memur Eğitim Süreci

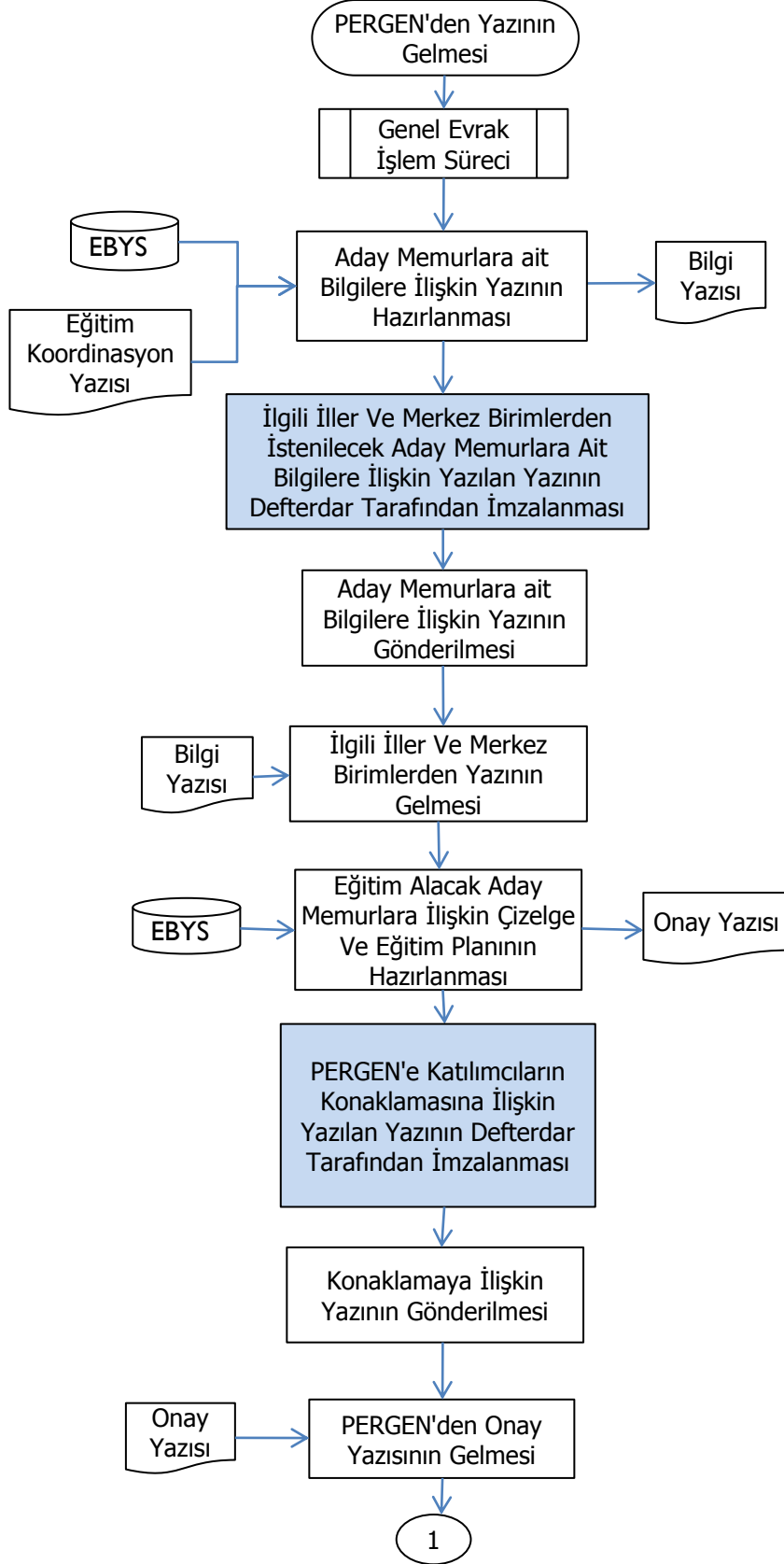

Hazırlayan:

Onaylayan:

--	--

BURDUR Defterdarlığı Personel Müdürlüğü Aday Memur Eğitim Süreci

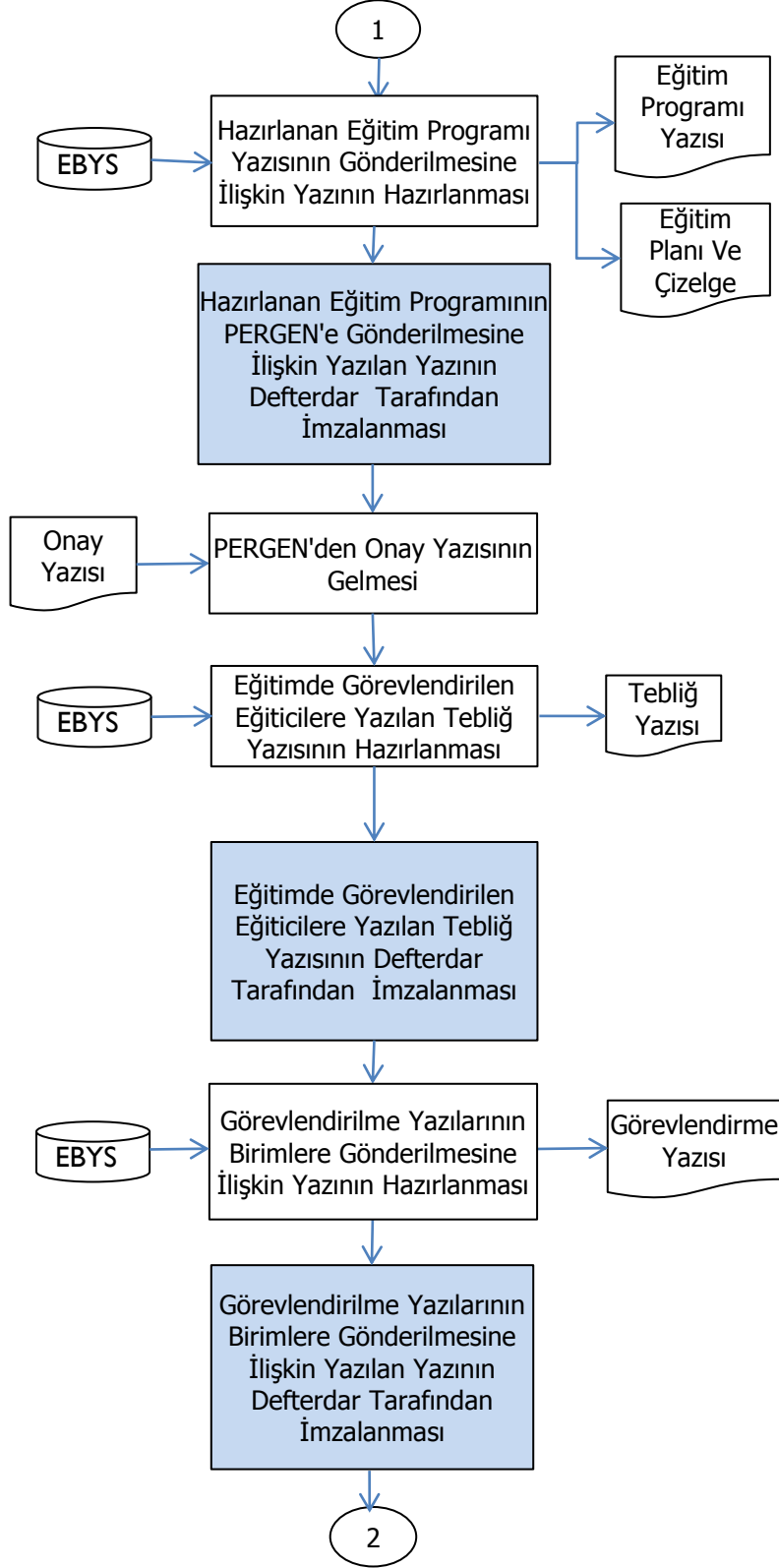

Hazırlayan:

Onaylayan:



BURDUR Defterdarlığı
Personel Müdürlüğü
Aday Memur Eğitim Süreci

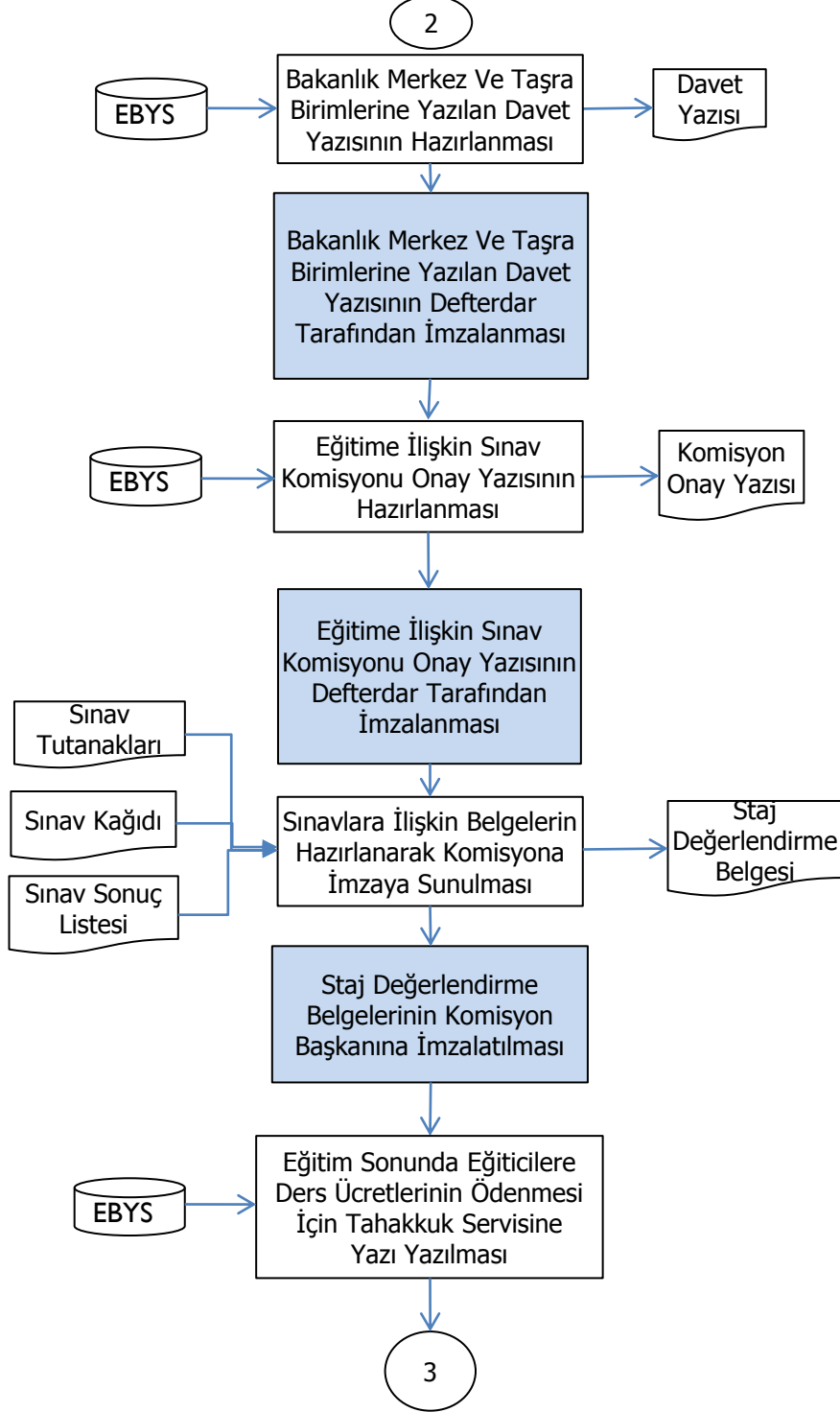

Hazırlayan:	Onaylayan:

BURDUR Defterdarlığı
Personel Müdürlüğü
Aday Memur Eğitim Süreci

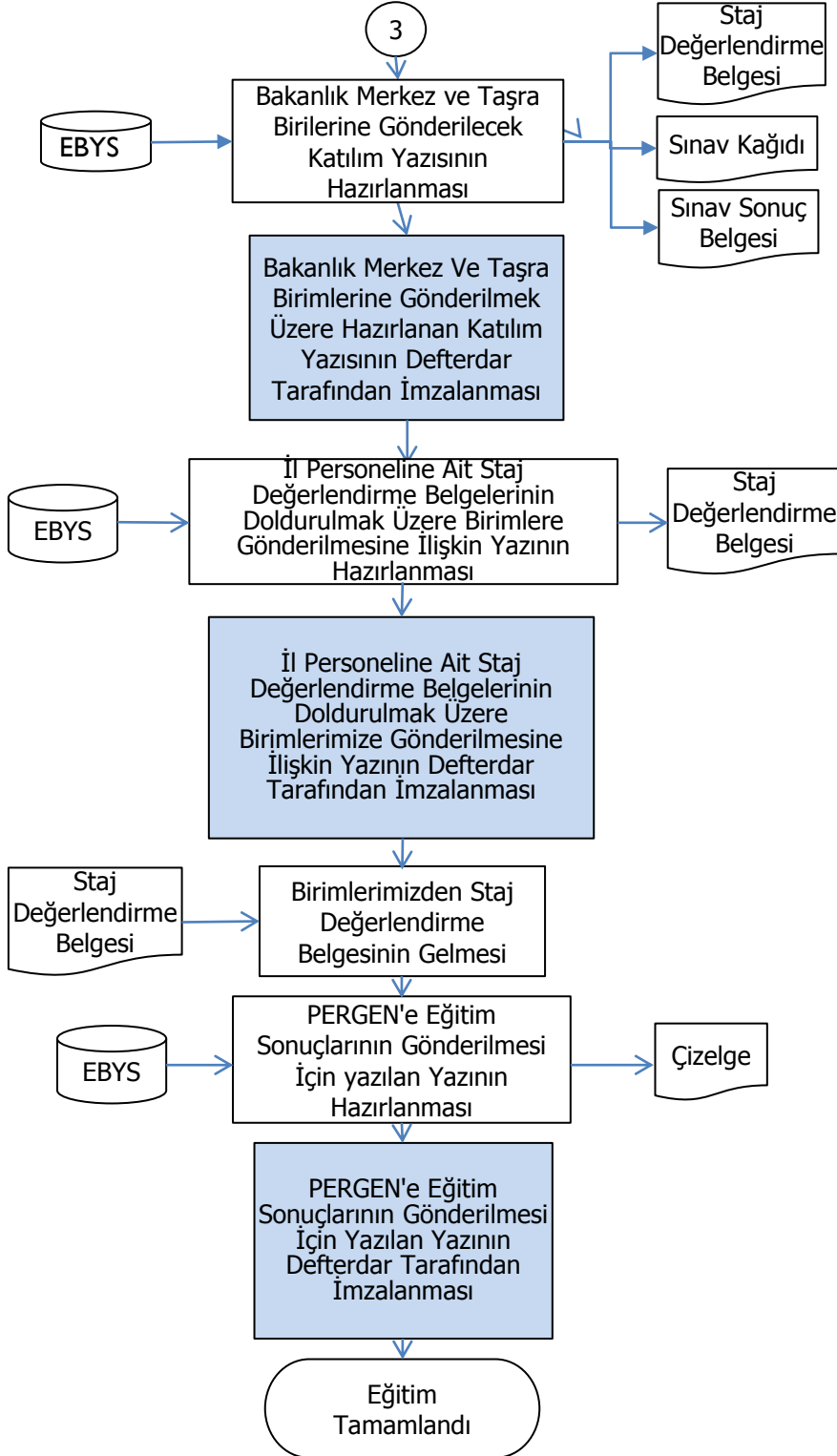

Hazırlayan:

Onaylayan:

--	--

BURDUR Defterdarlığı Personel Müdürlüğü Hizmet İçi Eğitim İşlem Süreci

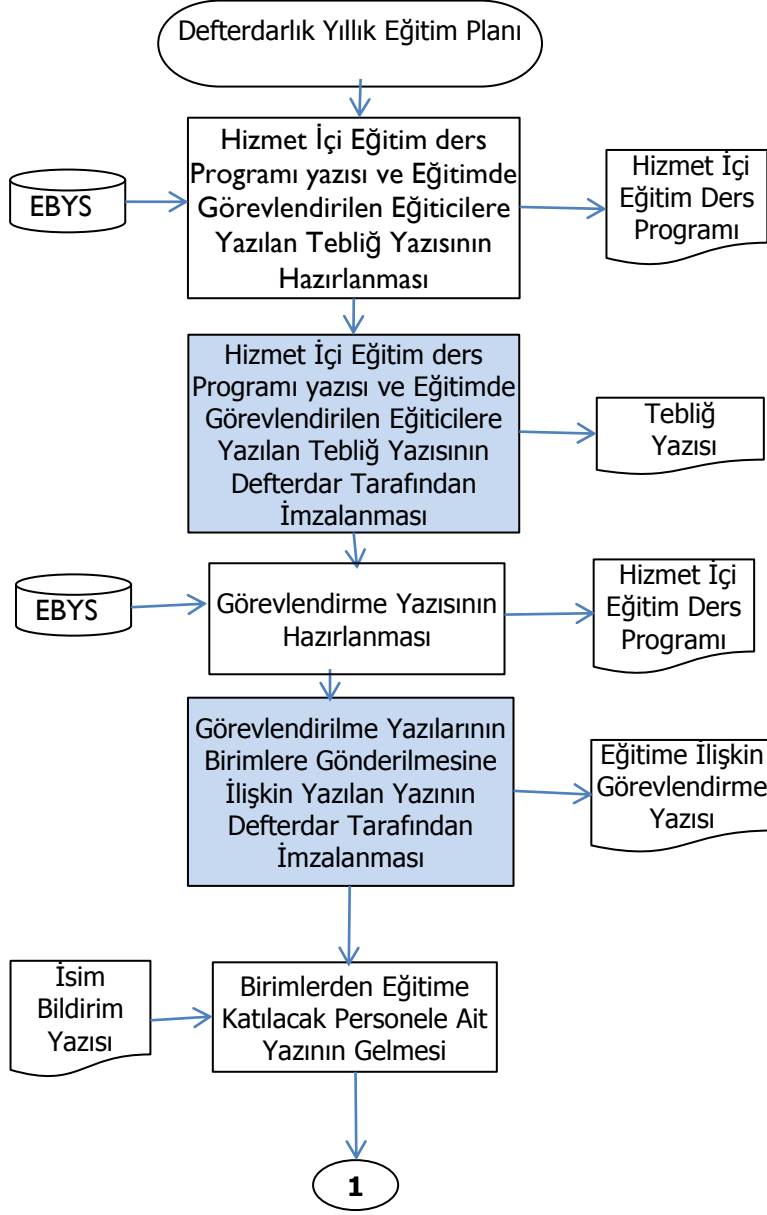

Hazırlayan:	Onaylayan:



BURDUR Defterdarlığı
Personel Müdürlüğü
Hizmet İçi Eğitim İşlem Süreci

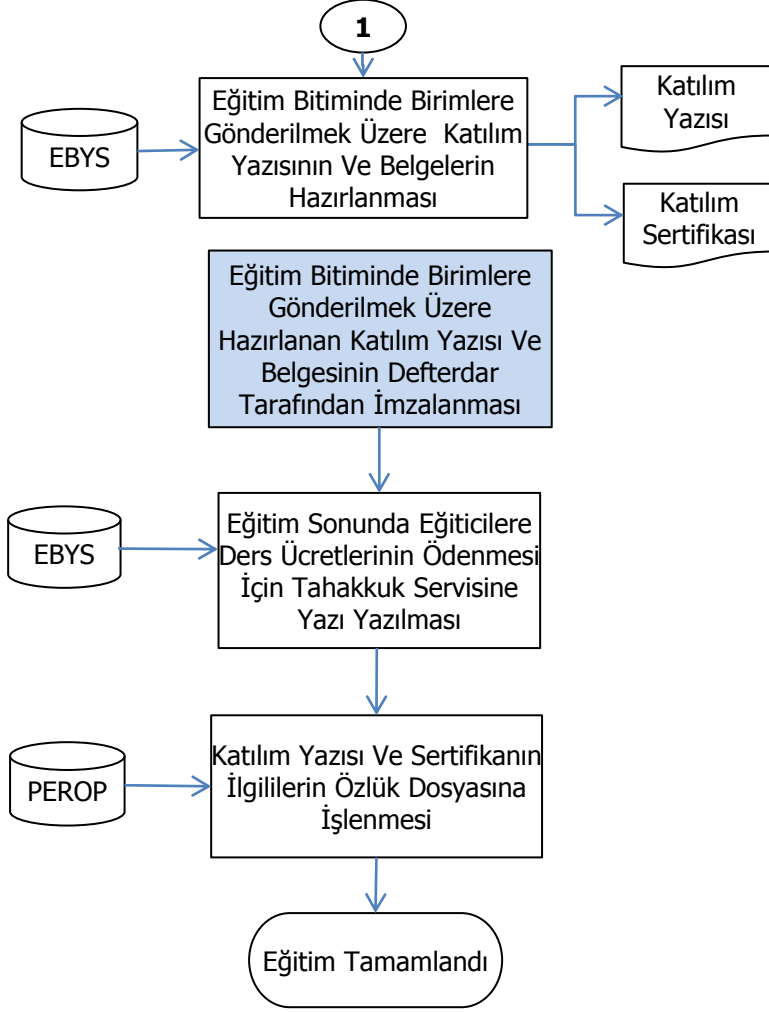

Hazırlayan:	Onaylayan:



BURDUR Defterdarlığı
Personel Müdürlüğü
Meslek Eğitim Kursu İşlem Süreci

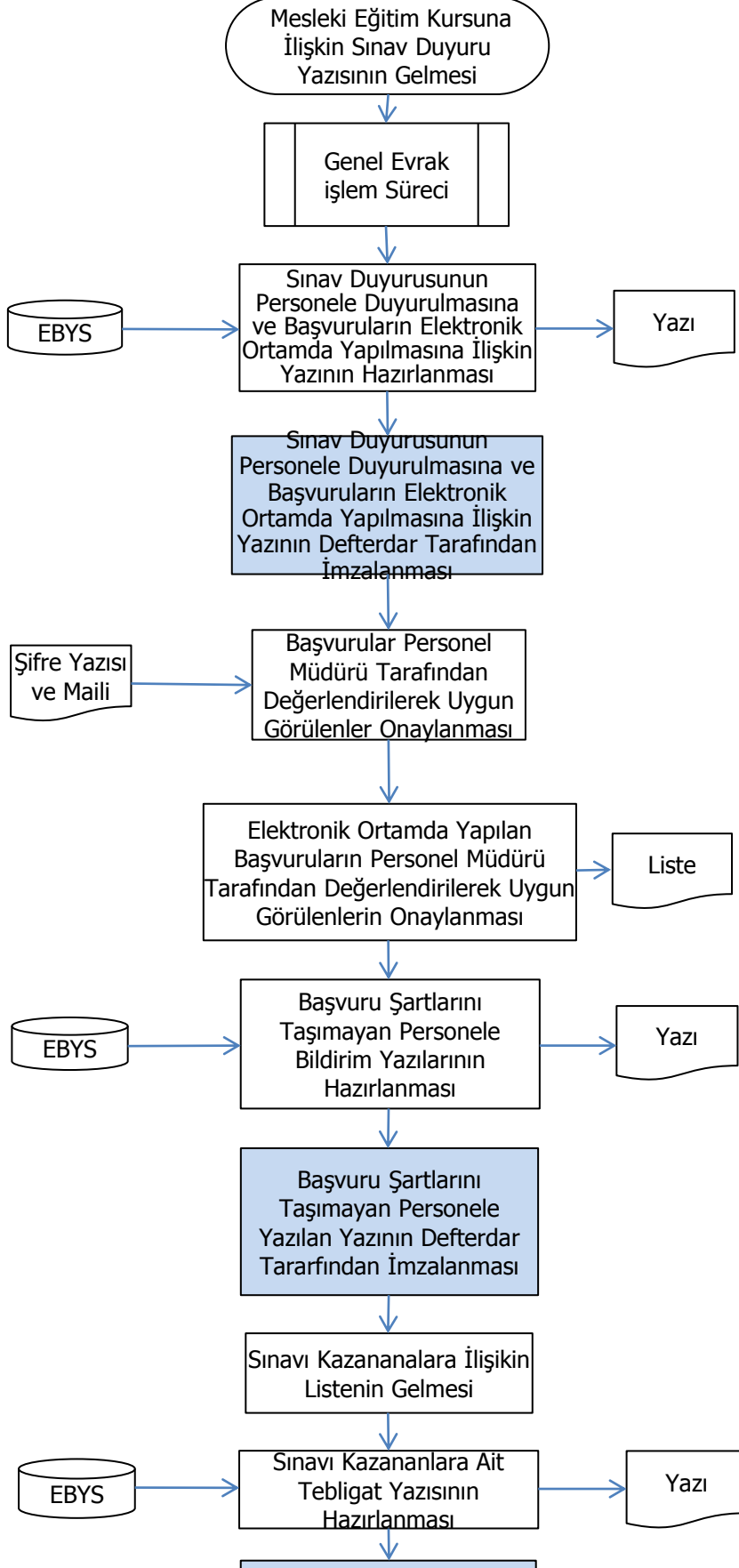

Sınavı Kazananlara Ait
Tebliğat Yazısının Defterdar
Tarafından İmzalanması



Dosyalarına
Kaldırıldı

Hazırlayan:	Onaylayan:

BURDUR Defterdarlığı Personel Müdürlüğü

Görevde Yükselme Ve Unvan Değişikliği İşlem Süreci

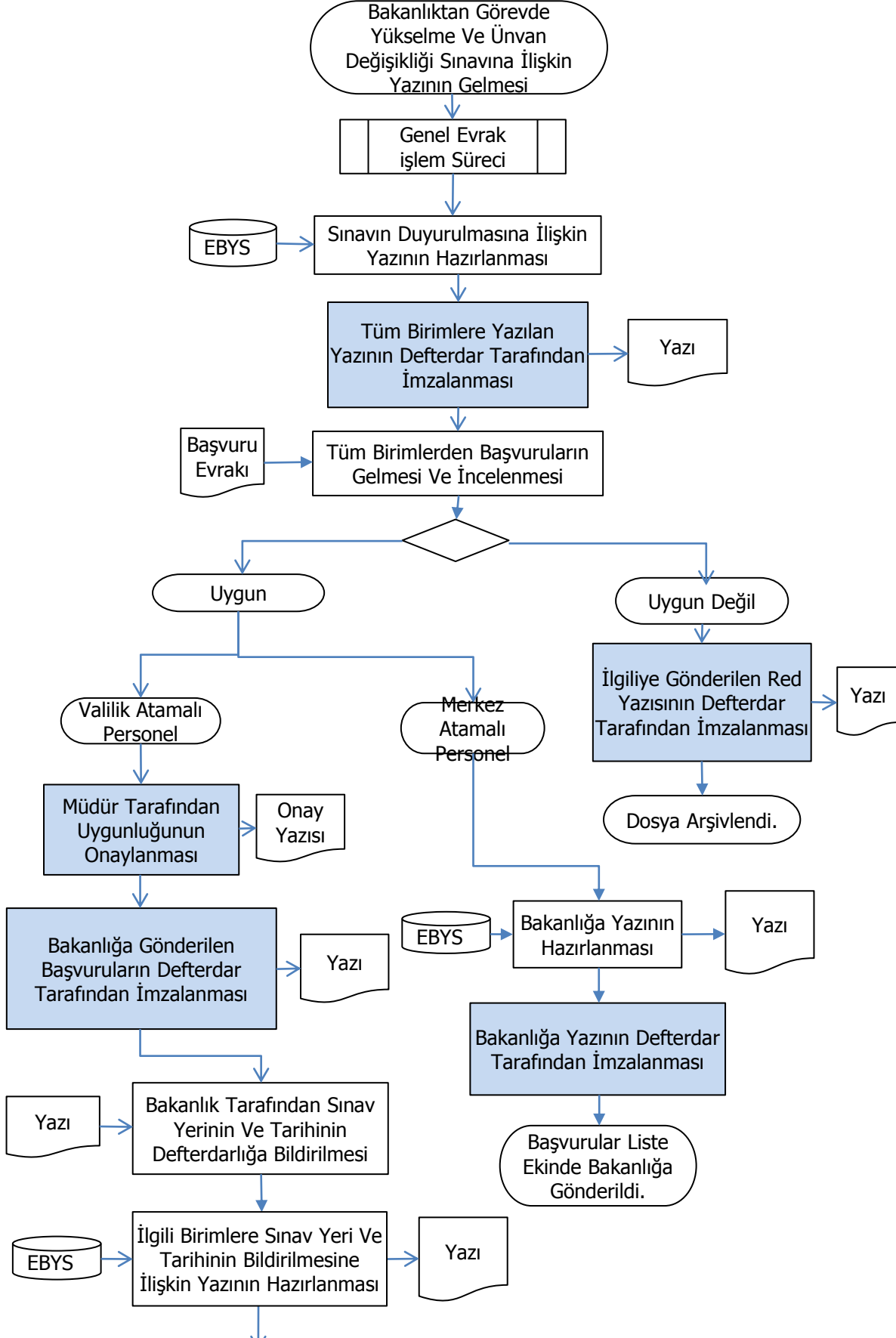

1

Hazırlayan:	Onaylayan:



BURDUR Defterdarlığı Personel Müdürlüğü

Görevde Yükselme Ve Unvan Değişikliği İşlem Süreci

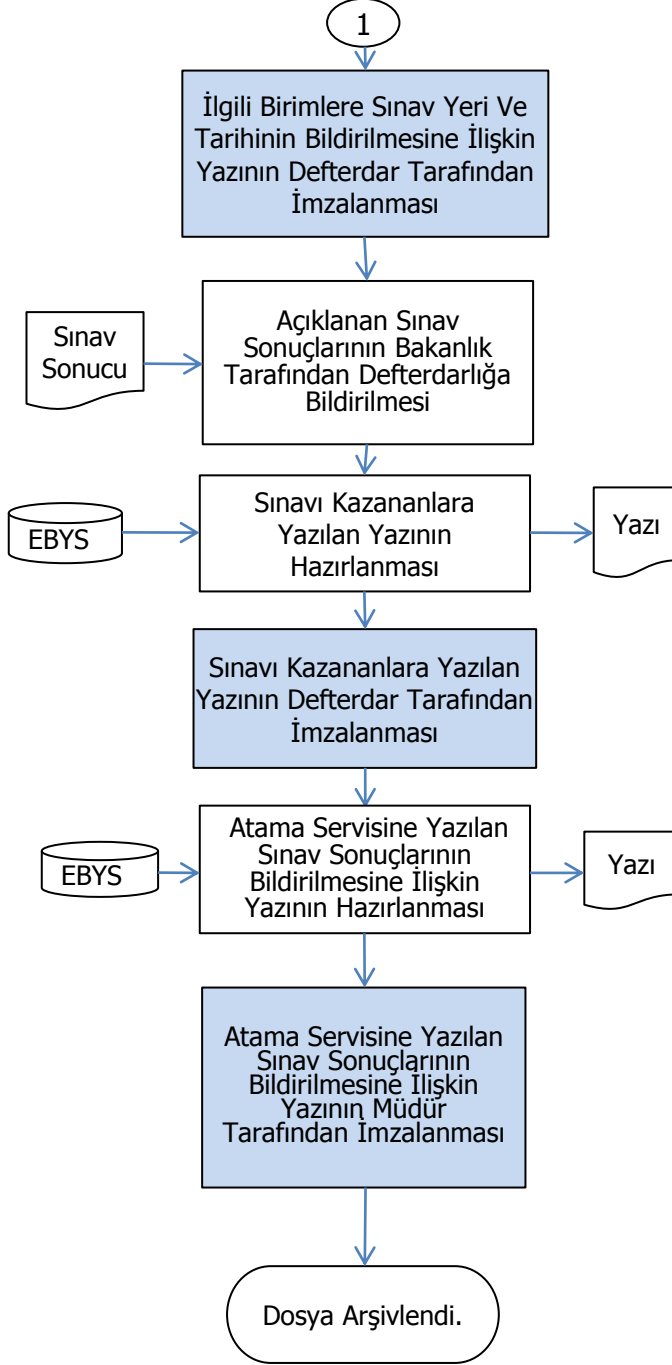

Hazırlayan:	Onaylayan:



BURDUR Defterdarlığı Personel Müdürlüğü

TODAİE Ve Diğer Kurum İle Kuruluşların Sınav Başvurusu İşlem Süreci

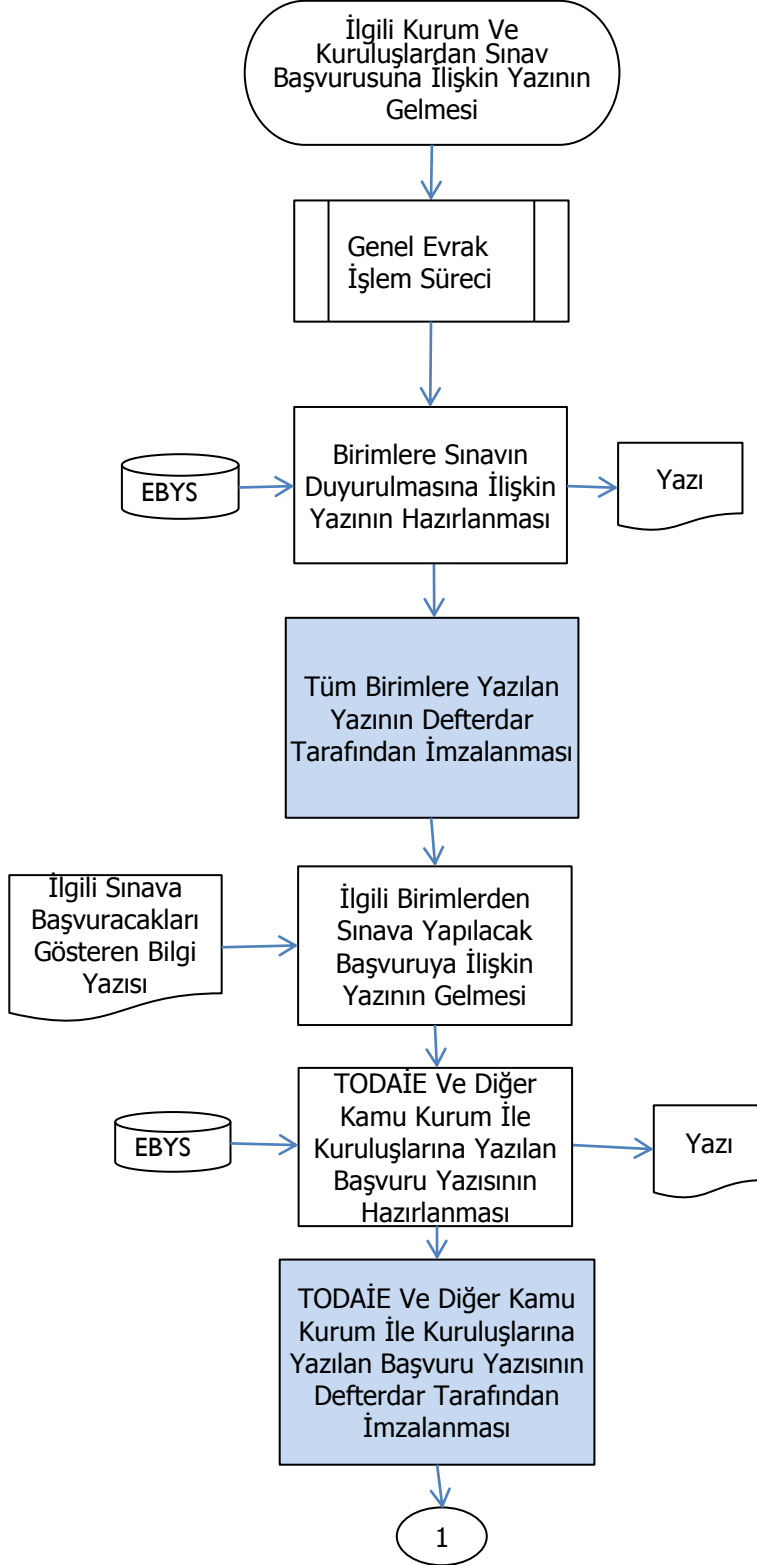

Hazırlayan:

Onaylayan:





BURDUR Defterdarlığı
Personel Müdürlüğü
TODAİE Ve Diğer Kurum İle Kuruluşların

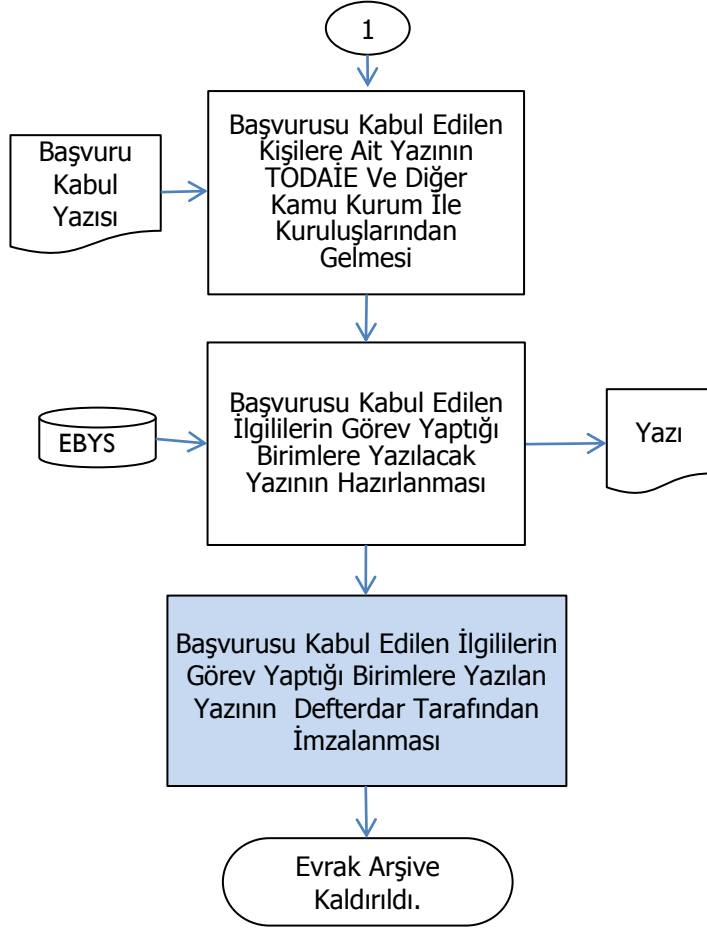

Hazırlayan:

Onaylayan:

--	--



BURDUR Defterdarlığı
Personel Müdürlüğü
Brifing Raporu Hazırlama İşlemleri Süreci

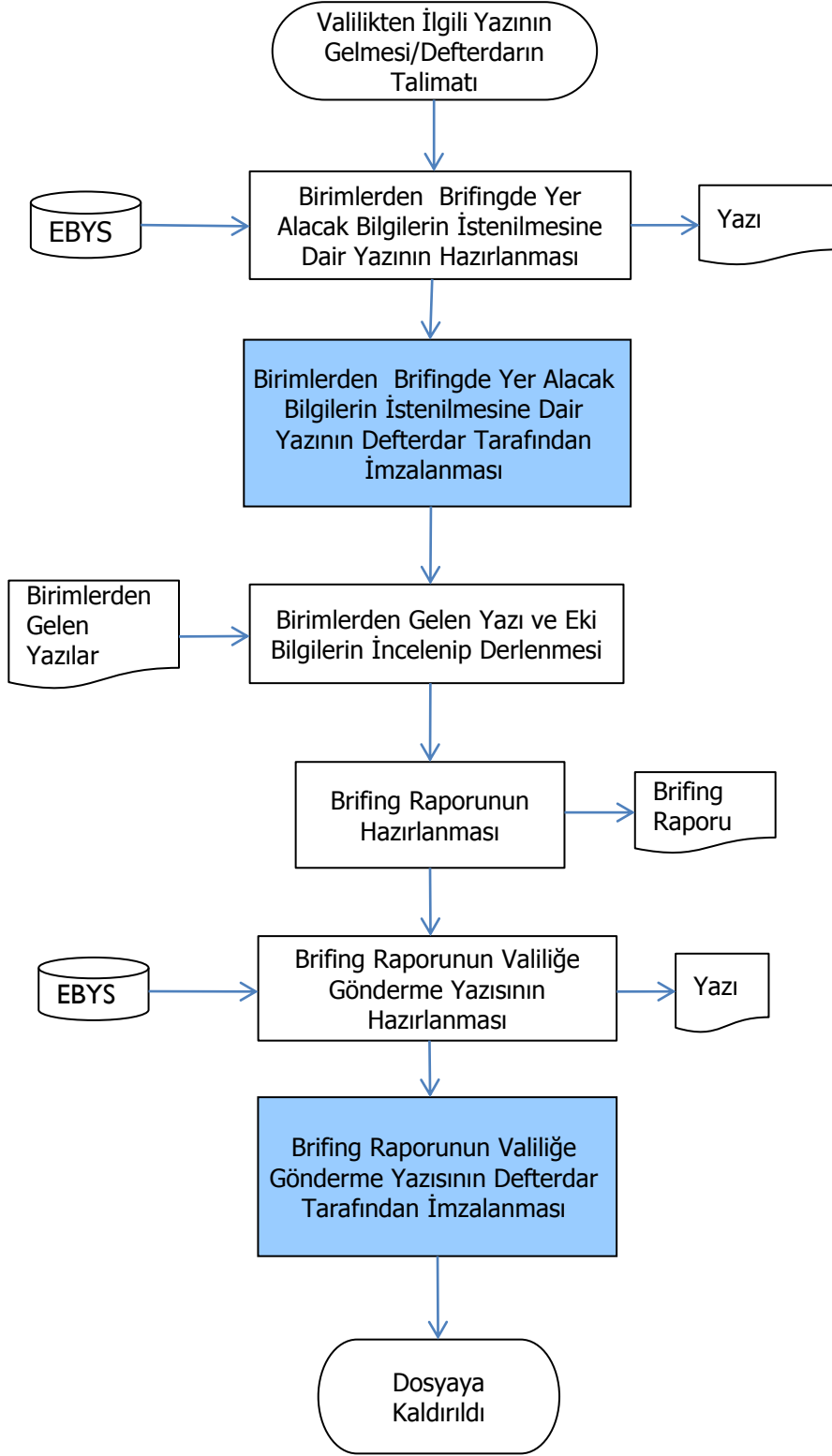

Hazırlayan:

Onaylayan:





BURDUR Defterdarlığı Personel Müdürlüğü

Arşiv İşlemlerinin Yürütülmesi Süreci

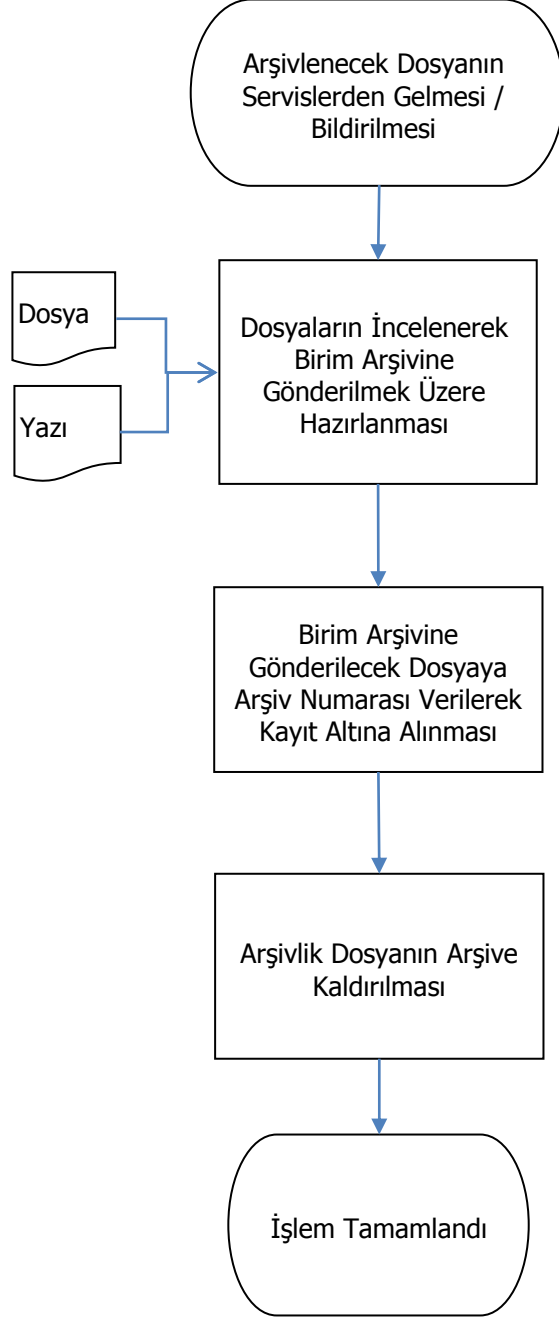

Hazırlayan:	Onaylayan:



BURDUR Defterdarlığı Personel Müdürlüğü

Bilgi Edinme Talebine İlişkin İşlem Süreci

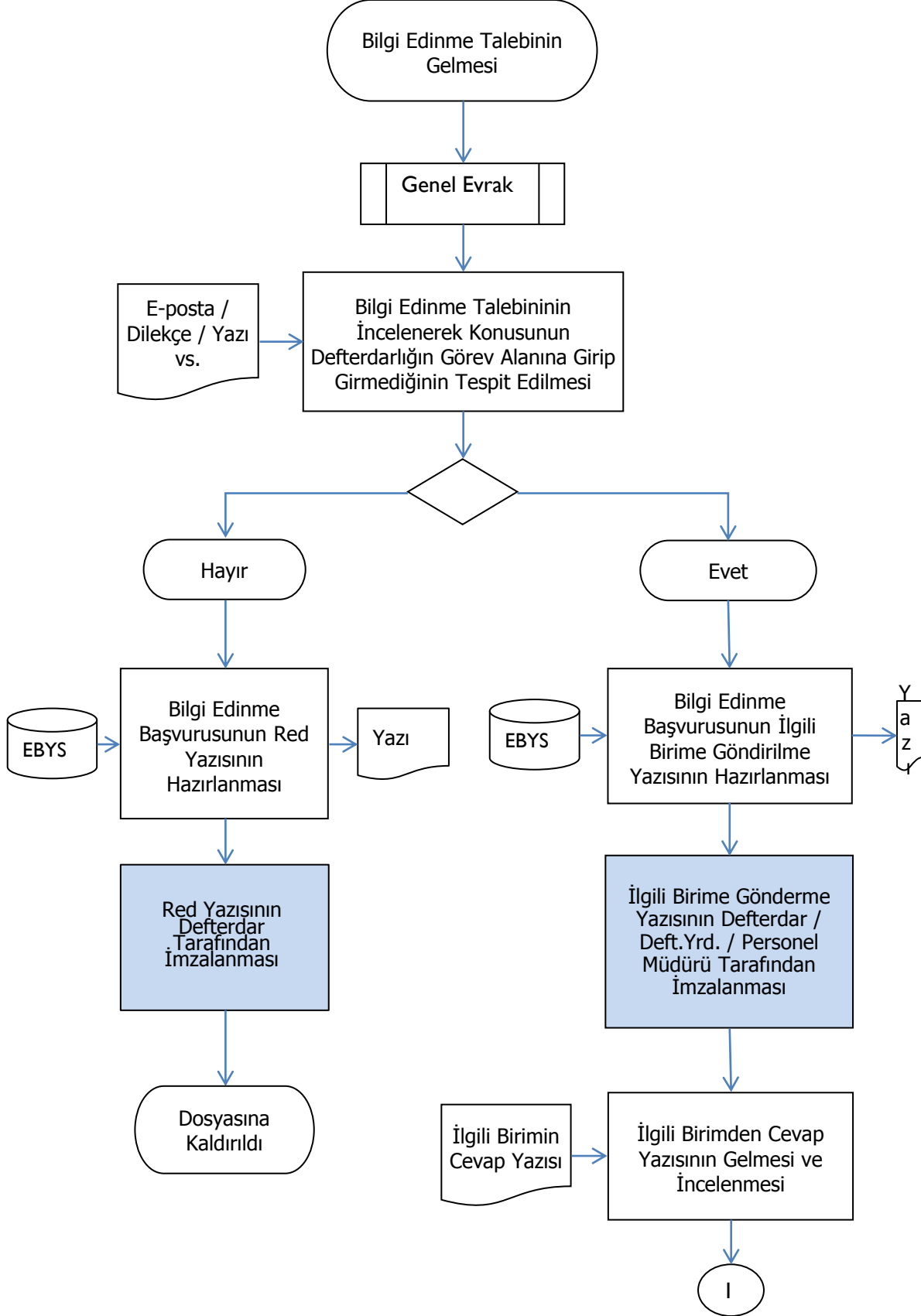

Hazırlayan:	Onaylayan:



BURDUR Defterdarlığı Personel Müdürlüğü

Bilgi Edinme Talebine İlişkin İşlem Süreci

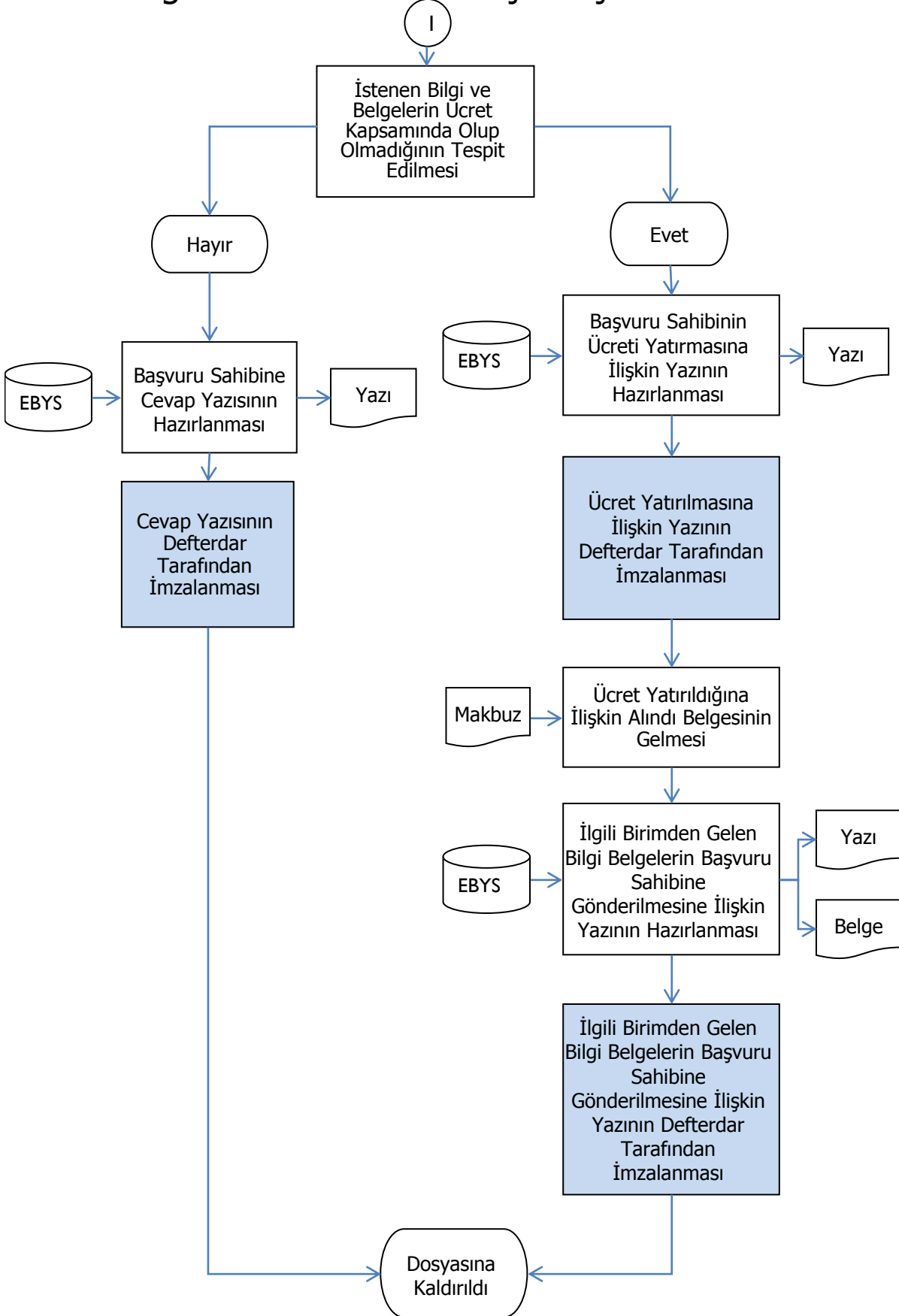

Hazırlayan:	Onaylayan:

BURDUR Defterdarlığı Personel Müdürlüğü Genel Evrak İşlem Süreci

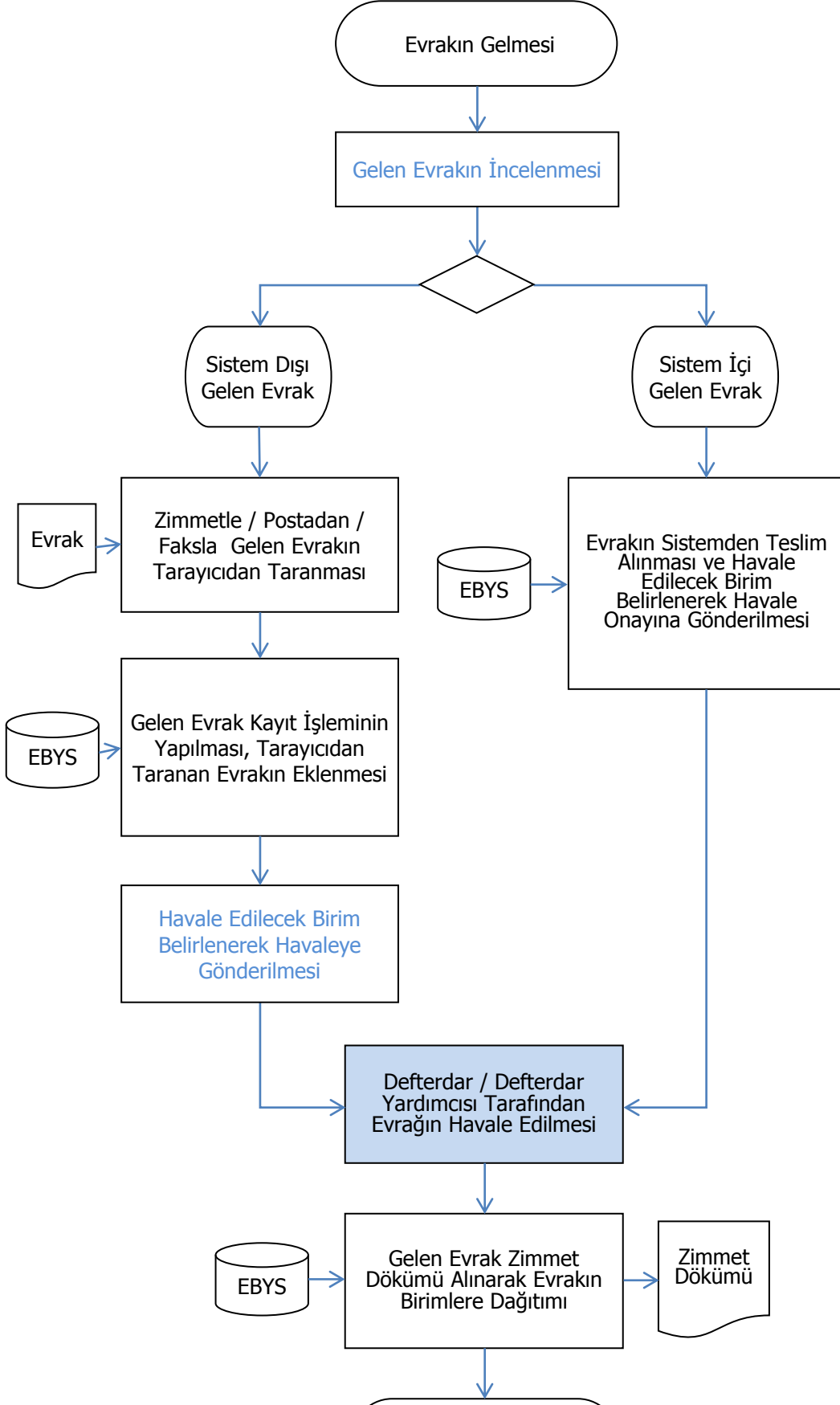

Zimmet Dökümünün
Dosyaya Kaldırılması

Hazırlayan:	Onaylayan:



BURDUR Defterdarlığı Personel Müdürlüğü

Kayıp/Çalıntı Kimlik İşlem Süreci

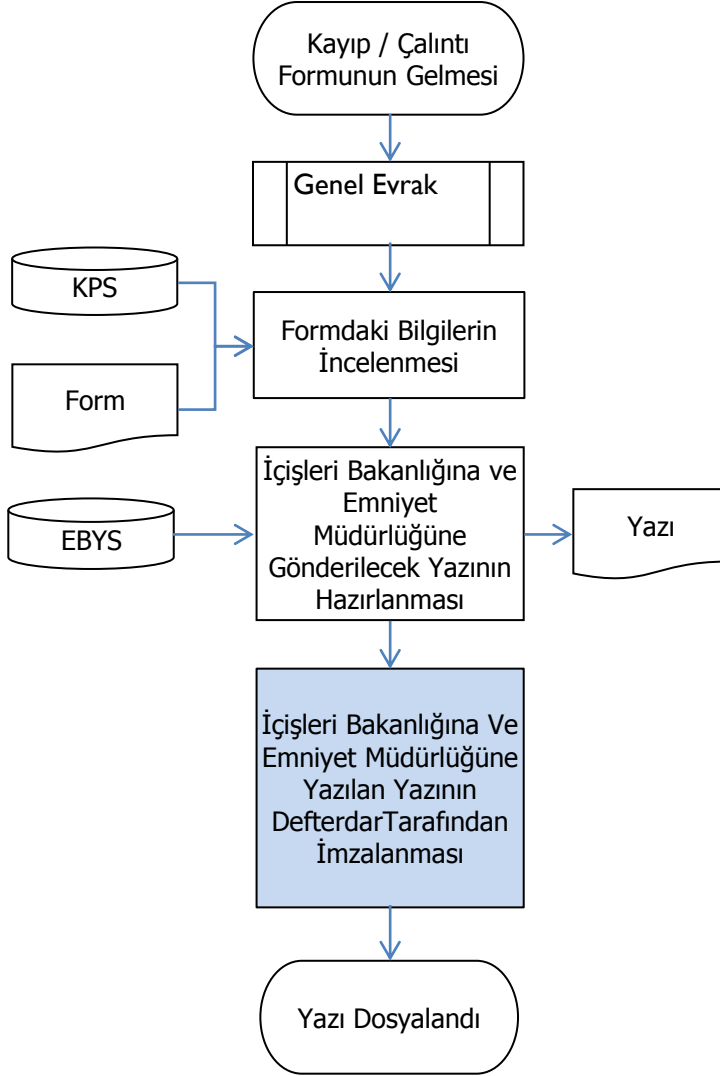

Hazırlayan:	Onaylayan:

BURDUR Defterdarlığı Personel Müdürlüğü Kimlik İşlemleri Süreci

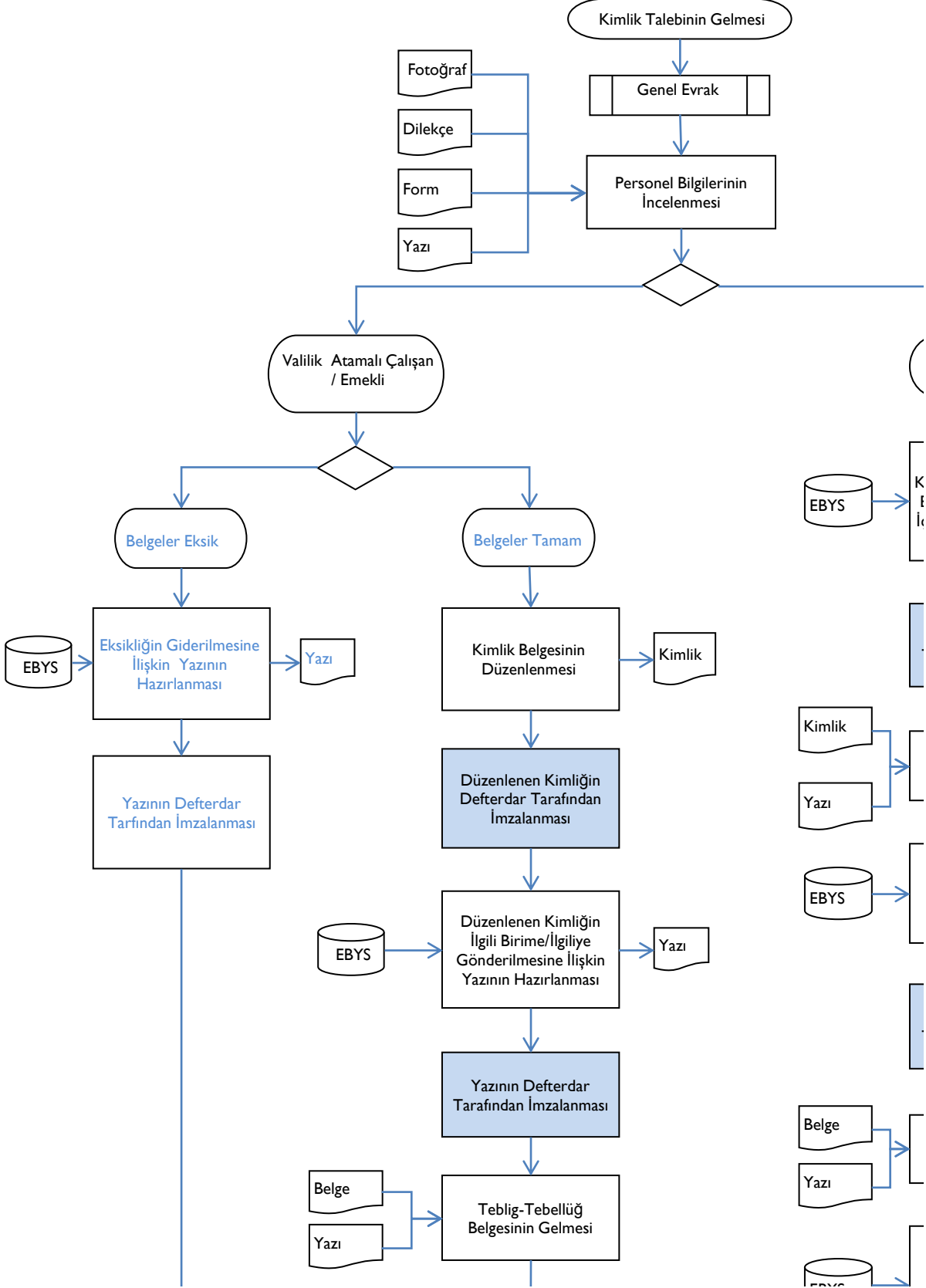

EBYS

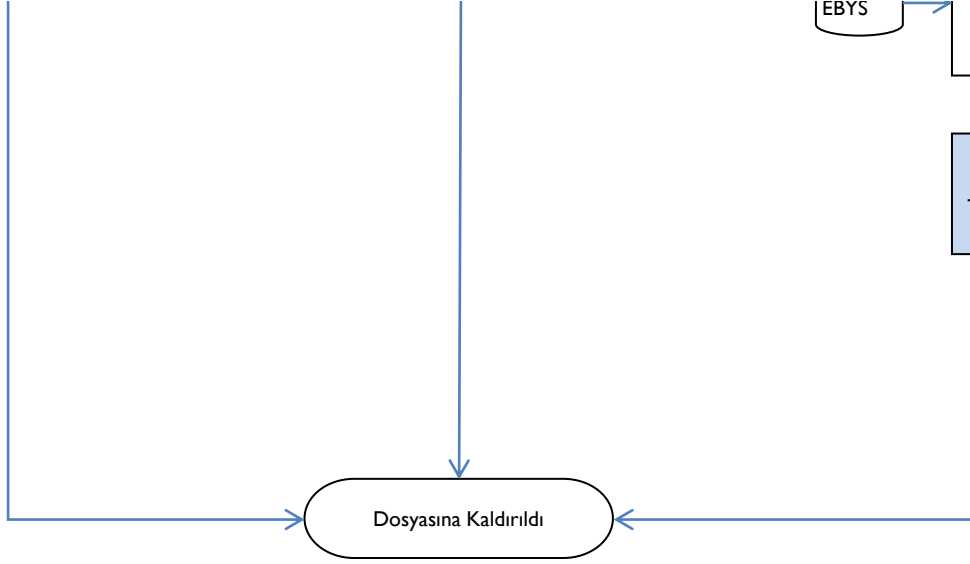

Hazırlayan:	Onaylayan:



Gönderilmesine İlişkin
Yazının Hazırlanması



Yazının Defterdar
Tarafından İmzalanması

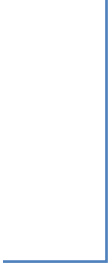

BURDUR Defterdarlığı Personel Müdürlüğü

Komisyon Üyesi Görevlendirme İşlem Süreci

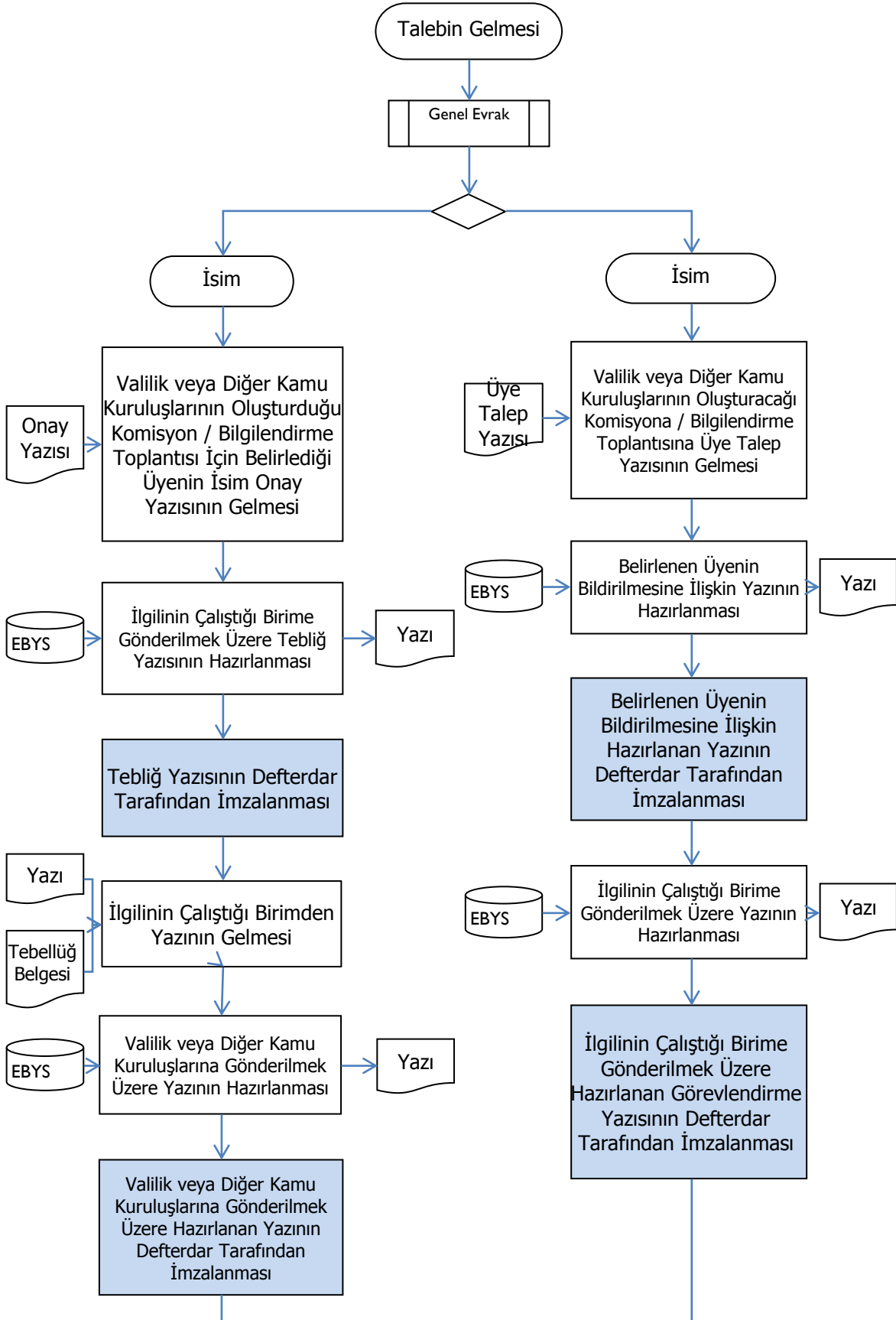



Hazırlayan:	Onaylayan:

BURDUR Defterdarlığı Personel Müdürlüğü

Pasaport Taleplerinin Karşlanması İşlem Süreci

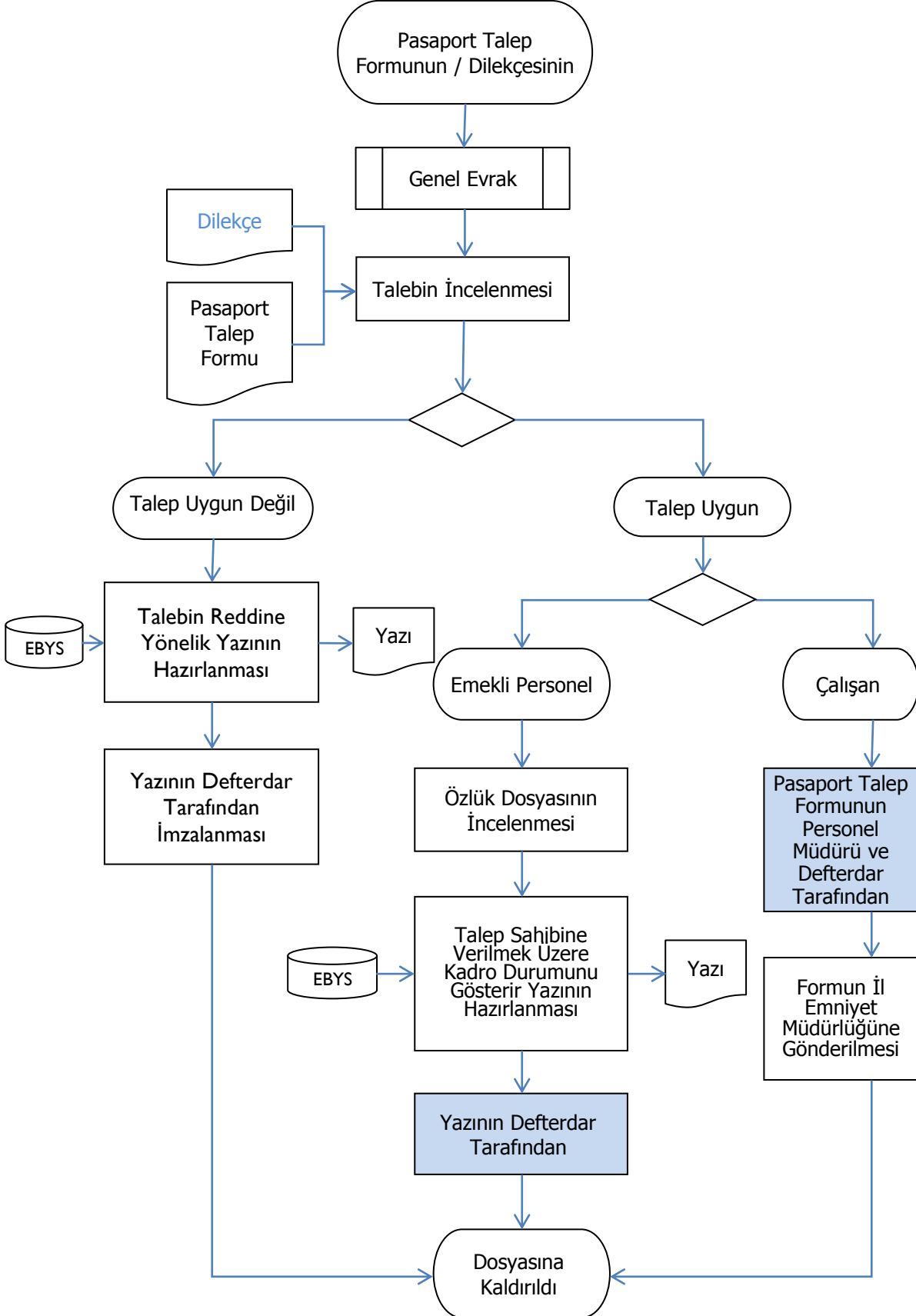

Hazırlayan:	Onaylayan:



BURDUR Defterdarlığı
Personel Müdürlüğü
Brifing Raporu Hazırlama İşlemleri Süreci

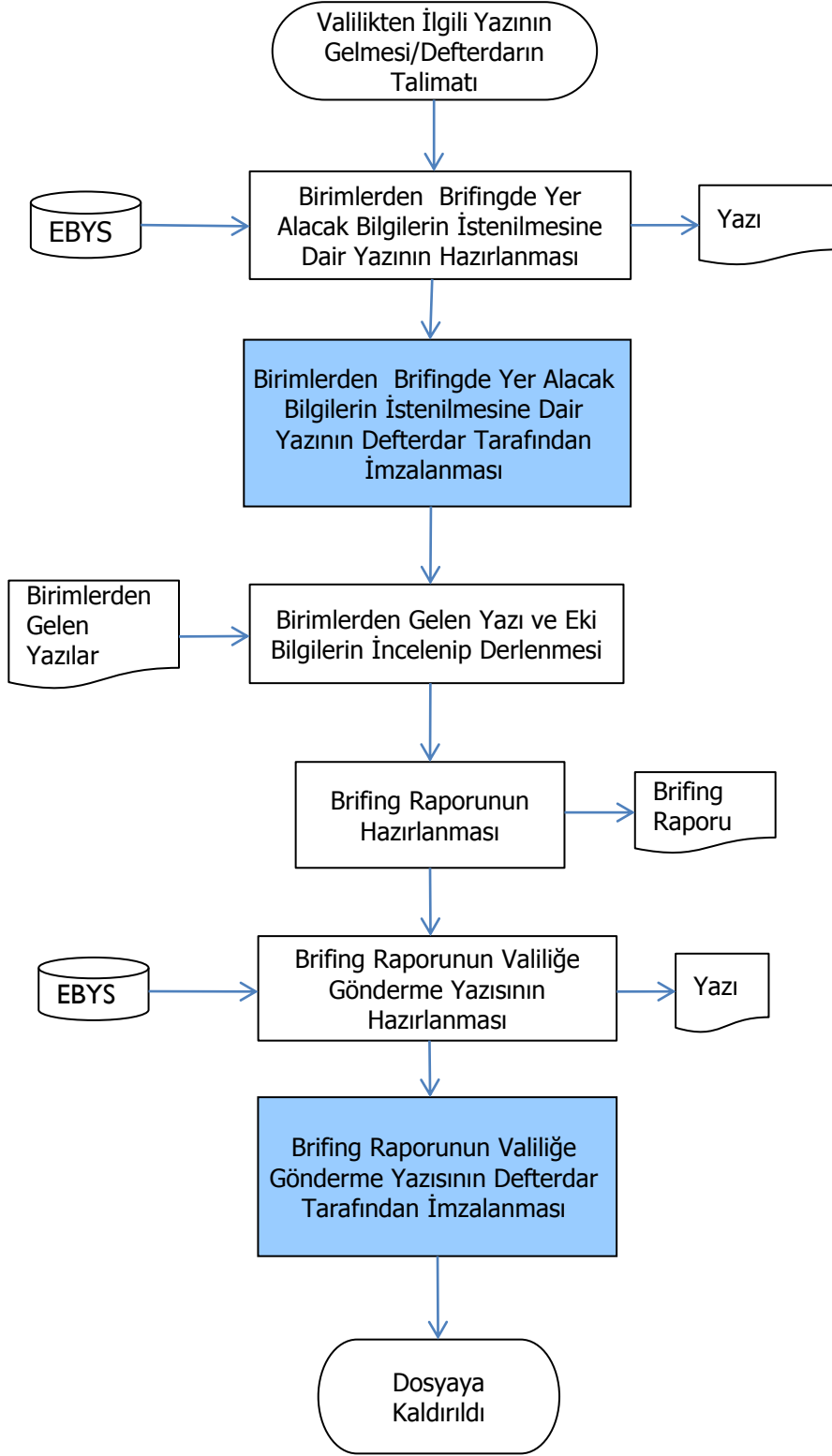

Hazırlayan:

Onaylayan:



BURDUR Defterdarlığı Personel Müdürlüğü Yolluk İşlem Süreci

